

Ward: Avonmore And Brook Green

Expiry Date:

Site Address:

Olympia Exhibition Centre Hammersmith Road London W14 8UX



© Crown Copyright. All Rights Reserved. London Borough Hammersmith and Fulham LA100019223 (2018).

For identification purposes only - do not scale.

Reg. No:

2018/03100/FUL

Date valid:

11.10.2018

Committee Date:

30.01.2019

Case Officer:

Peter Wilson

Conservation Area:

Olympia And Avonmore
Conservation Area - Number 23

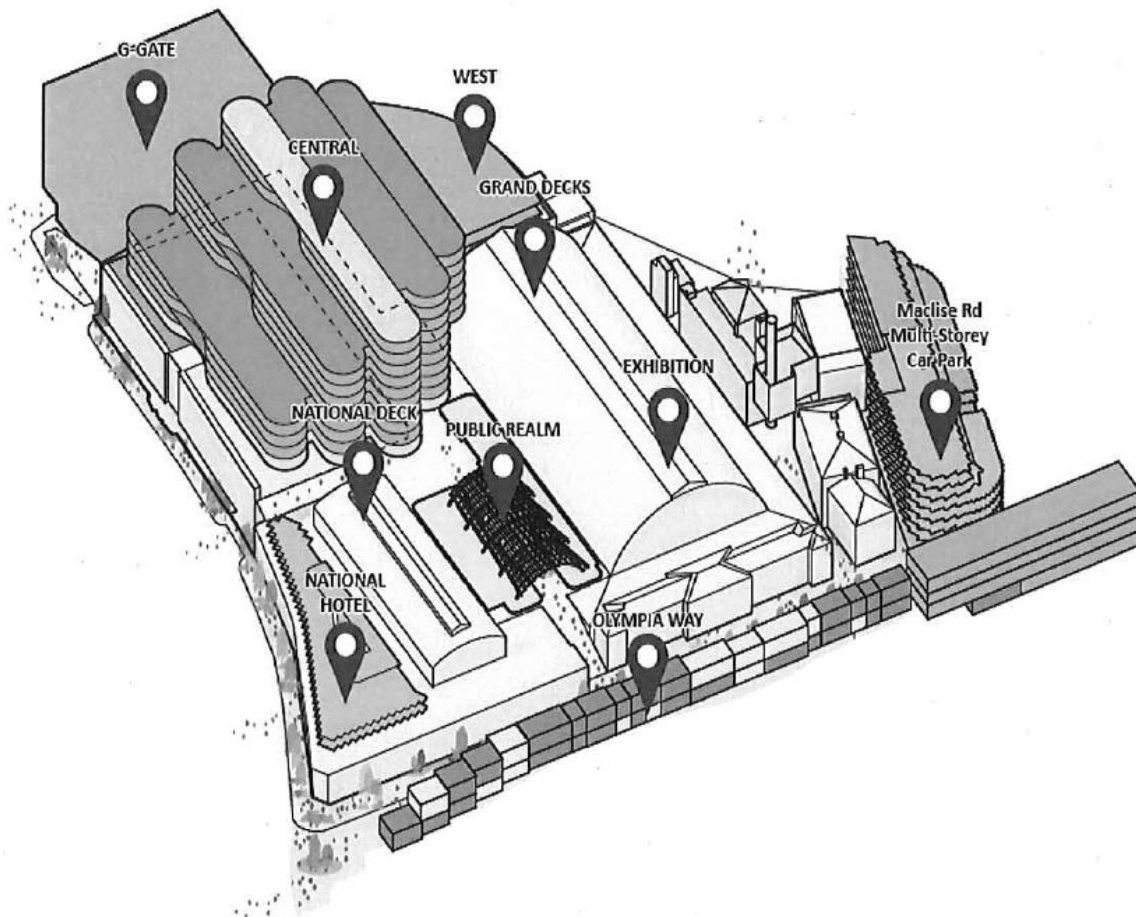

Image: Proposed development

Applicant:

Olympus Property Holding Limited

Description:

Redevelopment of Olympia comprising: a) Central Hall - demolition with retention of listed façade to Hammersmith Road, erection of new ground plus 12 storey building for (B1) office, (D1) exhibition, flexible (A1-A4) retail/financial and professional services /restaurant/bar, and flexible (B1/D1) office/conference uses; new site-wide logistics centre, car/cycle parking and plant within two new basement levels; b) G-gate site - erection of ground plus 9 upper storeys building with two levels of basement for use as a theatre, (D1) exhibition and flexible (A3/A4) restaurant/bar use at ground/level 2 and roof level; c) National Hall - internal and external alterations comprising three storey roof-level extension for use as (C1) hotel, part use of National Hall for (A1-A4/C1) hotel and ancillary use, two levels of internal decks for use as (D1) exhibition space and flexible (D1) exhibition/(A3/A4) restaurant/bar use, alterations to existing basement and associated internal and external works; d) West Hall - alterations and extension to provide two additional storeys for use as (D2) live music and performance space; e) Maclise Road Multi Storey Car Park - partial demolition, alterations and extension for use as (C1) hotel, (D2) cinema, and flexible (B1/D1) co-working/conference use; f) Grand and National Halls - demolition of existing accommodation and circulation spaces between halls and construction of new Level 2 public realm deck with glazed canopy comprising flexible use (A1-A4) retail/restaurant/bar/financial and professional services; g) Pillar Hall - Internal and external alterations for use of building for (A3/A4)

restaurant/bar, ancillary live music; h) Grand Hall - internal and external alterations including creation of two levels of internal decks for use as (D1) exhibition space and flexible (D1), (A3/A4) exhibition/restaurant/bar use; i) Plant and energy centres; j) Pedestrian/vehicle/cycle/highway works; k) Public realm, landscaping and associated works.

Drg. Nos: See Condition 2

Application type:

Full Detailed Planning Application

REPORT CONTENTS

RECOMMENDATIONS

CONDITIONS

REASONS FOR APPROVAL

1.0 BACKGROUND

- 1.2 Mayoral Referral**
- 1.6 Site and Designations Context**
- 1.25 Planning History**

2.0 PROPOSAL

- 2.12 Environmental Statement**

3.0 PUBLICITY AND CONSULTATIONS

4.0 PLANNING POLICY FRAMEWORK

5.0 PLANNING CONSIDERATIONS

- 5.1 Principle of Development and Land Use**
- 5.2 Socio Economics and Community Effects**
- 5.3 Design and Heritage**
- 5.4 Daylight and Sunlight**
- 5.5 Highways**
- 5.6 Sustainability and Energy**
- 5.7 Flood Risk and Drainage**
- 5.8 Ground Contamination**
- 5.9 Air Quality**
- 5.10 Noise and Vibration**
- 5.11 Lighting**
- 5.12 Wind and Microclimate**
- 5.13 Ecology**
- 5.14 Security**
- 5.15 Accessibility**

6.0 SECTION 106 HEADS OF TERMS AND CIL

7.0 CONCLUSIONS

Appendix 1: Consultation Comments

Appendix 2: Neighbour Comments

Officer Recommendation:

1) Subject to there being no contrary direction from the Mayor for London that the Committee resolve that the Strategic Director for Growth and Place be authorised to determine the application and grant permission upon the completion of a satisfactory legal agreement and subject to the conditions listed below;

2) To authorise the Strategic Director for Growth and Place, in consultation with the Director of Law and the Chair of the Planning and Development Control Committee, to make any minor changes to the proposed conditions or heads of terms of the legal agreement. Any such changes shall be within their discretion.

CONDITIONS

In line with the Town and Country Planning Act 1990 and the Town and Country Planning (Pre-commencement Conditions) Regulations 2018, officers have consulted the applicant on the pre-commencement conditions included in the agenda and the applicant has raised no objections.

Definitions

“**Council**” means the London Borough of Hammersmith and Fulham.

“**Development**” means the statutory definition of ‘development’ which is set out in Section 55 of the Town and Country Planning Act 1990 (as amended).

“**The Development**” means “Redevelopment of Olympia comprising: a) Central Hall - demolition with retention of listed façade to Hammersmith Road, erection of new ground plus 12 storey building for (B1) office, (D1) exhibition, flexible (A1-A4) retail/financial and professional services /restaurant/bar, and flexible (B1/D1) office/conference uses; new site-wide logistics centre, car/cycle parking and plant within two new basement levels; b) G-Gate site - erection of ground plus 9 upper storeys building with two levels of basement for use as a theatre, (D1) exhibition and flexible (A3/A4) restaurant/bar use at ground/level 2 and roof level; c) National Hall - internal and external alterations comprising three storey roof-level extension for use as (C1) hotel, part use of National Hall for (A1-A4/C1) hotel and ancillary use, two levels of internal decks for use as (D1) exhibition space and flexible (D1) exhibition/(A3/A4) restaurant/bar use, alterations to existing basement and associated internal and external works; d) West Hall - alterations and extension to provide two additional storeys for use as (D2) live music and performance space; e) Maclise Road Multi Storey Car Park - partial demolition, alterations and extension for use as (C1) hotel, (D2) cinema, and flexible (B1/D1) co-working/conference use; f) Grand and National Halls - demolition of existing accommodation and circulation spaces between halls and construction of new Level 2 public realm deck with glazed canopy comprising flexible use (A1-A4) retail/restaurant/bar/financial and professional services; g) Pillar Hall - Internal and external alterations for use of building for (A3/A4) restaurant/bar, ancillary live music; h) Grand Hall - internal and external alterations including creation of two levels of internal decks for use as (D1) exhibition space and flexible (D1), (A3/A4) exhibition/restaurant/bar use; i) Plant and energy centres; j) Pedestrian/vehicle/cycle/highway works; k) Public realm, landscaping and associated works”.

“**Level 2**” means the area between Grand Hall and National Hall, which is proposed to become an elevated public access route connecting the various plots of Olympia from Olympia Way to Hammersmith Road.

“**Grand Hall**” means the Grade II* exhibition hall fronting Olympia Way.

“**National Hall**” means the Grade II exhibition hall located on the corner of Olympia Way and Hammersmith Road.

“**G-Gate**” means the area on the corner of Hammersmith Road and Lyons Walk, which is currently a servicing yard.

“**West Hall**” means the exhibition hall attached to the Grand and Central Hall, located on Blythe Road.

“**Pillar Hall**” means the Grade II* listed hall located on Olympia Way.

“**Central**” means the Olympia Central building which is Grade II listed, fronting Hammersmith Road.

“**MSCP**” means the Maclise Road Multi-storey Car Park which is Grade II listed and located on the corner of Maclise Road and Olympia Way.

“**L-Yard**” means the area behind Pillar Hall that fronts onto Beaconsfield Terrace which consists of a series of ancillary buildings accommodating plant rooms and mechanical equipment, along with some open land used for logistics and servicing.

“**Phases**” means the Phases of work for the Development as defined below:

“**Phase 1**” means the works including:

Sub-Phase 1a Infrastructure and temporary works required for the first stage of the Development which comprise:

- Substructure works and concrete slab within G-Gate; and
- Internal piling and foundation works within Grand Hall, National Hall, and West Hall.

Sub Phase 1b:

- Modifications to West Hall.

Sub Phase 1c works including:

- Construction of new switch rooms, Energy Centre structure, temporary and permanent MEP plant for business continuity, new Energy Centre flue, new external Goods lift and new Gas Meter room.

“**Phase 2**” means the works, including:

Sub-Phase 2a:

- Construction of a new Music venue above existing West Hall exhibition areas;
- Demolition of the existing Central building, while retaining the listed Art Deco façade on Hammersmith Road;
- Construction of a protected logistics area within the Ground floor and basement;
- Construction of a new build exhibition halls and office behind the Central façade;
- Installation of New Energy Centre plant and equipment in L Yard.

Sub-Phase 2b:

- Provision of new accesses and public realm between Grand Hall, National Hall and Central.

Sub-Phase 2c

- Internal refurbishment of Pillar Hall.

“**Phase 3**” means the works including;

Sub-Phase 3a:

- Piling and construction of a logistics area within the ground floor and basement within G Gate as well as a new build theatre above;

Sub-Phase 3b:

- Partial demolition of the existing MSCP, with demolition of sections of the southern part of the building, modifications to the existing structure and construction of new floors above for new Hotel and Co-working offices.

“Phase 4” means the works including:

Sub-Phase 4a:

- Construction within National Hall and extension above to provide a hotel;

Sub-Phase 4b:

- Construction of internal decks within Grand Hall and National Hall.

“Enabling Works” means:

- Site clearance (excluding demolition works)
- Preparatory works & MEP/utility relocations (Existing Utility and Mechanical, Electrical and Public Health Building Services (MEP) Diversions), particularly L-Yard, installation of additional power to the site
- Site investigations and surveys
- Fixtures and fitting strip out (excluding listed buildings)
- Temporary access/highway works
- Temporary welfare and office accommodation
- Hoardings

“Commencement” means in respect of the Development or individual Stages (as relevant) the initiation of development as defined in Section 56(4) of the Town and Country Planning Act 1990 (as amended) including “Commence” which shall be construed accordingly.

“Practical Completion” means completion save in minor respects so that the Development can be used and operated in the manner permitted by the Planning Permission.

“Olympia Way Outline Application” means the outline planning application (ref: 2018/03102/OUT) for access, layout, landscape, appearance, and scale for Olympia Way, including the demolition of the existing building adjacent to the station entrance, construction of buildings up to 4 storeys in height for flexible uses, public realm, and associated landscaping.

“Listed Building Consent” means the listed building consent application that is related to this application, that covers works to listed buildings on site, including Grand Hall, National Hall, Pillar Hall, Olympia Central and the Maclise Road Multi-storey Car Park.

1. Time Limit

The Development shall be begun as follows:

- (a) Enabling Works and Phase 1 shall be begun not later than 3 years beginning with the date of this full planning permission;
- (b) Phase 2 and Phase 3 shall be begun not later than 5 years beginning with the date of this full planning permission;
- (c) Phase 4 shall be begun not later than 7 years beginning with the date of this full planning permission; and

Reason: Condition required to be imposed by Section 92(2)(a) of the Town and Country Planning Act 1990. Extended time periods for which the planning permission can be implemented is given considering exceptional circumstances relevant to the Demolition, Ground and Enabling Works, Operation and the extent of the development.

2. Approved Drawings

The Development shall be carried out and completed in accordance with the following approved drawings:

(D-80) Demolition Area Schedule

1709-SPP-SC-A-ZZ-D-80-XX-01-01 Masterplan - Demolition Area Schedule **P01**

(P-00) Site Plan

1709-SPP-DR-A-ZZ-P-20-0S-01-01 Masterplan - Proposed Site Plan **P01**

(P-20) Proposed Plans

1709-SPP-DR-A-ZZ-P-20-B1-01-01 Masterplan - Proposed Level B1 Floor Plan **P01**

1709-SPP-DR-A-ZZ-P-20-B2-01-01 Masterplan - Proposed Level B2 Floor Plan **P01**

1709-SPP-DR-A-ZZ-P-20-0G-01-01 Masterplan - Proposed Level 0G Floor Plan **P01**

1709-SPP-DR-A-ZZ-P-20-01-01-01 Masterplan - Proposed Level 01 Floor Plan **P02**

1709-SPP-DR-A-ZZ-P-20-02-01-01 Masterplan - Proposed Level 02 Floor Pla **P02**

1709-SPP-DR-A-ZZ-P-20-2M-01-01 Masterplan - Proposed Level 02 Mezzanine Floor Plan **P01**

1709-SPP-DR-A-ZZ-P-20-03-01-01 Masterplan - Proposed Level 03 Floor Plan **P01**

1709-SPP-DR-A-ZZ-P-20-04-01-01 Masterplan - Proposed Level 04 Floor Plan **P01**

1709-SPP-DR-A-ZZ-P-20-05-01-01 Masterplan - Proposed Level 05 Floor Plan **P01**

1709-SPP-DR-A-ZZ-P-20-06-01-01 Masterplan - Proposed Level 06 Floor Plan **P01**

1709-SPP-DR-A-ZZ-P-20-07-01-01 Masterplan - Proposed Level 07 Floor Plan **P01**

1709-SPP-DR-A-ZZ-P-20-08-01-01 Masterplan - Proposed Level 08 Floor Plan **P01**

1709-SPP-DR-A-ZZ-P-20-09-01-01 Masterplan - Proposed Level 09 Floor Plan **P01**

1709-SPP-DR-A-ZZ-P-20-10-01-01 Masterplan - Proposed Level 10 Floor Plan **P01**

1709-SPP-DR-A-ZZ-P-20-11-01-01 Masterplan - Proposed Level 11 Floor Plan **P01**

1709-SPP-DR-A-ZZ-P-20-12-01-01 Masterplan - Proposed Level 12 Floor Plan **P01**

1709-SPP-DR-A-ZZ-P-20-13-01-01 Masterplan - Proposed Level 13 Floor Plan **P01**

1709-SPP-DR-A-ZZ-P-20-0R-01-01 Masterplan - Proposed Roof Plan **P01**

(P-25) Proposed Elevations

1709-SPP-DR-A-ZZ-P-25-XX-01-01 Masterplan - Proposed Streetscape SE Elevation **P01**

1709-SPP-DR-A-ZZ-P-25-XX-01-02 Masterplan - Proposed Streetscape NE Elevation **P02**

1709-SPP-DR-A-ZZ-P-25-XX-01-03 Masterplan - Proposed Streetscape NW Elevation **P01**

1709-SPP-DR-A-ZZ-P-25-XX-01-04 Masterplan - Proposed Streetscape SW Elevation **P01**

1709-SPP-DR-A-ZZ-P-25-XX-01-11 Masterplan - Proposed Streetscape SE & NE Elevations in Context **P02**

1709-SPP-DR-A-ZZ-P-25-XX-01-12 Masterplan - Proposed Streetscape NW & SW Elevations in Context **P01**

(P-26) Proposed Sections

1709-SPP-DR-A-ZZ-P-26-XX-01-01 Masterplan - Proposed Section S1 **P01**

1709-SPP-DR-A-ZZ-P-26-XX-01-02 Masterplan - Proposed Sections S2 & S3 **P01**

1709-SPP-DR-A-ZZ-P-26-XX-01-03 Masterplan - Proposed Section S4 **P01**

1709-SPP-DR-A-ZZ-P-26-XX-01-04 Masterplan - Proposed Sections S5 & S6 **P01**

1709-SPP-DR-A-ZZ-P-26-XX-01-05 Masterplan - Proposed Sections S7 & S8 **P01**

(P-80) Proposed Area Schedule

1709-SPP-SC-A-ZZ-P-80-XX-01-01 Masterplan - Proposed Area Schedule **P01**

(D-20) Demolition Plans

1709-SPP-DR-A-OW-D-20-0G-01-01 West - Demolition Level 0G Floor Plan **P01**

1709-SPP-DR-A-OW-D-20-0GM-01-01 West - Demolition Level 0G Mezzanine Floor Plan **P01**

1709-SPP-DR-A-OW-D-20-01-01-01 West - Demolition Level 01 Floor Plan **P01**

1709-SPP-DR-A-OW-E-20-1M-01-01 West - Demolition Level 01 Mezzanine Floor Plan 1 **P01**

1709-SPP-DR-A-OW-D-20-0R-01-01 West - Demolition Roof plan **P01**

(D-25) Demolition Elevations P01

1709-SPP-DR-A-OW-D-25-XX-01-01 West - Demolition NW & NE Elevations **P01**

1709-SPP-DR-A-OW-D-25-XX-01-02 West - Demolition SE & SW Elevations **P01**

(D-26) Demolition Sections

1709-SPP-DR-A-OW-D-26-XX-01-01 West - Demolition Section S1 & S2 **P01**

(P-00) Proposed Site

1709-SPP-DR-A-OW-P-00-OS-01-01 West - Proposed Site Plan **P01**

(P-20) Proposed Plans

1709-SPP-DR-A-OW-P-20-0G-01-01 West - Proposed Level 0G Floor Plan **P01**

1709-SPP-DR-A-OW-P-20-0GM-01-02 West - Proposed Level 0G Mezzanine Floor Plan **P01**

1709-SPP-DR-A-OW-P-20-01-01-01 West - Proposed Level 01 Floor Plan **P01**

1709-SPP-DR-A-OW-P-20-1M-01-02 West - Proposed Level 01 Mezzanine Floor Plan **P01**

1709-SPP-DR-A-OW-P-20-02-01-01 West - Proposed Level 02 Floor Plan **P01**

1709-SPP-DR-A-OW--P-20-03-01-01 West - Proposed Level 03 Floor Plan **P01**

1709-SPP-DR-A-OW-P-20-0R-01-01 West - Proposed Roof Plan **P01**

(P-21) Proposed External Wall Details

1709-SPP-DR-A-OW-P-21-XX-01-01 West - Proposed External Wall Details - Sheet 01 **P01**

1709-SPP-DR-A-OW-P-21-XX-01-02 West - Proposed External Wall Details - Sheet 02 **P01**

(P-25) Proposed Elevations

1709-SPP-DR-A-OW-P-25-XX-01-01 West - Proposed NW Elevation **P01**

1709-SPP-DR-A-OW-P-25-XX-01-02 West - Proposed NE Elevation **P01**

1709-SPP-DR-A-OW-P-25-XX-01-03 West - Proposed SE Elevation **P01**

1709-SPP-DR-A-OW-P-25-XX-01-04 West - Proposed SW Elevation **P01**

(P-26) Proposed Sections

1709-SPP-DR-A-OW-P-26-XX-01-01 West - Proposed Section S1 **P01**
1709-SPP-DR-A-OW-P-26-XX-01-02 West - Proposed Section S2 **P01**
1709-SPP-DR-A-OW-P-26-XX-01-03 West - Proposed Section S3 **P01**

(P-00) Proposed Site

1709-SPP-DR-A-GG-P-00-OS-01-01 G-Gate - Proposed Site Plan **P01**

(P-20) Proposed Plans

1709-SPP-DR-A-GG-P-20-B1-01-01 G-Gate - Proposed Level B1 Floor Plan **P01**
1709-SPP-DR-A-GG-P-20-B2-01-01 G-Gate - Proposed Level B2 Floor Plan **P01**
1709-SPP-DR-A-GG-P-20-0G-01-01 G-Gate - Proposed Level 0G Floor Plan **P01**
1709-SPP-DR-A-GG-P-20-01-01-01 G-Gate - Proposed Level 01 Floor Plan **P01**
1709-SPP-DR-A-GG-P-20-02-01-01 G-Gate - Proposed Level 02 Floor Plan **P01**
1709-SPP-DR-A-GG-P-20-03-01-01 G-Gate - Proposed Level 03 Plan **P01**
1709-SPP-DR-A-GG-P-20-04-01-01 G-Gate - Proposed Level 04 Floor Plan **P01**
1709-SPP-DR-A-GG-P-20-05-01-01 G-Gate - Proposed Level 05 Floor Plan **P01**
1709-SPP-DR-A-GG-P-20-06-01-01 G-Gate - Proposed Level 06 Floor Plan **P01**
1709-SPP-DR-A-GG-P-20-07-01-01 G-Gate - Proposed Level 07 Floor Plan **P01**
1709-SPP-DR-A-GG-P-20-08-01-01 G-Gate - Proposed Level 08 Floor Plan **P01**
1709-SPP-DR-A-GG-P-20-09-01-01 G-Gate - Proposed Level 09 Floor Plan **P01**
1709-SPP-DR-A-GG-P-20-0R-01-01 G-Gate - Proposed Roof Plan **P01**

(P-21) Proposed External Wall Details

1709-SPP-DR-A-GG-P-21-XX-01-01 G-Gate - Proposed External Wall Details **P01**

(P-25) Proposed Elevations

1709-SPP-DR-A-GG-P-25-XX-01-01 G-Gate - Proposed South Elevation **P01**
1709-SPP-DR-A-GG-P-25-XX-01-02 G-Gate - Proposed West Elevation **P01**
1709-SPP-DR-A-GG-P-25-XX-01-03 G-Gate - Proposed North Elevation **P01**
1709-SPP-DR-A-GG-P-25-XX-01-04 G-Gate - Proposed East Elevation **P01**

(P-26) Proposed Sections

1709-SPP-DR-A-GG-P-26-XX-01-01 G-Gate - Proposed Section S1 **P01**
1709-SPP-DR-A-GG-P-26-XX-01-02 G-Gate - Proposed Section S2 **P01**

(D-20) Demolition Plans

1709-SPP-DR-A-OC-D-20-B1-01-01 Central - Demolition Level B1 Floor Plan **P01**
1709-SPP-DR-A-OC-D-20-0G-01-01 Central - Demolition Level 0G Floor Plan **P01**
1709-SPP-DR-A-OC-D-20-01-01-01 Central - Demolition Level 01 Floor Plan **P01**
1709-SPP-DR-A-OC-D-20-1M-01-01 Central - Demolition Level 01 Mezzanine Floor Plan **P01**
1709-SPP-DR-A-OC-D-20-02-01-01 Central - Demolition Level 02 Floor Plan **P01**
1709-SPP-DR-A-OC-E-20-2M-01-01 Central - Demolition Level 02 Mezzanine Floor Plan **P01**
1709-SPP-DR-A-OC-D-20-03-01-01 Central - Demolition Level 03 Floor Plan **P01**
1709-SPP-DR-A-OC-D-20-04-01-01 Central - Demolition Level 04 Floor Plan **P01**
1709-SPP-DR-A-OC-D-20-0R-01-01 Central - Demolition Roof Plan **P01**

(D-25) Demolition Elevations

1709-SPP-DR-A-OC-D-25-XX-01-01 Central - Demolition SE & SW Elevations **P01**
1709-SPP-DR-A-OC-D-25-XX-01-02 Central - Demolition NE & NW Sectional Elevations **P01**

(D-26) Demolition Sections

1709-SPP-DR-A-OC-D-26-XX-01-01 Central - Demolition Section S1+S2 **P01**

(P-00) Proposed Site

1709-SPP-DR-A-OC-P-00-OS-01-01 Central - Proposed Site Plan **P01**

(P-20) Proposed Plans

1709-SPP-DR-A-OC-P-20-B1-01-01 Central - Proposed Level B1 Floor Plan **P01**

1709-SPP-DR-A-OC-P-20-B2-01-01 Central - Proposed Level B2 Floor Plan **P01**
1709-SPP-DR-A-OC-P-20-0G-01-01 Central - Proposed Level 0G Floor Plan **P01**
1709-SPP-DR-A-OC-P-20-01-01-01 Central - Proposed Level 01 Floor Plan **P01**
1709-SPP-DR-A-OC-P-20-02-01-01 Central - Proposed Level 02 Floor Plan **P01**
1709-SPP-DR-A-OC-P-20-2M-01-01 Central - Proposed Level 02 Mezzanine Floor Plan **P01**

1709-SPP-DR-A-OC-P-20-03-01-01 Central - Proposed Level 03 Floor Plan **P01**
1709-SPP-DR-A-OC-P-20-04-01-01 Central - Proposed Level 04 Floor Plan **P01**
1709-SPP-DR-A-OC-P-20-05-01-01 Central - Proposed Level 05 Floor Plan **P01**
1709-SPP-DR-A-OC-P-20-06-01-01 Central - Proposed Level 06 Floor Plan **P01**
1709-SPP-DR-A-OC-P-20-07-01-01 Central - Proposed Level 07 Floor Plan **P01**
1709-SPP-DR-A-OC-P-20-08-01-01 Central - Proposed Level 08 Floor Plan **P01**
1709-SPP-DR-A-OC-P-20-09-01-01 Central - Proposed Level 09 Floor Plan **P01**
1709-SPP-DR-A-OC-P-20-10-01-01 Central - Proposed Level 10 Floor Plan **P01**
1709-SPP-DR-A-OC-P-20-11-01-01 Central - Proposed Level 11 Floor Plan **P01**
1709-SPP-DR-A-OC-P-20-12-01-01 Central - Proposed Level 12 Floor Plan **P02**
1709-SPP-DR-A-OC-P-20-0R-01-01 Central - Proposed Roof Plan **P01**

(P-21) Proposed External Wall Details

1709-SPP-DR-A-OC-P-21-XX-01-01 Central - Proposed External Wall Details - Sheet 01 **P01**
1709-SPP-DR-A-OC-P-21-XX-01-02 Central - Proposed SW Elevation - Sheet 02 **P01**

(P-25) Proposed Elevations

1709-SPP-DR-A-OC-P-25-XX-01-01 Central - Proposed SE Elevation **P01**
1709-SPP-DR-A-OC-P-25-XX-01-02 Central - Proposed SW Elevation **P01**
1709-SPP-DR-A-OC-P-25-XX-01-03 Central - Proposed NW Elevation **P01**
1709-SPP-DR-A-OC-P-25-XX-01-04 Central - Proposed NE Elevation **P01**
1709-SPP-DR-A-OC-P-25-XX-01-32 Central - Façade Reinstatement **P01**

(P-26) Proposed Sections

1709-SPP-DR-A-OC-P-26-XX-01-01 Central - Proposed Section 01 **P01**
1709-SPP-DR-A-OC-P-26-XX-01-02 Central - Proposed Section 02 **P01**
1709-SPP-DR-A-OC-P-26-XX-01-03 Central - Proposed Section 03 **P01**

(D-20) Demolition Plans

1709-SPP-DR-A-OG-D-20-B1-01-01 Grand - Demolition Level B1 Floor Plan **P01**
1709-SPP-DR-A-OG-D-20-0G-01-01 Grand - Demolition Level 0G Floor Plan **P01**
1709-SPP-DR-A-OG-D-20-01-01-01 Grand - Demolition Level 01 Floor Plan **P01**
1709-SPP-DR-A-OG-D-20-01M-01-01 Grand - Demolition Level 01 Mezzanine Floor Plan **P01**
1709-SPP-DR-A-OG-D-20-0R-01-01 Grand - Demolition Roof **P01**

(D-25) Demolition Elevations

1709-SPP-DR-A-OG-D-25-XX-01-01 Grand - Demolition North Elevation **P01**
1709-SPP-DR-A-OG-D-25-XX-01-02 Grand - Demolition East Elevation **P01**
1709-SPP-DR-A-OG-D-25-XX-01-03 Grand - Demolition South Sectional Elevation **P01**
1709-SPP-DR-A-OG-D-25-XX-01-04 Grand - Demolition West Sectional Elevation **P01**

(D-26) Demolition Sections

1709-SPP-DR-A-OG-D-26-XX-01-01 Grand - Demolition Section S1 **P01**
1709-SPP-DR-A-OG-D-26-XX-01-02 Grand - Demolition Section S2 **P01**

(P-00) Proposed Site

1709-SPP-DR-A-OG-P-00-OS-01-01 Grand- Proposed Site Plan **P01**

(P-20) Proposed Plans

1709-SPP-DR-A-OG-P-20-B1-01-01 Grand - Proposed Level B1 Floor Plan **P01**
1709-SPP-DR-A-OG-P-20-0G-01-01 Grand - Proposed Level 0G Floor Plan **P01**

1709-SPP-DR-A-OG-E-20-0GM-01-01 Grand - Proposed Level 0G Mezzanine Floor Plan **P01**
1709-SPP-DR-A-OG-P-20-01-01-01 Grand - Proposed Level 01 Floor Plan **P01**
1709-SPP-DR-A-OG-P-20-01M-01-01 Grand - Proposed Level 01 Mezzanine Floor Plan **P01**
1709-SPP-DR-A-OG-P-20-0R-01-01 Grand - Proposed Roof Plan **P01**
(P-25) Proposed Elevations
1709-SPP-DR-A-OG-P-25-XX-01-01 Grand - Proposed North Elevation **P02**
1709-SPP-DR-A-OG-P-25-XX-01-02 Grand - Proposed East Elevation **P01**
1709-SPP-DR-A-OG-P-25-XX-01-03 Grand - Proposed South Sectional Elevation **P01**
1709-SPP-DR-A-OG-P-25-XX-01-04 Grand - Proposed West Sectional Elevation **P01**
1709-SPP-DR-A-OG-P-25-XX-01-20 Grand - Decorative Façade Reinstatement 1 **P02**
1709-SPP-DR-A-OG-P-25-XX-01-25 Grand - Decorative Façade Reinstatement 2 **P01**
(P-26) Proposed Sections
1709-SPP-DR-A-OG-P-26-XX-01-01 Grand - Proposed Section S1 **P01**
1709-SPP-DR-A-OG-P-26-XX-01-02 Grand - Proposed Section S2 **P01**
(D-20) Demolition Plans
1709-SPP-DR-A-ON-D-20-B1-01-01 National - Demolition Level B1 Floor Plan **P01**
1709-SPP-DR-A-ON-D-20-0G-01-01 National - Demolition Level 0G Floor Plan **P01**
1709-SPP-DR-A-ON-D-20-0GM-01-01 National - Demolition Level 0G Mezzanine Floor Plan **P01**
1709-SPP-DR-A-ON-D-20-01-01-01 National - Demolition Level 01 Floor Plan **P01**
1709-SPP-DR-A-ON-D-20-0R-01-01 National - Demolition Roof plan **P01**
(D-25) Demolition Elevations
1709-SPP-DR-A-ON-D-25-XX-01-01 National - Demolition NW Sectional Elevation **P01**
1709-SPP-DR-A-ON-D-25-XX-01-02 National - Demolition NE Elevation **P01**
1709-SPP-DR-A-ON-D-25-XX-01-03 National - Demolition SE Elevation 1 **P01**
1709-SPP-DR-A-ON-D-25-XX-01-04 National - Demolition SW Sectional Elevation **P01**
(D-26) Demolition Sections
1709-SPP-DR-A-ON-D-26-XX-01-01 National - Demolition Section S1 **P01**
1709-SPP-DR-A-ON-D-26-XX-01-02 National - Demolition Section S2 **P01**
(P-00) Proposed Site
1709-SPP-DR-A-ON-P-00-OS-01-01 National - Proposed Site Plan **P01**
(P-20) Proposed Plans
1709-SPP-DR-A-ON-P-20-B1-01-01 National - Proposed Level B1 Floor Plan **P01**
1709-SPP-DR-A-ON-P-20-0G-01-01 National - Proposed Level 0G Floor Plan **P01**
1709-SPP-DR-A-ON-P-20-01-01-01 National - Proposed Level 01 Floor Plan **P01**
1709-SPP-DR-A-ON-P-20-02-01-01 National - Proposed Level 02 Floor Plan **P01**
1709-SPP-DR-A-ON-P-20-03-01-01 National - Proposed Level 03 Floor Plan **P01**
1709-SPP-DR-A-ON-P-20-04-01-01 National - Proposed Level 04 Floor Plan **P01**
1709-SPP-DR-A-ON-P-20-05-01-01 National - Proposed Level 05 Floor Plan **P01**
1709-SPP-DR-A-ON-P-20-0R-01-01 National - Proposed Roof Plan **P01**
(P-21) Proposed External Wall Details
1709-SPP-DR-A-ON-P-21-XX-01-01 National - Proposed External Wall Details - Sheet 01 **P01**
1709-SPP-DR-A-ON-P-21-XX-01-02 National - Proposed External Wall Details - Sheet 02 **P01**
(P-25) Proposed Elevations
1709-SPP-DR-A-ON-P-25-XX-01-01 National - Proposed NW Sectional Elevation **P01**
1709-SPP-DR-A-ON-P-25-XX-01-02 National - Proposed NE Elevation **P01**
1709-SPP-DR-A-ON-P-25-XX-01-03 National - Proposed SE Elevation **P01**
1709-SPP-DR-A-ON-P-25-XX-01-04 National - Proposed SW Sectional Elevation **P01**

1709-SPP-DR-A-ON-P-25-XX-01-05 National - Proposed NW Sectional Elevation - Sheet 02 **P01**

(P-26) Proposed Sections

1709-SPP-DR-A-ON-P-26-XX-01-01 National - Proposed Section 01 **P01**

1709-SPP-DR-A-ON-P-26-XX-01-02 National - Proposed Section 02 **P01**

1709-SPP-DR-A-ON-P-26-XX-01-03 National - Proposed Section 03 1:200 A1 **P01**

(D-20) Demolition Plans

1709-SPP-DR-A-PH-D-20-B1-01-01 Pillar Hall - Demolition Level B1 Floor Plan **P01**

1709-SPP-DR-A-PH-D-20-0G-01-01 Pillar Hall - Demolition Level 0G Floor Plan **P01**

1709-SPP-DR-A-PH-D-20-01-01-01 Pillar Hall - Demolition Level 01 Floor Plan **P01**

1709-SPP-DR-A-PH-D-20-02-01-01 Pillar Hall - Demolition Level 02 Floor Plan **P01**

1709-SPP-DR-A-PH-D-20-03-01-01 Pillar Hall - Demolition Level 03 Floor Plan **P01**

1709-SPP-DR-A-PH-D-20-04-01-01 Pillar Hall - Demolition Level 04 Floor Plan **P01**

1709-SPP-DR-A-PH-D-20-0R-01-01 Pillar Hall - Demolition Roof plan **P01**

(D-25) Demolition Elevations

1709-SPP-DR-A-PH-D-25-XX-01-01 Pillar Hall - Demolition North Elevation **P01**

1709-SPP-DR-A-PH-D-25-XX-01-02 Pillar Hall - Demolition West Elevation **P01**

1709-SPP-DR-A-PH-D-25-XX-01-03 Pillar Hall - Demolition South Elevation **P01**

1709-SPP-DR-A-PH-D-25-XX-01-04 Pillar Hall - Demolition East Elevation **P02**

(D-26) Demolition Sections

1709-SPP-DR-A-PH-D-26-XX-01-01 Pillar Hall - Demolition Section S1 **P01**

(P-00) Proposed Site

1709-SPP-DR-A-PH-P-00-OS-01-01 Pillar Hall - Proposed Site Plan **P01**

(P-20) Proposed Plans

1709-SPP-DR-A-PH-P-20-B1-01-01 Pillar Hall - Proposed Level B1 Floor Plan **P01**

1709-SPP-DR-A-PH-P-20-0G-01-01 Pillar Hall - Proposed Level 0G Floor Plan **P01**

1709-SPP-DR-A-PH-P-20-01-01-01 Pillar Hall - Proposed Level 01 Floor Plan **P01**

1709-SPP-DR-A-PH-P-20-02-01-01 Pillar Hall - Proposed Level 02 Floor Plan **P01**

1709-SPP-DR-A-PH-P-20-03-01-01 Pillar Hall - Proposed Level 03 Floor Plan **P01**

1709-SPP-DR-A-PH-P-20-04-01-01 Pillar Hall - Proposed Level 04 Floor Plan **P01**

1709-SPP-DR-A-PH-P-20-0R-01-01 Pillar Hall - Proposed Roof Plan **P01**

(P-25) Proposed Elevations

1709-SPP-DR-A-PH-P-25-XX-01-01 Pillar Hall - Proposed North Elevation **P01**

1709-SPP-DR-A-PH-P-25-XX-01-02 Pillar Hall - Proposed West Elevation **P01**

1709-SPP-DR-A-PH-P-25-XX-01-03 Pillar Hall - Proposed South Elevation **P01**

1709-SPP-DR-A-PH-P-25-XX-01-04 Pillar Hall - Proposed East Elevation **P02**

(P-26) Proposed Sections

1709-SPP-DR-A-PH-P-26-MF-01-01 Pillar Hall - Proposed Section S1 **P01**

D-20) Demolition Plans

1709-SPP-DR-A-CP-D-20-0B-01-01 MSCP - Demolition Level B1 Floor Plan **P01**

1709-SPP-DR-A-CP-D-20-0G-01-01 MSCP - Demolition Level 0G Floor Plan **P01**

1709-SPP-DR-A-CP-D-20-01-01-01 MSCP - Demolition Level 01 Floor Plan **P01**

1709-SPP-DR-A-CP-D-20-02-01-01 MSCP - Demolition Level 02 Floor Plan **P01**

1709-SPP-DR-A-CP-D-20-03-01-01 MSCP - Demolition Level 03 Floor Plan **P01**

1709-SPP-DR-A-CP-D-20-04-01-01 MSCP - Demolition Level 04 Floor Plan **P01**

1709-SPP-DR-A-CP-D-20-05-01-01 MSCP - Demolition Level 05 Floor Plan **P01**

1709-SPP-DR-A-CP-D-20-0R-01-01 MSCP - Demolition Roof plan **P01**

(D-25) Demolition Elevations

1709-SPP-DR-A-CP-D-25-XX-01-01 MSCP - Demolition North Elevation **P01**

1709-SPP-DR-A-CP-D-25-XX-01-02 MSCP - Demolition South Elevation **P01**

1709-SPP-DR-A-CP-D-25-XX-01-03 MSCP - Demolition East & West Elevations **P01**

(D-26) Demolition Sections

1709-SPP-DR-A-CP-D-26-XX-01-01 MSCP - Demolition Section S1 **P01**
1709-SPP-DR-A-CP-D-26-XX-01-02 MSCP - Demolition Sections S2 & **P01**

(P-00) Proposed Site

1709-SPP-DR-A-CP-P-00-OS-01-01 MSCP - Proposed Site Plan **P01**

(P-20) Proposed Plans

1709-SPP-DR-A-CP-P-20-B1-01-01 MSCP - Proposed Level B1 Floor Plan **P01**
1709-SPP-DR-A-CP-P-20-0G-01-01 MSCP - Proposed Level 0G Floor Plan **P01**
1709-SPP-DR-A-CP-P-20-01-01-01 MSCP - Proposed Level 01 Floor Plan **P01**
1709-SPP-DR-A-CP-P-20-02-01-01 MSCP - Proposed Level 02 Floor Plan **P01**
1709-SPP-DR-A-CP-P-20-03-01-01 MSCP - Proposed Level 03 Floor Plan **P01**
1709-SPP-DR-A-CP-P-20-04-01-01 MSCP - Proposed Level 04 Floor Plan **P01**
1709-SPP-DR-A-CP-P-20-05-01-01 MSCP - Proposed Level 05 Floor Plan **P02**
1709-SPP-DR-A-CP-P-20-06-01-01 MSCP - Proposed Level 06 Floor Plan **P01**
1709-SPP-DR-A-CP-P-20-07-01-01 MSCP - Proposed Level 07 Floor Plan 1 **P01**
1709-SPP-DR-A-CP-P-20-0R-01-01 MSCP - Proposed Roof Plan **P02**

(P-21) Proposed External Wall Details

1709-SPP-DR-A-CP-P-21-XX-01-01 MSCP - Proposed External Wall Details **P01**

(P-25) Proposed Elevations

1709-SPP-DR-A-CP-P-25-XX-01-01 MSCP - Proposed North Elevation **P01**
1709-SPP-DR-A-CP-P-25-XX-01-02 MSCP - Proposed South Elevation **P01**
1709-SPP-DR-A-CP-P-25-XX-01-03 MSCP - Proposed East & West Elevations **P01**

(P-26) Proposed Sections

1709-SPP-DR-A-CP-P-26-XX-01-01 MSCP - Proposed Section S1 **P01**
1709-SPP-DR-A-CP-P-26-XX-01-02 MSCP - Proposed Sections S2 & S3 **P01**

(P-00) Proposed Site

1709-SPP-DR-A-LY-P-00-OS-01-01 L-Yard - Proposed Site Plan **P01**

(P-20) Proposed Plans

1709-SPP-DR-A-LY-P-20-0G-01-01 L-Yard - Proposed Level 0G Floor Plan **P01**
1709-SPP-DR-A-LY-P-20-01-01-01 L-Yard - Proposed Level 01 Floor Plan **P01**
1709-SPP-DR-A-LY-P-20-1M-01-01 L-Yard - Proposed Level 01 Mezzanine Floor Plan **P01**
1709-SPP-DR-A-LY-P-20-02-01-01 L-Yard Proposed Level 02 Floor Plan **P01**

(P-25) Proposed Elevations

1709-SPP-DR-A-LY-P-25-XX-01-01 L-Yard - Proposed North Elevation **P01**
1709-SPP-DR-A-LY-P-25-XX-01-02 L-Yard - Proposed East Sectional Elevation **P01**
1709-SPP-DR-A-LY-P-25-XX-01-03 L-Yard - Proposed South Sectional Elevation **P01**
1709-SPP-DR-A-LY-P-25-XX-01-04 L-Yard - Proposed West Sectional Elevation **P01**

(P-00) Proposed Site

1709-SPP-DR-A-PR-P-00-OS-01-01 L2 Public Realm - Proposed Site Plan **P01**

(P-20) Proposed Plans

1709-SPP-DR-A-PR-P-20-02-01-01 L2 Public Realm - Proposed Level 02 Floor Plan **P01**
1709-SPP-DR-A-PR-P-20-2M-01-02 L2 Public Realm - Proposed Level 02 Mezzanine Floor Plan 1:200 A1 **P01**
1709-SPP-DR-A-PR-P-20-0R-01-01 L2 Public Realm - Proposed Roof Plan **P01**

(P-25) Proposed Elevations

1709-SPP-DR-A-PR-P-25-XX-01-01 L2 Public Realm - Proposed North Sectional Elevation **P01**
1709-SPP-DR-A-PR-P-25-XX-01-02 L2 Public Realm - Proposed East Elevation **P01**
1709-SPP-DR-A-PR-P-25-XX-01-03 L2 Public Realm - Proposed South Sectional Elevation **P01**

1709-SPP-DR-A-PR-P-25-XX-01-04 L2 Public Realm - Proposed West Sectional Elevation **P01**

(P-26) Proposed Sections

1709-SPP-DR-A-PR-P-26-XX-01-01 L2 Public Realm - Proposed Section 01 **P01**

1709-SPP-DR-A-PR-P-26-XX-01-02 L2 Public Realm - Proposed Section 02 **P01**

Reason: To ensure full compliance with the planning application hereby approved and to prevent harm arising through deviations from the approved plans, in accordance with Policies 7.1, 7.2, 7.3, 7.4, 7.5, 7.6, 7.7, 7.8, 7.9 and 7.21 of the London Plan 2016 and Policies DC1, DC2, DC3, DC4 and DC8 of the Local Plan 2018.

3. Phasing/Programme

Prior to commencement of each Phase of the Development, a programme of works for that Phase shall be submitted to and approved in writing by the Council. The details shall include a complete programme for the delivery of each respective Phase, in accordance with the provisions and the assessment carried out in the Environmental Statement (dated September 2018) and Draft Construction Management Plan (dated September 2018) hereby approved or any subsequent amendments approved by the Council. The works in each Phase shall be carried out in accordance with the approved programme.

Reason: To assist with the identification of each chargeable development (being the Phase) and the calculation of the amount of CIL payable in respect of each chargeable development in accordance with the Community Infrastructure Levy Regulations 2010 (as amended).

4. Business and Community Liaison Groups

For the duration of each Phase of works hereby approved and up to two years after occupation of the final Phase of development, the applicant will establish and maintain Business and Community Liaison Groups having the purpose of:

- (i) informing nearby residents and businesses of the programme of works for the Development;
- (ii) informing nearby residents and businesses of progress of each Phase;
- (iii) informing nearby residents and businesses of appropriate mitigation measures being undertaken as part of the Development;
- (iv) informing nearby residents and businesses of considerate methods of working such as working hours and site traffic;
- (v) providing advanced notice of exceptional hours of work, if and when appropriate;
- (vi) providing nearby residents and businesses with an initial contact for information relating to each Phase of works for the Development and procedures for receiving/responding to comments or complaints regarding the Development with the view of resolving any concerns that might arise;

- (vii) providing telephone contacts for nearby residents and businesses 24-hours daily throughout each Phase of works for the Development; and
- (viii) producing a leaflet prior to each Phase of the Development for distribution to nearby residents and businesses, identifying progress of the Development and which shall include an invitation to register an interest in the Liaison Groups.

The terms of reference for the Business and Community Liaison Groups shall be submitted to the Council for approval prior to Commencement of any works on site. The Business and Community Liaison Groups shall meet at least once every quarter for the first year, and at least twice a year until completion.

Reason: To ensure satisfactory communication with residents, businesses, and local stakeholders throughout the construction of the development, in accordance with the Policies CC11, CC12, CC13, DC2, T7 and CF3 of the Local Plan 2018.

5. Hoardings

Prior to commencement of each Phase of development a scheme including detailed drawings in plan, section, and elevation for temporary fencing and/or enclosure of the site shall be submitted to and approved in writing by the Council. The temporary fencing and/or enclosure shall be painted timber and must be erected prior to commencement of each phase in accordance with the approved details. The temporary fencing and/or enclosure shall thereafter be retained for the duration of the demolition and building works in accordance with the approved details. No part of the temporary fencing and/or enclosure of the site shall be used for the display of advertisement hoardings, unless consent is sought from the Council.

Reason: To ensure a satisfactory external appearance and to prevent harm to the street scene and public realm, in accordance with Policies 7.1 and 7.6 of the London Plan, Policy DC1 and DC8 of the Local Plan 2018 and Key Principles of the Planning Guidance SPD (2018).

6. TFL – London Underground Infrastructure Request

The development hereby permitted shall not be commenced until detailed design and method statements (in consultation with London Underground) for the relevant parts of each Phase of the development for all of the demolition, foundations, basement and ground floor structures, or for any other structures below ground level, including piling (temporary and permanent), have been submitted to and approved in writing by the Council which:

- provide details on all structures
- provide details on the use of tall plant/scaffolding
- accommodate the location of the existing London Underground structures
- there should be no opening windows or balconies facing the LU operational railway elevation
- demonstrate that there will at no time be any potential security risk to our railway, property or structures
- accommodate ground movement arising from the construction thereof
- mitigate the effects of noise and vibration arising from the adjoining operations within the structures

The development of the relevant Phase shall thereafter be carried out in all respects in accordance with the approved design and method statements, and all structures and works comprised within each building forming part of that Phase hereby permitted which are required by the approved design statements in order to procure the matters mentioned in paragraphs of this condition shall be completed, in their entirety, before any part of the building hereby permitted is occupied.

Reason: To ensure that the development does not impact on existing London Underground transport infrastructure, in accordance with London Plan 2015 Table 6.1, draft London Plan policy T3 and 'Land for Industry and Transport' Supplementary Planning Guidance 2012.

7. Demolition Method Statement

(i) Prior to commencement of demolition works of each Phase (excluding Enabling Works) a Demolition Method Statement for that Phase shall be submitted to and approved in writing by the Council. Details shall include control measures for dust, noise, vibration, lighting, delivery locations, restriction of hours of work and all associated activities audible beyond the site boundary to 0800-1800hrs Mondays to Fridays and 0800-1300hrs on Saturdays, advance notification to neighbours and other interested parties of proposed works and public display of contact details including accessible phone contact to persons responsible for the site works for the duration of the works.

(ii) No demolition, within each Phase, shall commence until a risk assessment based on the Mayor's Best Practice Guidance (The control of dust and emissions from construction and demolition) has been undertaken and a method statement for emissions control (including an inventory and timetable of dust generating activities, emission control methods and where appropriate air quality monitoring) for that Phase has been submitted to and approved in writing by the council. The appropriate mitigation measures to minimise dust and emissions must be incorporated into the site-specific Demolition Method Statement and Construction Management Plan. Developers must ensure that on-site contractors follow best practicable means to minimise dust and emissions at all times. Demolition works shall be undertaken in accordance with the approved details.

Reason: To ensure that occupiers of surrounding premises are not adversely affected by noise, vibration, dust, lighting or other emissions from the building site in accordance with policies 5.18, 5.19, 5.20, 5.21, 5.22 and 7.14 of the London Plan, Policies DC1, DC2, CC6, CC7, CC10, CC11, and CC12 of the Local Plan 2018.

8. Demolition Logistics Plan

Each of the Phases (excluding Enabling Works) shall not Commence until a Demolition Logistics Plan (DLP) covering that Phase has been submitted to and approved in writing by the Council.

The works shall be carried out in accordance with the approved DLP for each Stage identified above and shall cover the following minimum requirements:

- the estimated number, size and routes of demolition and construction vehicles per day/week;

- details of a Low Emission Vehicle Strategy;
- details of the access arrangements and delivery locations on the site;
- details of any vehicle holding areas; and
- other matters relating to traffic management to be agreed as required.

The DLP shall identify efficiency and sustainability measures to be undertaken for the works. The approved details shall be undertaken in accordance with the terms and throughout the period set out in the DLP.

Reason: To ensure that occupiers of surrounding premises are not adversely affected by noise, vibration, dust, lighting, or other emissions from the building site in accordance with Policies 6.11 and 6.12 of the London Plan and T1, T6 and T7 of the Local Plan 2018.

9. Construction Management Plan

Prior to commencement of each Phase of development (excluding Enabling Works), a Construction Management Plan shall be submitted to and approved in writing by the Council. Details shall include control measures for dust, noise, vibration, lighting, delivery locations, restriction of hours of work and all associated activities audible beyond the site boundary to 0800-1800hrs Mondays to Fridays and 0800-1300hrs on Saturdays, advance notification to neighbours and other interested parties of proposed works and public display of contact details including accessible phone contact to persons responsible for the site works for the duration of the works. The construction management plan should include the details for all the relevant foundations, basement and ground floor structures, or for any other structures below ground level, including piling (temporary and permanent). Approved details for each relevant phase, or part thereof shall be implemented throughout the project period.

Reason: To ensure that occupiers of surrounding premises are not adversely affected by noise, vibration, dust, lighting, or other emissions from the building site in accordance with policies 5.18, 5.19, 5.20, 5.21 and 5.22 of the London Plan, Policies DC1, DC12, CC6, CC7, CC10, CC11 and CC12 of the Local Plan 2018 and Key Principles of the Planning Guidance SPD (2018).

10. Construction Logistics Plan

Prior to commencement of each Phase of development (excluding Enabling Works), a Construction Logistics Plan for that Phase shall be submitted to and approved in writing by the Council. The method statement /construction management plan should include the details for all the relevant foundations, basement and ground floor structures, or for any other structures below ground level, including piling (temporary and permanent). The development of the relevant Phase shall be carried out in accordance with the relevant approved Construction Logistics Management Plan unless otherwise agreed in writing with the Council. Each Construction Logistics Plan shall cover the following minimum requirements:

- site logistics and operations;
- construction vehicle routing;
- contact details for site managers and details of management lines of reporting;
- detailed plan showing phasing;

- location of site offices, ancillary buildings, plant, wheel-washing facilities, stacking bays and car parking;
- storage of any skips, oil and chemical storage etc.; and
- access and egress points;
- membership of the Considerate Contractors Scheme.

Reason: To ensure that no unacceptable adverse effect on the amenity of surrounding occupiers in accordance with Policies 6.11 and 6.12 of the London Plan and T1, T6 and T7 of the Local Plan 2018.

11. Archaeology (GLAAS)

Prior to commencement of each Phase of development (excluding Enabling Works), a Written Scheme of Investigation (WSI) shall be submitted to and approved in writing by the Council. For land that is included within the WSI, no development shall take place within the relevant Phase other than in accordance with the agreed WSI, which shall include the statement of significance and research objectives, and

A. The programme and methodology of site investigation and recording and the nomination of a competent person(s) or organisation to undertake the agreed works

B. The programme for post-investigation assessment and subsequent analysis, publication & dissemination, and deposition of resulting material. this part of the condition shall not be discharged until these elements have been fulfilled in accordance with the programme set out in the WSI

Reason: Heritage assets of archaeological interest may survive on the site. The Council wishes to secure the provision of appropriate archaeological investigation, including the publication of results, in accordance with Section 12 of the NPPF, Policy 7.8 of the London Plan, Policies DC1, DC8 of the Local Plan 2018 and key principles within the Planning Guidance Supplementary Planning Document 2018.

12. Preliminary Risk Assessment Report

No development (except Enabling Works) shall commence within each Phase of development until a preliminary risk assessment report for that Phase is submitted to and approved in writing by the Council. This report shall comprise: a desktop study which identifies all current and previous uses at the site and surrounding area as well as the potential contaminants associated with those uses; a site reconnaissance; and a conceptual model indicating potential pollutant linkages between sources, pathways and receptors, including those in the surrounding area and those planned at the site; and a qualitative risk assessment of any potentially unacceptable risks arising from the identified pollutant linkages to human health, controlled waters and the wider environment including ecological receptors and building materials. All works must be carried out in compliance with and by a competent person who conforms to CLR 11: Model Procedures for the Management of Land Contamination (Defra 2004) or the current UK requirements for sampling and testing.

Reason: Potentially contaminative land uses (past or present) are understood to occur at, or near to, this site. This condition is required to ensure that no unacceptable risks are caused to humans, controlled waters or the wider environment during and following

the development works, in accordance with Policies CC9 and CC13 of the Local Plan 2018 and SPD Key Principles LC1 to LC7 2018.

13. Site Investigation Scheme

No development (except Enabling Works) shall commence within each Phase of development until a site investigation scheme for that Phase is submitted to and approved in writing by the Council. This scheme shall be based upon and target the risks identified in the approved preliminary risk assessment for that Phase and shall provide provisions for, where relevant, the sampling of soil, soil vapour, ground gas, surface, and groundwater. All works must be carried out in compliance with and by a competent person who conforms to CLR 11: Model Procedures for the Management of Land Contamination (Defra 2004) or the current UK requirements for sampling and testing.

Reason: Potentially contaminative land uses (past or present) are understood to occur at, or near to, this site. This condition is required to ensure that no unacceptable risks are caused to humans, controlled waters or the wider environment during and following the development works, in accordance with Policies CC9 and CC13 of the Local Plan 2018 and SPD Key Principles LC1 to LC7 2018.

14. Quantitative Risk Assessment Report

Unless the Council agree in writing that a set extent of development must commence to enable compliance with this condition, no development (except Enabling Works) shall commence within each Phase of development, following a site investigation undertaken in compliance with the approved site investigation scheme, a quantitative risk assessment report is submitted to and approved in writing by the Council. This report shall: assess the degree and nature of any contamination identified on the site through the site investigation; include a revised conceptual site model from the preliminary risk assessment based on the information gathered through the site investigation to confirm the existence of any remaining pollutant linkages and determine the risks posed by any contamination to human health, controlled waters and the wider environment. All works must be carried out in compliance with and by a competent person who conforms to CLR 11: Model Procedures for the Management of Land Contamination (Defra 2004) or the current UK requirements for sampling and testing.

Reason: Potentially contaminative land uses (past or present) are understood to occur at, or near to, this site. This condition is required to ensure that no unacceptable risks are caused to humans, controlled waters or the wider environment during and following the development works, in accordance with Policies CC9 and CC13 of the Local Plan 2018 and SPD Key Principles LC1 to LC7 2018.

15. Remediation Method Statement

Unless the Council agree in writing that a set extent of development must commence to enable compliance with this condition, no development (except Enabling Works) shall commence within each Phase of development until, a remediation method statement for that Phase is submitted to and approved in writing by the Council. This statement shall detail any required remediation works and shall be designed to mitigate any remaining risks identified in the approved quantitative risk assessment. All works must be carried out in compliance with and by a competent person who conforms to CLR 11: Model

Procedures for the Management of Land Contamination (Defra 2004) or the current UK requirements for sampling and testing.

Reason: Potentially contaminative land uses (past or present) are understood to occur at, or near to, this site. This condition is required to ensure that no unacceptable risks are caused to humans, controlled waters or the wider environment during and following the development works, in accordance with Policies CC9 and CC13 of the Local Plan 2018 and SPD Key Principles LC1 to LC7 2018.

16. Verification Report

Unless the Council agree in writing that a set extent of development must commence to enable compliance with this condition, no development (except Enabling Works) shall commence within each Phase of development until the approved remediation method statement for that Phase has been carried out in full and a verification report confirming these works has been submitted to, and approved in writing, by the Council. This report shall include: details of the remediation works carried out; results of any verification sampling, testing or monitoring including the analysis of any imported soil; all waste management documentation showing the classification of waste, its treatment, movement and disposal; and the validation of gas membrane placement. If, during development, contamination not previously identified is found to be present at the site, the Council is to be informed immediately and no further development (unless otherwise agreed in writing by the Council) shall be carried out until a report indicating the nature of the contamination and how it is to be dealt with is submitted to, and agreed in writing by, the Council. Any required remediation shall be detailed in an amendment to the remediation statement and verification of these works included in the verification report. All works must be carried out in compliance with and by a competent person who conforms to CLR 11: Model Procedures for the Management of Land Contamination (Defra 2004) or the current UK requirements for sampling and testing.

Reason: Potentially contaminative land uses (past or present) are understood to occur at, or near to, this site. This condition is required to ensure that no unacceptable risks are caused to humans, controlled waters or the wider environment during and following the development works, in accordance with Policies CC9 and CC13 of the Local Plan 2018 and SPD Key Principles LC1 to LC7 2018.

17. Onward Long-Term Monitoring Methodology Report

Unless the Council agree in writing that a set extent of development must commence to enable compliance with this condition, no development (except Enabling Works) shall commence within each Phase of development until an onward long-term monitoring methodology report is submitted to and approved in writing by the Council where further monitoring is required past the completion of development works to verify the success of the remediation undertaken. A verification report of these monitoring works shall then be submitted to and approved in writing by the Council when it may be demonstrated that no residual adverse risks exist. All works must be carried out in compliance with and by a competent person who conforms to CLR 11: Model Procedures for the Management of Land Contamination (Defra 2004) or the current UK requirements for sampling and testing.

Reason: Potentially contaminative land uses (past or present) are understood to occur at, or near to, this site. This condition is required to ensure that no unacceptable risks

are caused to humans, controlled waters or the wider environment during and following the development works, in accordance with Policies CC9 and CC13 of the Local Plan 2018 and SPD Key Principles LC1 to LC7 2018.

18. Piling Method Statement

No impact piling shall take place until a piling method statement (detailing the type of piling to be undertaken and the methodology by which such piling will be carried out within each Phase (where relevant) including measures to prevent and minimise the potential for damage to subsurface water or sewerage infrastructure, and the programme for the works) has been submitted to and approved in writing by the Council in consultation with the relevant water or sewerage undertaker. Any piling must be undertaken in accordance with the terms of the approved piling method statement.

Reason: To prevent any potential to impact on local underground water and sewerage utility infrastructure, in accordance with Policies 5.14 and 5.15 of the London Plan, Policies CC3 and CC5 of the Local Plan 2018. The applicant is advised to contact Thames Water Developer Services on 0845 850 2777 to discuss the details of the piling method statement.

19. Revised Drainage Strategy

Prior to commencement of each Phase of development hereby permitted (excluding Enabling Works and Phase 1) a revised drainage strategy detailing any on and/or off-site drainage works, shall be submitted to and approved in writing by the Council in consultation with the sewerage undertaker. No discharge of foul or surface water from the site shall be accepted into the public system until the drainage works referred to in the strategy have been completed. Details shall be implemented in accordance with the approved details and thereafter permanently retained in this form.

Reason: To ensure that sufficient drainage capacity is made available to cope with the new development; and to avoid adverse environmental impact upon the community in accordance with Policy 5.13 of the London Plan and Policy CC3 and CC5 of the Local Plan 2018.

20. Sustainable Drainage Strategy (SuDS)

Prior to commencement of each Phase of development (excluding Enabling Works and Phase 1), a revised Sustainable Drainage Strategy (SuDS), which details how surface water will be managed on-site in-line with the London Plan Drainage Hierarchy's preferred SuDS measures, shall be submitted to and approved in writing by the Council. Information shall include details on the design, location and attenuation capabilities of the proposed sustainable drainage measures such as permeable surfaces, including green roofs. Details of the proposed flow controls and flow rates for any discharge of surface water to the combined sewer system should also be provided, with the aim of achieving greenfield rates for final discharges. Where feasible, rainwater harvesting should also be integrated to collect rainwater for re-use in the site. The Strategy shall be implemented in accordance with the approved details, and thereafter all SuDS measures shall be retained and maintained in accordance with the approved details and shall thereafter be permanently retained in this form.

Reason: To prevent any increased risk of flooding and to ensure the satisfactory storage of/disposal of surface water from the site in accordance with Policy 5.13 of The London Plan; and Policy CC3 of the Local Plan 2018.

21. Revised Flood Risk Assessment

Prior to commencement of each Phase of development (excluding Enabling Works) a revised Flood Risk Assessment shall be submitted to and approved in writing by the Council. Details shall be implemented in accordance with the approved details and thereafter permanently retained in this form.

Reason: To reduce the impact of flooding to the proposed development and future occupants, in accordance with Policies 5.11, 5.13, 5.14 and 5.15 London Plan, and Policy CC3 of the Local Plan 2018

22. Green / Brown/Roofs

Prior to commencement of each Phase of development (excluding Enabling Works and Phase 1), details of all green/brown roofs within that Phase, including the identification of further opportunities for green roofs, including details of types of green roofs and a planting maintenance plan shall be submitted to and approved in writing by the Council. Development within that Phase shall not be occupied until the scheme has been carried out in accordance with the approved details, and shall thereafter be permanently retained in this form.

Reason: To ensure the provision of green roofs in the interests of sustainable urban drainage and habitat provision, in accordance with Policies 5.11, 5.13 and 7.19 of the London Plan and Policy OS5 and CC4 of the Local Plan 2018.

23. Sustainability

Prior to commencement of each Phase of development (excluding Enabling Works and Phase 1), revised Sustainability Statements and BREEAM assessments for that Phase shall be submitted to and approved in writing by the Council to confirm the sustainable design and construction measures to be integrated. The associated BREEAM ratings for the offices and retail spaces and any other non-residential uses should achieve the "Very Good" rating as minimum. Residential units should achieve similarly high standards of sustainability.

Within 6 months of occupation of any use or occupation of each development Phase hereby permitted, a BREEAM (2014) certificate confirming that sustainability performance (Very Good or Excellent) had been achieved as proposed shall be submitted to and approved in writing by the Council. Supporting information shall also be submitted for approval to demonstrate that the residential units meet the minimum sustainable design and construction standards of the London Plan.

Reason: In the interests of energy conservation, reduction of CO2 emissions and wider sustainability, in accordance with Policies 5.1, 5.2, 5.3, 5.6 and 5.7 of the London Plan and Policies CC1, CC2 of the Local Plan 2018.

24. Updated Energy Strategy

Prior to commencement of Phase 2 of the development, a revised Energy Strategy for the development shall be submitted to and approved in writing by the Council. The revised strategy shall include details of energy efficiency and low/zero carbon technologies and confirm that CO2 emissions will be reduced in line with the London Plan targets. No part of the development shall be used or occupied until it has been carried out in accordance with the approved details and shall thereafter be permanently retained in this form.

Reason: In the interests of energy conservation and reduction of CO2 emissions, in accordance with Policies 5.1, 5.2, 5.3, 5.6 and 5.7 of the London Plan, Policy CC1 of the Local Plan 2018.

25. Secure by Design

Prior to commencement of development (excluding Enabling Works and Phase 1), a statement of how 'Secure by Design' requirements are to be adequately achieved shall be submitted to and approved in writing by the Council. Such details shall include, but not be limited to: site wide public realm CCTV and feasibility study relating to linking CCTV with the Council's borough wide CCTV system, access controls, basement security measures and means to secure the site throughout construction in accordance with BS8300:2009. No part of the development within that Phase shall be used or occupied until these measures have been implemented in accordance with the approved details, and the measures shall thereafter be permanently retained in this form.

Reason: To ensure that the development incorporates suitable design measures to minimise opportunities for, and the perception of crime and provide a safe and secure environment, in accordance with Policy 7.3 of the London Plan, and Policies DC1 and DC8 of the Local Plan 2018.

26. External noise from machinery, extract/ventilation ducting, mechanical gates, etc.

Prior to commencement of the relevant part of each Phase of the development (excluding Enabling Works and Phase 1), details shall be submitted to and approved in writing by the Council, of the external sound level emitted from plant/ machinery/ equipment and mitigation measures as appropriate. The measures shall ensure that the external sound level emitted from plant, machinery/ equipment will be lower than the lowest existing background sound level by at least 10dBA in order to prevent any adverse impact. The assessment shall be made in accordance with BS4142:2014 at the nearest and/or most affected noise sensitive premises, with all machinery for that relevant part of the Phase operating together at maximum capacity. A post installation noise assessment for the relevant part of each Phase shall be carried out where required to confirm compliance with the sound criteria and additional steps to mitigate noise shall be taken, as necessary. Approved details for the relevant part of each Phase shall be implemented prior to occupation of the development and thereafter be permanently retained.

Reason: To ensure that the amenity of occupiers of the development site/ surrounding premises is not adversely affected by noise from plant/mechanical installations/ equipment, in accordance with Policies CC11 and CC13 of the Local Plan 2018.

27. Emergency Generators

Prior to first operational use of any Phase, details shall be submitted to and approved in writing by the Council to confirm that sound emitted by standby or emergency generators relevant to that Phase, during power outages or testing does not exceed the lowest daytime ambient noise level LAeq(15min) as measured or calculated according to BS4142:2014.

Reason: To ensure that the amenity of occupiers of the development site/ surrounding premises is not adversely affected by noise from mechanical installations/ equipment, in accordance with Policies CC11 and CC13 of the Local Plan 2018.

28. Anti- vibration mounts and silencing of machinery etc.

Prior to first operational use of any part of the development within each Phase, machinery, plant or equipment, extract/ ventilation system and ducting forming part of that Phase at the development shall be mounted with proprietary anti-vibration isolators and fan motors shall be vibration isolated from the casing and adequately silenced and maintained as such.

Reason: To ensure that the amenity of occupiers of the development site and surrounding premises is not adversely affected by vibration, in accordance with Policies CC11 and CC13 of the Local Plan 2018.

29. Acoustic lobby where proposals include loud music or voices etc.

Prior to commencement of fit-out works for G-Gate, West Hall and both Hotels, details shall be submitted to and approved in writing by the Council of the installation of acoustic lobbies to entrances and exits which would otherwise allow the emission of internal noise to neighbouring noise sensitive premises.

Reason: To ensure that the amenity of occupiers of the development site/ surrounding premises is not adversely affected by noise, in accordance with Policies CC11 and CC13 of the Local Plan 2018.

30. Sound Insulation of commercial/ industrial building envelope

Prior to commencement of each Phase of the development (excluding Enabling Works), details shall be submitted to and approved in writing by the Council, of sound insulation of the building envelopes within that Phase and other mitigation measures, as appropriate. Details shall demonstrate that noise from uses and activities is contained within the building/ development site and shall not exceed the criteria of BS8233:2014 at neighbouring noise sensitive/ habitable rooms and private external amenity spaces. Approved details for that Phase shall be implemented prior to occupation of the development and thereafter be permanently retained.

Reason: To ensure that the amenity of occupiers of the development site/ surrounding premises is not adversely affected by noise, in accordance with Policies CC11 and CC13 of the Local Plan 2018.

31. Extraction and Odour Control system for non-domestic kitchens

Prior to first operational use of any part of the development within each Phased which is to be used as a commercial kitchen, details shall be submitted to and approved in writing by the Council, of the installation, operation, and maintenance of the odour abatement equipment and extract system for that kitchen, including the height of the extract duct and vertical discharge outlet, in accordance with the 'Guidance on the Control of Odour and Noise from Commercial Kitchen Exhaust Systems' January 2005 by DEFRA. Approved details shall be implemented prior to the commencement of the use of the relevant kitchen and thereafter be permanently retained.

Reason: To ensure that the amenity of occupiers of the development site/ surrounding premises is not adversely affected by cooking odour, in accordance with Policies CC11 and CC13 of the Local Plan 2018.

32. Floodlights, Security lights and Decorative External Lighting

Prior to commencement of each Phase of the development (excluding Enabling Works, Phase 1 and Phase 2), details of external artificial lighting shall be submitted to and approved in writing by the Council. Lighting contours shall be submitted to demonstrate that the vertical illumination of neighbouring premises is in accordance with the recommendations of the Institution of Lighting Professionals in the 'Guidance Notes For The Reduction Of Light Pollution 2011'. Details should also be submitted for approval of measures to minimise use of lighting and prevent glare and sky glow by correctly using, locating, aiming and shielding luminaires. Approved details shall be implemented prior to occupation of the development and thereafter be permanently retained.

Reason: To ensure that the amenity of occupiers of surrounding premises is not adversely affected by lighting, in accordance with Policies CC12 of the Local Plan 2018.

33. Lights off

Prior to first occupation of the office use, a scheme for the control and operation of the proposed lighting within the office buildings, during periods of limited or non-occupation, shall be submitted to and approved in writing by the Council. Details shall be implemented prior to the occupation of the relevant Phase and operated only in accordance with the approved details.

Reason: To ensure that the building does not cause excessive light pollution and to conserve energy when they are not occupied, in accordance with Policy CC12 of the Local Plan 2018.

34. Combustion Plant compliance with Emission Standards

Prior to the first occupation of the development hereby permitted, a report with details of the combustion plant in order to mitigate air pollution shall be submitted to and approved in writing by the council. The report shall include the following:

- a) Details to demonstrate that the termination height of the shared Flue stack for the CHP plant, Ultra Low NOx Gas fired Boiler plant, and Emergency Diesel Generator Plant has been installed at a height to be agreed with Council.
- b) Details to demonstrate that all the CHP Plant, Ultra Low NOx Gas fired boilers, Emergency diesel Generator Plant and associated abatement technologies shall

meet a minimum dry NO_x emissions standard of 25 mg/Nm⁻³ (at 5% O₂), 30 mg/kWh (at 0% O₂) and 95 mg/Nm⁻³ (at 5% O₂) respectively.

- c) Details of emissions certificates, and the results of NO_x emissions testing of each CHP unit, Ultra Low NO_x gas boiler and Emergency Diesel Generator Plant by an accredited laboratory shall be provided to verify the relevant emissions standards in part b) have been met following installation. Where any combustion plant does not meet the relevant emissions Standards in part b) above, it should not be operated without the fitting of suitable secondary NO_x abatement Equipment or technology as determined by a specialist to ensure comparable emissions.
- d) Details to demonstrate where secondary abatement is used for the Emergency Diesel Generator the relevant emissions standard in part b) is met within 5 minutes of the generator commencing operation. During the operation of the emergency Diesel generators there must be no persistent visible emission. The maintenance and cleaning of the systems shall be undertaken regularly in accordance with manufacturer specifications. The diesel fuelled generators shall only be used for a maximum of 48 hours when there is a sustained interruption in the mains power supply to the site, and the testing of these diesel generators shall not exceed a maximum of 12 hours per calendar year.

After the first full year of occupation of the completed development the results of NO_x emissions testing of the combustion plant by an accredited laboratory shall be provided and thereafter on an annual basis to the council to verify compliance of the relevant emissions standards in part b). Approved details shall be fully implemented prior to the occupation/use of the development and thereafter permanently retained and maintained.

Reason: To comply with the requirements of the NPPF, Policies 7.14a-c of the London Plan, and Policy CC10 of the Local Plan 2018

35. Ventilation Strategy

Prior to commencement of the development (excluding Enabling Works, Phase 1 and Phase 2), a Ventilation Strategy report in order to mitigate air pollution shall be submitted to and approved in writing by the Council. The Ventilation Strategy report should include the following information:

- a) Details and locations of the air intake locations at roof level on the rear elevations for units within Use Classes B1, and C1 class use
- b) Details and locations of air extract locations for units within Use Classes B1, C1 and D1 use to demonstrate that they are located a minimum of 2 metres away from the fresh air intakes
- c) Details and locations of air intakes locations for units within Use Classes D1 class use on the rear elevations
- d) Details of the independently tested mechanical ventilation system with NO_x, PM_{2.5}, PM₁₀ filtration for B1 and, C1 use. The NO₂ filtration system shall have a minimum efficiency of 90% in the removal of Nitrogen Oxides/Dioxides, PM_{2.5} and PM₁₀ in accordance with BS EN ISO 10121-1:2014 and BS EN ISO 16890:2016.

The whole Ventilation Strategy shall be designed to prevent summer overheating and minimise energy usage. Chimney/boiler flues and ventilation extracts shall be positioned a suitable distance away from ventilation intakes, openable windows, balconies, roof gardens, terraces, and receptors. The maintenance and cleaning of the systems shall be undertaken regularly in accordance with manufacturer specifications, and shall be the responsibility of the primary owner of the property. Approved details shall be fully implemented prior to the occupation/use of the development and thereafter permanently retained and maintained

Reason: To comply with the requirements of the NPPF, Policies 7.14a-c of the London Plan and Policy CC10 of the Local Plan 2018.

36. Low Emissions Strategy

Prior to occupation of the development hereby permitted a Low Emission Strategy for the operational Phase in order to mitigate air pollution shall be submitted to and approved in writing by the Council. The Low Emission Strategy must detail the remedial action and mitigation measures that will be implemented to protect receptors (e.g. abatement technology for energy plant, design solutions). This Strategy must make a commitment to implement the mitigation measures (including NOx emissions standards for the chosen energy plant) that are required to reduce the exposure of future residents to poor air quality and to help mitigate the development's air pollution impacts, in particular the emissions of NOx and particulates from on-site and off-site transport via a Ultra Low Emission Vehicle Plan (ULEVP) e.g. use of on-road Ultra Low Emission Vehicles in accordance with the emissions hierarchy (1) Electric Vehicle (Zero emission), (2) Hybrid (non-plug in) Electric Vehicle (HEV), (3) Plug-in Hybrid Electric Vehicle (PHEV), (4) Alternative Fuel e.g. CNG, LPG, (5) Petrol and energy generation sources.. Approved details shall be fully implemented prior to the occupation/use of the development and thereafter permanently retained and maintained.

Reason: To comply with the requirements of the NPPF, Policies 7.14a-c of the London Plan, and Policy CC10 of the Local Plan 2018

37. Air Quality Dust Management Plan

Prior to the commencement of each Phase of development (excluding Enabling Works) of the development hereby permitted, an Air Quality Dust Management Plan (AQDMP) in order to mitigate air pollution shall be submitted to and approved in writing by the council. The AQDMP must include an Air Quality Dust Risk Assessment (AQDRA) that considers sensitive receptors off-site of the development and is undertaken in compliance with the methodology contained within Chapter 4 of the Mayor of London 'The Control of Dust and Emissions during Construction and Demolition', SPG, July 2014 and the identified measures recommended for inclusion into the AQDMP. The AQDMP submitted must comply with the Mayor's SPG and should include: Inventory and Timetable of dust generating activities during demolition and construction; Site Specific Dust mitigation and Emission control measures in the table format as contained within Appendix 7 of Mayor's SPG including for on-road and off-road construction traffic; Detailed list of Non-Road Mobile Machinery (NRMM) used on the site. The NRMM should meet as minimum the Stage IV emission criteria of Directive 97/68/EC and its subsequent amendments. This will apply to both variable and constant speed engines for both NOx and PM. An inventory of all NRMM must be registered on the NRMM register <https://nrmm.london/user-nrmm/register>; Ultra Low Emission Vehicle Strategy

(ULEVS) for the use of on-road Ultra Low Emission Vehicles in accordance with the emission hierarchy (1) Electric (2) Hybrid (Electric-Petrol) (3) Alternative Fuel e.g CNG, LPG (4) Petrol, (5) Hybrid (Electric-Diesel) (6) Diesel (Euro 6 & Euro VI); Details of Air quality monitoring of PM10 where appropriate and used to prevent levels exceeding predetermined Air Quality threshold trigger levels. Developers must ensure that on-site contractors follow best practicable means to minimise dust and emissions at all times. Approved details shall be fully implemented and permanently retained and maintained during the demolition and construction Phases of the development.

Reason: To comply with the requirements of the NPPF, Policies 7.14a-c of the London Plan, and Policy CC10 of the Local Plan 2018

38. Green Infrastructure

Prior to the commencement of each Phase of the development hereby permitted (excluding Enabling Works and Phase 1), details of the construction of green infrastructure forming part of that Phase (including details of planting species and maintenance) in order to mitigate air pollution shall be submitted to and approved in writing by the Council. The green infrastructure shall be constructed and planted on the developments site boundaries with Hammersmith Road (A315), Blythe Road, Beaconsfield Terrace Road, and Maclise Road in full accordance with the Phytosensor Toolkit, Citizen Science, May 2018 and the 'First Steps in Urban Air Quality', TDAG, 2017 guidance documents within the first available planting season following completion of the development. Any plants which die, are removed, become seriously damaged and diseased within a period of five years from completion of the requisite part of the development shall be replaced in the next planting season with others of similar size and species. Approved details shall be fully implemented prior to the occupation/use of that part of the development and thereafter permanently retained and maintained.

Reason: To comply with the requirements of the NPPF, Policies 7.14a-c of the London Plan, and Policy CC10 of the Local Plan 2018

39. External seating areas

No ground level external seating areas shall be permitted without written approval from the Council, for A1-A4 class use and public amenity use within a minimum of 10 m of the kerbside on Hammersmith Road (A315), Maclise Road and Blythe Road.

Reason: To in order to mitigate air pollution and comply with the requirements of the NPPF, Policies 7.14a-c of the London Plan, and Policy CC10 of the Local Plan 2018

40. Micro Climate

Prior to commencement (excluding Enabling Works and Phase 1), details of micro climate mitigation measures necessary to provide an appropriate wind environment throughout and surrounding the development shall be submitted to and approved in writing by the Council. Approved details for each Phase shall be implemented, and permanently retained thereafter.

Reason: To ensure that suitable measures are incorporated to mitigate potential adverse wind environments arising from the development, in accordance with Policies 7.6 and 7.7 of the London Plan.

41. Ecological Management Plan

Prior to practical completion of the development, an Ecological Management Plan shall be submitted to and approved in writing by the Council. The EMP shall comprise a habitat management plan and monitoring report which shall set out objectives and prescriptions for the management of new areas of vegetation and public open spaces within the development, for a minimum period of 5 years.

To ensure the biodiversity of the site is protected and enhanced where possible, in accordance with policy 7.19 of the London Plan and Policies CC2, DC1, DC8, OS2, OS4 and OS5 of the Local Plan 2018.

42. Waste Network

The development shall not be occupied until confirmation has been submitted to and approved in writing by Council in consultation with Thames Water, that either: - all combined water network upgrades required to accommodate the additional flows from the development have been completed; or – an infrastructure phasing plan has been agreed with Thames Water to allow additional properties to be occupied. Where a housing and infrastructure phasing plan is agreed no occupation shall take place other than in accordance with the agreed infrastructure phasing plan.

Reason: The development may lead to sewage flooding and network reinforcement works are anticipated to be necessary to ensure that sufficient capacity is made available to accommodate additional flows anticipated from the new development. Any necessary reinforcement works will be necessary in order to avoid sewer flooding and/or potential pollution incidents.” The developer can request information to support the discharge of this condition by visiting the Thames Water website at thameswater.co.uk/preplanning. Should the Council consider the above recommendation inappropriate or are unable to include it in the decision notice, it is important that the Council liaises with Thames Water Development Planning Department (telephone 0203 577 9998) prior to the planning application approval.

43. Water Network

The development shall not be occupied until confirmation has been submitted to and approved in writing by Council in consultation with Thames Water, that either: - all water network upgrades required to accommodate the additional flows from the development have been completed; or – an infrastructure phasing plan has been agreed with Thames Water to allow additional properties to be occupied. Where a housing and infrastructure phasing plan is agreed no occupation shall take place other than in accordance with the agreed infrastructure phasing plan.

Reason: The development may lead to no / low water pressure and network reinforcement works are anticipated to be necessary to ensure that sufficient capacity is made available to accommodate additional demand anticipated from the new development” The developer can request information to support the discharge of this condition by visiting the Thames Water website at thameswater.co.uk/preplanning. Should the Council consider the above recommendation inappropriate or are unable to include it in the decision notice, it is important that the Council liaises with Thames

Water Development Planning Department (telephone 0203 577 9998) prior to the planning application approval.

44. Event Traffic Management Plan

Prior to first occupation of Phase 3 a detailed Event Traffic Management Plan shall be submitted to and approved in writing by LBHF subject to consultation with TfL. The document should include event set-up, event day and event break down traffic management. This document will be subject to ongoing revision/ updates in conjunction with H&F Highways and TfL.

Reason: To ensure that the site has adequate management arrangements are in place to control traffic and minimise disruption to the network with Policies 5.2, 5.18, 5.19, 5.21, 6.3, 7.14 and 7.15 of the London Plan, Policies CC1, CC2, CC6, CC7, CC9, CC10, CC11, CC12, CC13, T1 and T6 of the Local Plan 2018 and SPD Transport Policies of the Planning Guidance Supplementary Planning Document 2018.

45. Site Wide Traffic Management Plan

Prior to occupation of any use (except for the exhibition D1 use), a site wide Traffic Management Plan shall be submitted to and approved in writing by the Council subject to consultation with TFL.

Reason: To ensure that the site has adequate management arrangements are in place to control traffic and minimise disruption to the network with Policies 5.2, 5.18, 5.19, 5.21, 6.3, 7.14 and 7.15 of the London Plan, Policies CC1, CC2, CC6, CC7, CC9, CC10, CC11, CC12, CC13, T1 and T6 of the Local Plan 2018 and SPD Transport Policies of the Planning Guidance Supplementary Planning Document 2018.

46. Cycle Management Plan

Prior to first occupation of the development, a Cycle Parking Management Plan shall be submitted to and approved in writing by the Council. This management plan shall include details of access to cycle parking and how any potential conflicts with vehicles will be resolved or managed. The development shall not be operated otherwise than in accordance with the Cycle Parking Management Plan as approved and shall thereafter be permanently retained in this form.

Reason: To ensure an appropriate level, mix and location of cycle parking is achieved for the development and that management arrangements are in place to control its allocation and use in accordance with Policies 5.2, 5.18, 5.19, 5.21, 6.3, 7.14 and 7.15 of the London Plan, Policies CC1, CC2, CC6, CC7, CC9, CC10, CC11, CC12, CC13, T1 and T6 of the Local Plan 2018 and SPD Transport Policies of the Planning Guidance Supplementary Planning Document 2018.

47. Cycle Parking

Prior to commencement of each Phase of development (excluding Enabling Works and Phase 1), details of the facilities to be provided for the secure storage of bicycles for each use within that Phase, shall be submitted to and approved in writing by the Council. Such details shall include the number, location and access arrangements to cycle parking. Prior to occupation the relevant approved facilities will be provided. The cycle

parking facilities shall thereafter be retained and not used for any other purpose without the prior written consent of the Council.

Reason: To ensure the suitable provision of cycle parking within the Development to meet the needs of future site occupiers and users and in the interest of the appearance of the development, in accordance with Policies 6.9 and 6.13 of the London Plan and Policy T3 of the Local Plan 2018.

48. Vehicular Parking

Prior to commencement of Phase 2, the detailed design, access, layout and location of the car parking provided shall be submitted to and approved in writing by the Council. The proposed car parking shall accord with the details as approved and shall be retained permanently thereafter.

Reason: To ensure that the detailed design of the access ramps provides sufficient vertical clearance and capacity for vehicle manoeuvring in the interest of public safety and to ensure that the detailed design of the roads, footways and cycleways would avoid vehicle/pedestrian conflict in accordance with Policy T1, T4 and T5 of the Local Plan 2018.

49. Electric Vehicle Charging Point

Prior to first occupation of Phase 2 of the development hereby permitted, details of the installation including location and type of active electric vehicle charging points within the car parking area must be submitted to and approved in writing by the Council. The electric vehicle charging points comprising at least 20% of the total number of car parking spaces provided shall be active electric vehicle charging points; a further 80% of the total number of car parking spaces provided shall be passive. The approved electric vehicle charging points shall be installed and retained in working order for the lifetime of the development. The uptake of the active electric vehicle charging points will be regularly monitored via the Travel Plan and if required a further 20% active provision will be made available.

Reason: To encourage sustainable travel in accordance with policies 5.8, 6.13 and 7.2 of the London Plan, Policies T1, T2 and T4 of the Local Plan 2018

50. Delivery and Servicing Management Plan

Prior to first occupation of the relevant part of each Phase, a Delivery and Servicing Management Plan (DSMP) for that Phase, including vehicle tracking where required, shall be submitted to and approved in writing by the Council. The DSMP for the relevant part of each Phase shall detail the management of deliveries, emergency access, collection of waste and recyclables, times and frequencies of deliveries and collections/ silent reversing methods/ location of loading bays and vehicle movement in respect of the relevant Phase. The approved measures for the relevant part of each Phase shall be implemented and thereafter retained for the lifetime of the residential or commercial uses in the relevant part of the site.

Reason: To ensure that satisfactory provision is made for refuse storage and collection and to ensure that the amenity of occupiers of the development site and surrounding premises is not adversely affected by noise, in accordance with Policy 6.11 of the

London Plan and Policies T2, CC11 and CC13 of the Local Plan 2018 and SPD Key Principle TR28 (2018).

51. Waste Management Strategy

Prior to commencement of Phase 2, a Waste Management Strategy shall be submitted and approved in writing by the Council. Details shall include refuse arrangements including storage, collection, and recycling for all uses within each Phase and how recycling will be maximised and be incorporated into the facilities of the development. All approved storage arrangements shall be provided in accordance with the approved details and shall be permanently retained thereafter in accordance with the approved details and shall thereafter be permanently retained in this form.

Reason: To protect the environment and to ensure that satisfactory provision is made for refuse/recycling storage and collection, in accordance with policy 5.17 and 5.3 of the London Plan and Policies CC6 and CC7 of the Local Plan 2018 and SPD Key Principle WM1 2018.

52. Healthy Streets

Prior to completion of Phase 2, a Healthy Streets assessment shall be submitted to and approved in writing by the Council in consultation with Transport for London. The measures within the approved Healthy Streets assessment shall be implemented prior to first occupation within Phase 2, and thereafter permanently retained in this form.

Reason: To comply with the Mayors Transport Strategy.

53. Use of Buildings

The following buildings shall be restricted to the use classes as shown on the approved drawings and as outlined below:

Grand Hall – D1, A3/A4
National Hall – D1, C1, A1/A2/A3/A4
Central – D1, B1, A1/A2/A3/A4
G-Gate – Theatre use (Sui Gen), D1, A1/A2/A3/A4
West Hall – D1/D2
MSCP – D1/D2, B1, C1
Pillar Hall – A3/A4
Level 2 – A1/A2/A3/A4

Reason: To ensure the development is carried out and used in accordance with the impacts assessed in the Environmental Impact Assessment, in accordance with Policies 7.1, 7.2, 7.3, 7.4, 7.5, 7.6, 7.7 and 7.8 of the London Plan and Policies DC1, E1, and TLC1 of the Local Plan 2018.

54. Maximum Floor Space Areas

The total gross internal floor space (GIA) areas of the retail (Class A1) and office space (Class B1) comprising the development hereby approved shall not exceed:

- (i) Class A1 - 600 sqm gross internal area (GIA).

(ii) Class B1 - 63,206 sqm gross internal area (GIA).

Reason: To ensure the development carried out does not exceed the maximum floor space in accordance with the approved plans and the quantum of floor space keeps within the development approved and assessed in the Environmental Impact Assessment, in accordance with Policies 7.1, 7.2, 7.3, 7.4, 7.5, 7.6, 7.7 and 7.8 of the London Plan and Policies DC1, E1, and TLC1 of the Local Plan 2018.

55. Hours of Operation

The hours of operation for all uses approved are 7am to 12am daily, except as follows;

Live Music/ Entertainment Venue: 8am to 11pm daily

Class A Uses: 7am to 11:30pm daily

Level 2: 7am to 12am

Reason: To ensure that the use does not result in loss of amenity to neighbouring residents in terms of noise and disturbance, in accordance with Policies T1, CC11, CC12, and CC13 of the Local Plan 2018.

56. Operational Management Plan

Prior to first occupation of each relevant Phase (excluding Enabling Works and Phase 1) of the development hereby approved, an Operational Management Plan shall be submitted to and approved in writing by the Council. The Operational Management Plan shall include details of hours of operation for the different permitted uses, including details relating to the operational hours of Level 2. The development shall be implemented in accordance with the approved details prior to occupation and shall thereafter be permanently retained in this form.

Reason: To ensure that the amenities of surrounding occupiers are not unduly affected by noise and other disturbances, in accordance with Policies T1, CC11, CC12, and CC13 of the Local Plan 2018.

57. Materials

Prior to the commencement of the relevant part of each Phase of the development (excluding Enabling Works), details and samples of all the materials to be used in all external faces and roofs of the buildings to include entrances, cladding, fenestration, roofing and plant, shall be submitted to and approved in writing by Council. External material sample panels, including samples of brickwork, stonework, concrete, pointing style, mortar colour and mix shall be erected onsite for the inspection by Council's Conservation Officer and written approval by Council. The development shall be carried out in accordance with the details as approved and thereafter permanently retained in this form.

Reason: To ensure a satisfactory external appearance and to prevent harm to the street scene and public realm, in accordance with Policies 7.1 and 7.6 of the London Plan and Policies DC1, DC2 and DC8 of the Local Plan 2018.

58. 1:20

Prior to the commencement of the relevant part of each Phase of the development (excluding Enabling Works), detailed drawings at a scale not less than 1:20 (in plan, section, and elevation) of typical bays and junctions with adjacent buildings of each elevation of each building shall be submitted to and approved in writing by the Council. This shall include detailed drawings at of scale of not less than 1:20 (in plan, section and elevation) of shopfronts for any A Class uses on site. The development shall be carried out in accordance with the details as approved and thereafter permanently retained in this form.

Reason: To ensure a satisfactory external appearance and to prevent harm to the street scene and public realm, in accordance with Policies 7.1 and 7.6 of the London Plan and Policies DC1, DC2 and DC8 of the Local Plan 2018.

59. Flue Design

Prior to commencement of development Phase 1, the following details in relation to the flue hereby consented in L Yard shall be submitted to and approved in writing by the Council:

- detailed drawings at a scale of not less than 1:20 (in plan, section and elevation) of a typical part of the elevation of the flue;
- details and samples of the external materials of the flue.

The development shall be carried out in accordance with the details as approved and thereafter permanently retained in this form.

Reason: To ensure a satisfactory external appearance and to prevent harm to the street scene and public realm, in accordance with Policies 7.1 and 7.6 of the London Plan and Policies DC1, DC2 and DC8 of the Local Plan 2018.

60. Landscaping & Public Realm

Prior to commencement of Phase 2 hereby permitted, details of the proposed soft and hard landscaping of all areas external to the buildings shall be submitted to and approved in writing by the Council. These details will include the public realm within Level 2 (including detailed drawings of the canopy and escalators), and any public realm provided along Hammersmith Road, Olympia Way, Blythe Road, Beaconsfield Terrace Road and Lyons Walk. The details shall include: planting schedules and details of the species, height and maturity of any trees and shrubs, including sections through the planting areas; depth of tree pits, containers and shrub beds; details relating to: the access of each building, pedestrian surfaces, materials, kerb details, external steps and seating, street furniture, bins and lighting columns that shall all ensure a safe and convenient environment for blind and partially sighted people. The landscaping works shall be carried out in accordance with the approved details and shall thereafter be permanently retained in this form.

Reason: To ensure a satisfactory external appearance of the development and relationship with its surroundings, and the needs of the visually impaired are catered for in accordance with the Equality Act 2010, Policies 3.1, 7.1 and 7.6 of the London Plan, and Policies DC1, DC8, OS2 and OS5 of the Local Plan 2018.

61. Samples Hard landscaping and Canopy

Prior to the commencement of Phase 2, details and samples of all the materials to be used for any hard landscaping, street furniture and the public realm canopy shall be submitted to and approved in writing by the Council. The development shall be carried out in accordance with the details as approved and thereafter permanently retained in this form.

Reason: To ensure a satisfactory external appearance and to prevent harm to the street scene and public realm, in accordance with Policies 7.1 and 7.6 of the London Plan and Policies DC1, DC2 and DC8 of the Local Plan 2018.

62. Landscape & Public Realm maintenance

Prior to commencement of landscaping and public realm works, a Landscape & Public Realm Management Plan shall be submitted to and approved in writing by the Council for all of the landscaped areas. This shall include details of management responsibilities and maintenance schedules for all landscape areas. The landscape management plan shall be implemented in accordance with the approved details and shall thereafter be permanently retained in this form.

Reason: To ensure that the development provides an attractive natural and visual environment in accordance with Policies 7.1 and 7.6 of the London Plan, and Policies DC1, DC8, OS2 and OS5 of the Local Plan 2018.

63. Site Wayfinding

Prior to practical completion details of wayfinding and signage proposed around and on the site should be submitted to and approved in writing by Council. The wayfinding and signage proposed on and around the site should then be provided as approved and thereafter be permanently retained in this form.

Reason: To ensure that the Council may be satisfied with the detail of the proposed wayfinding to ensure a satisfactory appearance and ensure access for all in accordance with Policies DC1 and DC8 of the Local Plan 2018.

64. Obscured Glass

The window glass at ground level in the development, including the shop fronts shall be clear and shall not be mirrored, painted or otherwise obscured and shall be permanently retained as such unless clearly indicated on approved drawings or subsequently agreed with the Council in writing.

Reason: To ensure a satisfactory external appearance and to prevent harm to the street scene and public realm, in accordance with Policy 7.6 of The London Plan, and Policies DC1 and DC8 of the Local Plan 2018.

65. Solar glare

Prior to the commencement of development Phase 3, a solar glare study shall be submitted to and approved in writing by the Council. All development pursuant to this permission shall be carried out in accordance with the approved details.

Reason: To ensure a satisfactory external appearance and to prevent harm to the street scene and public realm, in accordance with Policy 7.6 of The London Plan, and Policies DC1 and DC8 of the Local Plan 2018.

66. Occupiers Signage Strategy

Prior to the first occupation of each Phase of the development, an Occupier Signage Strategy for all uses within that Phase shall be submitted to and approved in writing by the Council and all development pursuant to this permission shall be carried out in accordance with the approved details.

Reason: To ensure that the Council may be satisfied with the detail of the proposed development and to ensure a satisfactory external appearance in accordance with Policies DC1 and DC8 of the Local Plan 2018.

67. Window Cleaning Equipment

Prior to first use or occupation of the development within each Phase of development, details of the proposed window cleaning equipment for the buildings within that Phase shall be submitted and approved in writing by the Council. The details shall include the appearance, means of operation and storage of the cleaning equipment. No part of the development within the relevant Phase shall be used or occupied until the equipment has been installed in accordance with the approved details and shall thereafter be permanently retained in this form.

Reason: To ensure a satisfactory external appearance and to prevent harm to the street scene and public realm, in accordance with Policies 7.1 and 7.6 of the London Plan, and Policies DC1 and DC8 of the Local Plan 2018.

68. Access Management Plan

Prior to first occupation of each Phase of development, an Inclusive Access Management Plan for that Phase shall be submitted to and approved in writing by the Council. The plan will include details of access, wheelchair accessible provision for exhibition spaces, hotel, restaurant, offices and entertainment venues, and facilities to accommodate hearing and sight impairments at entertainment venues. The plan should set out a strategy for ongoing consultation with specific interest groups with regard to accessibility of the relevant part of the site. On-going consultation shall then be carried out in accordance with the approved IAMP. The development shall not be operated otherwise than in accordance with the Inclusive Access Management Plan as approved and thereafter be permanently retained in this form.

Reason: To ensure that the proposal provides an inclusive and accessible environment in accordance with the Policy 7.2 of the London Plan and Policy E3 of the Local Plan 2018.

69. Level Threshold

The ground floor entrance doors to the proposed buildings and integral lift/stair cores shall not be less than 1-metre-wide and the threshold shall be at the same level as the adjoining ground level fronting the entrances to ensure level access.

Reason: To ensure the development provides ease of access for all users, in accordance with Policy 3.1 and 7.2 of the London Plan, and Policy DC1 and HO6 of the Local Plan 2018.

70. Lifts

Prior to first occupation and/or use of each relevant building, details of fire rated lifts in each of the buildings submitted to and approved in writing by the Council. Details shall include loading lifts to the basement levels and the measures to ensure that no wheelchair occupiers are trapped if a lift breaks down. The fire rated lifts shall be installed as approved and maintained in full working order for the lifetime of the development.

Reason: To ensure that the development provides for the changing circumstances of occupiers and responds to the needs of people with disabilities, in accordance with policies 3.8 and 7.2 of the London Plan, and Policy DC1 and HO6 of the Local Plan 2018.

71. Hotel – Wheelchair Standards

A minimum of 10% of all hotel bedrooms hereby approved shall be capable of meeting the needs of wheelchair users and shall be designed and capable of adaptation. This arrangement shall thereafter be permanently retained.

Reason: To ensure the provision and retention of facilities for all, including disabled people, in accordance with Policy 4.5 of the London Plan and Policies DC1 and HO6 of the Local Plan 2018.

72. Hotel bed Cap

The maximum number of hotel rooms in each hotel component of the site shall be capped as follows:

National – 123 rooms

MSCP – 211 rooms

Reason: In the interest in maintaining the quality of the hotels both externally and internally and to control the intensity of use of the listed buildings in order to preserve their special architectural and historic interest in accordance with Policy DC1, DC2 and DC8 of the Local Plan 2018.

73. Replacement of Trees, Shrubs and Planting

Any trees, shrubs or planting including works associated with green roofs or wall boundary planting pursuant to the soft landscape details that is removed, or seriously damaged, dying or diseased within five years of the date of planting shall be replaced in the next planting season with a similar size and species to that originally required to be planted.

Reason: To ensure a satisfactory external appearance in terms of the provision of tree and shrub planting, in accordance with Policies 7.1 and 7.6 of the London Plan, and Policies DC1, DC8, OS2 and OS5 of the Local Plan 2018.

74. Class B1 (office)

The Class B1 (office) use hereby permitted shall be used only and for no other purpose including any other purpose within Class B1 in accordance with the Town and Country Planning (Use Classes Order) 1987 (as amended), or any subsequent Order, or in any provision equivalent to that Class in any statutory instrument revoking and re-enacting that Order with or without modification.

Reason: In granting this permission, the Council has had regard to the circumstances of the case. The conversion of the approved new office accommodation to residential purposes could raise materially different planning considerations and the Council wishes to have an opportunity to consider such circumstances at that time, and to ensure the uses are compatible with the adjoining land uses and to ensure that the amenity of occupiers residing in surrounding residential properties would be safeguarded in accordance with Policies CF3, DC1, DC2, DC7, DC8, E1, HO11, T1, T2, TLC3, TLC5 of the Local Plan 2018 and Key Principles of the Planning Guidance SPD 2018.

75. Telecommunications Equipment (siting and details)

Notwithstanding the provisions of the Town and Country Planning (General Permitted Development), (England) Order 2015 or any Order revoking or re-enacting that Order with or without modification, no aerials, antennae, satellite dishes or related telecommunications equipment shall be erected on any part of the site, without planning permission first being granted.

Reason: To ensure that the visual impact of telecommunication equipment upon the surrounding area can be considered, in accordance with in accordance with Policies 7.6 and 7.8 of the London Plan, and Policies DC1 and DC8 of the Local Plan 2018.

76. Advertisements

No advertisements shall be displayed on or within any elevation of the Development (including inside windows or on the Olympia Estate), without details of the advertisements having first been submitted to and agreed in writing by the Council.

Reason: In order that any advertisements displayed on the building are assessed in the context of an overall strategy, to ensure a satisfactory external appearance and to preserve the integrity of the design of the building, in accordance with Policies DC1 and DC8 of the Local Plan 2018.

77. External Alterations

No alterations shall be carried out to the external appearance of the Development, including the installation of air-conditioning units, ventilation fans or extraction equipment, plumbing or pipes, other than rainwater pipes not shown on the approved drawings, without planning permission first being obtained. Any such changes shall be carried out in accordance with the approved details.

Reason: To ensure a satisfactory external appearance and to prevent harm to the amenities of the occupiers of neighbouring residential properties, in accordance with Policies DC1 and DC8 of the Local Plan 2018.

78. Roller Shutters

No roller shutters shall be installed on any façade of the Development unless the details have been submitted to and approved in writing by the Council.

Reason: To ensure a satisfactory external appearance and to prevent harm to the street scene and public realm, in accordance with Policies DC1, DC5, and DC8 of the Local Plan 2018.

79. Airwaves Interference Study

Prior to commencement of Phase 3 the following details shall be submitted to and approved in writing by the Council:

- (i) The completion of a Base-Line Airwaves Interference Study (the Base-Line Study) to assess airwave reception within/adjacent to the site; and of required
- (ii) The implementation of a Scheme of Mitigation Works for the purposed of ensuring nil detriment during the [Demolition Works and Construction Works] identified by the Base-Line Study. Such a Scheme of Mitigation Works shall be first submitted to and approved in writing by the Council.

The development shall be implemented in accordance with the approved details prior to occupation and shall thereafter be permanently retained in this form.

Reason: To ensure that the existing airwaves reception is not adversely affected by the proposed development, in accordance with Policy 7.13 of the London Plan, and Policies DC1 and DC8 of the Local Plan 2018.

80. Retail Amalgamation

Prior to first occupation of the relevant part of each Phase and notwithstanding the details on the approved drawings, the layouts of the retail (Class A1) and restaurant (Class A3/A4) uses shall be submitted to and approved in writing by the Local Planning Authority. The development shall be carried out in accordance with the approved details and shall not be amalgamated to create larger units within the development.

Reason: To safeguard the amenities of occupiers of neighbouring residential properties in terms of noise, disturbance, car parking and traffic from noise generating uses, and in the interests of impacts on surrounding local businesses and centres in accordance with Policies TLC1, TLC4, CC11, CC13 and T4 of the Local Plan 2018.

Reason(s) for granting planning permission:

- 1) Principle of Development: The redevelopment of the Olympia Way would deliver a mixed use cultural, employment and visitor attraction, providing economic, cultural, and social benefits. The development would contribute to the local and wider London economy and is supported in land use terms. London Plan Policy 2.1 advocates the Mayor's commitment to ensuring that London retains and extends its global role, Policy 3.16 supports the protection and enhancement of social infrastructure, Policy 3.19 supports the increase or enhance of the provision of sports and recreational facilities and Policy 4.6 the continued success of London's diverse range of arts, cultural, professional sporting and entertainment enterprises and their associated cultural, social, and economic benefits. The proposed

development is therefore considered acceptable in land use terms, subject to the satisfaction of other development plan policies, in accordance with policies 2.13, 2.15, 3.3, 3.4 of the London Plan and Policies E1, E4, CF1, CF2, CF3, HO1, OS1 of the Local Plan (2018).

- 2) **Local Economy and Employment:** The proposal would continue to provide significant employment opportunities both in the borough and London generally. The development would generate an estimated 565 construction related full time equivalent (FTE) jobs per year over the build period and some 4,560-5,045 further FTE jobs once the development is complete and operational. Affordable space comprising 5% of the total eligible Class B1 floorspace would be secured through the s106 agreement. The development would provide modern and upgraded floorspace, and deliver wider benefits by way of increasing local expenditure through increased employment levels, additional visitors through the visit, cultural and leisure uses proposed, and job and job opportunities for residents and companies. The employment and training initiatives secured through the S106 agreement would bring significant benefits to the local area while a local procurement initiative will be entered into by way of the legal agreement to provide support for businesses. Furthermore, contributions through the delivery of tickets for borough residents and engage with local schools and colleges would have a positive effect on the borough. The development is therefore in accordance with Policies 3.1 and 4.12 of the London Plan and policies E1, and E4 of the Local Plan (2018).
- 3) **Design and Heritage:** It is considered that the proposals will deliver good quality architecture which optimises the capacity of the site with good quality good exhibition, hotel, theatre, retail, leisure and commercial accommodation. The development would a new high-quality spaces and public realm. The height, scale and massing of the proposed built form is appropriate and provides a satisfactory design response to the site and surrounding townscape at its edges. The elevations have an architectural character which provides interest across the frontages. The relationship between the built form and public realm would assist in the creation of a sense of place. Where harm has been identified to heritage assets it is considered this is outweighed by the substantial design, heritage and public benefits identified. It is considered that this is compliant with Section 16, 66 and 72 of the Planning (Listed Buildings and Conservation Areas) Act 1990. The proposed development is therefore considered acceptable in accordance with the NPPF, Policies 7.1, 7.2, 7.3, 7.4, 7.5, 7.6 and 7.21 of the London Plan and Policies DC1, DC2, DC4, DC7 and DC8 of the Local Plan (2018).
- 4) **Inclusive Access:** The development will provide a high quality environment for disabled and impaired members of the community and the commitments within the Access Statement are positive and deliverable by way of conditions and reserved matters applications. As such the proposal will comply with Local Plan Policies DC1 and DC2 as well as Planning Guidance SPD Key Principles DA1, DA4, DA5, DA6, DA7, DA8, DA9, DA11, DA12 and DA13.
- 5) **Transport:** It is considered that the overall impact of the proposed development set out in the Transport Statement is acceptable. The proposal will lead to a reduction of on-site parking with the removal of an existing car park with 380 car parking spaces and a new car park with a capacity for up to 181 car parking spaces or 82 large vans. A Site-wide Car Park Management Plan is included and would be

secured within the s106 legal agreement. Funding towards a review of Controlled Parking Zone within the vicinity of the application site and any of the resultant mitigation required would be secured via s106 agreement. Proposed trips generated by car would be mitigated through a car parking management plan. Promotion of sustainable and active travel to and from the site is addressed through various travel plans secured via s106 agreement. Conditions would secure satisfactory provision of cycle parking, construction and demolition logistics and management. Adequate provision for storage and collection of refuse and recyclables would be provided. Further mitigation is secured by provision of upgrades to Kensington Olympia station, West Brompton, London buses, cycle hire docking stations and the temporary layout and future delivery of CS9. A Section 278 agreement is secured to carry out works to the public highway. The proposed development therefore accords with Policies 6.1, 6.3, 6.9, 6.10, 6.11, 6.13 of the London Plan and Policies T1, T2, T3, T4, T5 and T7 of the Local Plan (2018).

- 6) **Impact on Neighbouring Properties:** The proposed development is considered to have an acceptable impact upon the amenities and living conditions within surrounding properties in respect of daylight, sunlight, over-shadowing, overlooking/privacy, noise, and vibration impacts. Although there are recorded incidences whereby the impacts exceed the BRE technical guide for daylight and sunlight, there are very few overall transgressions and the extent of level changes are moderate at worst. With regards to noise and privacy impacts, the proposals are acceptable on the basis that planning conditions are secured to limit the additional impacts to arise out of the development, including those during construction and demolition phases. Potential impacts in terms of air quality, light pollution, noise, or TV/radio reception would be acceptable regarding the various mitigation methods proposed which are secured by condition. In this regard, the development would respect the principles of good neighbourliness. The proposed development is therefore considered to be acceptable and would be in accordance with policies 7.1, 7.6, 7.7 of the London Plan and Policies DC1, DC2, DC8, CC10, CC11, CC12 and CC13 of the Local Plan (2018).
- 7) **Safety and Access:** A condition would ensure the development would provide a safe and secure environment for all users in accordance with London Plan Policy 7.3 and Policy DM G1 of the Development Management Local Plan (2013). The development would result in the provision of an inclusive environment, providing 10% of all units as wheelchair units, level access, minimum of one lift to all upper levels and suitable circulation space. Conditions would ensure the proposal would provide ease of access for all persons, including disabled people. Satisfactory provision is therefore made for users with mobility needs, in accordance with Policy 7.2 of the London Plan and Policy HO6 of the Local Plan (2018).
- 8) **Sustainability and Energy:** The application includes Sustainability, BREEAM and Energy Statements which propose a number of measures to reduce CO2 emissions. The proposal includes proposals for water efficiency, waste management and recycling facilities, use of energy efficiency building materials with low environmental impacts where possible, recycled materials where feasible, inclusion of measures to minimise noise pollution and air quality impacts, flood risk and sustainable drainage measures, sustainable transport measures and biodiversity improvements. The development site will also be registered with the Considerate Constructors Scheme to encourage environmentally and socially considerate ways of working and reduce adverse impacts arising from the

construction process. The development proposes a CHP system. Renewable energy generation is proposed in the form of Air Source Heat Pumps and solar PV Panels. A condition requiring a revised Energy Assessment is included seeking further CO2 reductions. Condition is also included requiring the submission of post construction BREEAM assessments to demonstrate that the “Very Good” and “Excellent” ratings. The proposed development therefore accords with Policies 5.1, 5.2, 5.3, 5.5, 5.6, 5.7, 5.8 of the London Plan and Policies CC1, CC2 and CC7 of the Local Plan (2018).

- 9) Air Quality: There will be an impact on local air quality because of the demolition, construction, and operation of the proposed development. However, inclusion of conditions prior to the commencement of above ground works for each phase of the development are included to mitigate the development. During construction and demolition an Air Quality Dust Management Plan is required by condition which will mitigate the air quality impacts of each phase of the development. The Proposed Development will include one central energy centre on site which will have an air quality impact, however these can be suitably mitigated by siting and design and using appropriate NOx emissions abatement technology to ensure the CHP in the energy centre and other associated plant comply with the strictest emission standards possible; all of which are secured by way of condition. The proposed development therefore accords with London Plan Policy 7.14 and Policy CC10 of the Local Plan (2018).
- 10) Drainage and Flood Risk: The site is in flood zone 3a. A Flood Risk Assessment (FRA) has been submitted which advises standard construction practices to ensure the risk of flooding at the site remains low. A Basement Impact Assessment has been included to ensure that the basement of the multi-storey car park site is suitably detailed design with water-proofing measures and is appropriately secured by way of condition. Sustainable drainage systems would be integrated into the development to cut surface water flows into the communal sewer system. Further information on surface water drainage are secured by condition. The development would therefore be acceptable in accordance with the NPPF (2012), Policies 5.11, 5.12, 5.13, 5.14 and 5.15 of the London Plan and policies CC2, CC3 and CC4 in the Local Plan (2018).
- 11) Land Contamination: Conditions would ensure that the site would be remediated to an appropriate level for the sensitive residential and open space uses. The proposed development therefore accords with Policy 5.21 of the London Plan, Policy CC9 in the Local Plan (2018) and Key principles LC1-6 of the Planning Guidance SPG (2018).
- 12) Microclimate: The development would not result in an unacceptable wind microclimate that would cause harm, discomfort or safety issues to pedestrians or the environment around the buildings. A condition is secured to provide additional mitigation measures through the materials and landscaping. The proposal is considered to comply with Policies 7.6 and 7.7 of the London Plan and Policies DC3 and CC2 of the Local Plan (2018).
- 13) Legal Agreement: Planning obligations to offset the impact of the development and to make the development acceptable in planning terms are secured. Contributions relating to securing the provision of affordable space, community benefits, offsetting highways impacts and public realm works, and local training and

employment opportunities and procurement are secured. The proposed development would therefore mitigate external impacts and would accord with Policy 8.2 of the London Plan and Policy INFRA1 of the Local Plan (2018).

- 14) Environmental Impact Assessment: The Environmental Statement, the subsequent Environmental Statement Addendum and the submitted further information to the Environmental Statement and their various technical assessments together with the consultation responses received from statutory consultees and other stakeholders and parties, enable the Council to determine this application with knowledge of the likely significant environmental impacts of the proposed development.
- 15) Objections: Whilst a large number of issues have been raised by objectors to the scheme it is considered, for the reasons explained in the detailed analysis, that planning permission should be granted for the scheme subject to appropriate safeguards to ensure that necessary controls and mitigation measures are established. This decision is taken on the basis of the proposed controls, mitigation measures and delivery commitments contained in the draft conditions and Heads of Terms for the Section 106 Agreement set out in this committee report, which are considered to provide an adequate framework of control to ensure as far as reasonably practicable that the public benefits of the scheme will be realised in accordance with relevant planning policies whilst providing the mitigation measures and environmental improvements needed to address the likely significant adverse impacts of the development.
- 16) Conditions: In line with the Town and Country Planning Act 1990 and the Town and Country Planning (Pre-commencement Conditions) Regulations 2018, officers have consulted the applicant on the pre-commencement conditions included in the agenda and the applicant has raised no objections.

Officer Report

LOCAL GOVERNMENT ACT 2000 LIST OF BACKGROUND PAPERS

All Background Papers held by case officer named above:

Application form received: 18th September 2018

Drawing Nos: see Condition 2

Policy Documents: National Planning Policy Framework (NPPF) 2018
The London Plan 2016
LBHF - Local Plan 2018
LBHF - Supplementary Planning Document 2018

Consultation Comments: Appendix 1

Neighbour Comments: Appendix 2

1.0 BACKGROUND

- 1.1. This report should be read in together with the application for listed building consent under reference 2018/03101/LBC. Member's should be aware that an outline application for a development comprising commercial units, public realm and alterations including pedestrianisation to Olympia Way is also under consideration under reference 2018/03102/OUT.
- 1.2. Mayoral Referral
- 1.3. Under the terms of the Town & Country Planning (Mayor of London) Order 2008, the Greater London Authority has been notified as the application is within the thresholds of potential strategic importance to London.
- 1.4. The Mayor of London formally considered the proposal on 14th January and issued a Stage 1 report, a summary of which is set out within the Consultations section of this report. The contents of the Stage 1 response have been considered by both the applicant and the council and there have been discussions with the officers of the GLA and TfL to ensure that their concerns and comments have been properly addressed as far as is reasonably practicable.
- 1.5. Should planning permission be granted, this application would be referred to the Mayor of London prior to the issue of any decision notice. The Mayor has a period of 14 days from the date of notification to consider the council's resolution before issuing a decision as to the call-in of the application for the Mayor to act as the local planning authority, or to allow the application to proceed.
- 1.6. **Site and Designations Context**
- 1.7. The Olympia site within this application is some 4.6 hectares and is bound by Hammersmith Road to the south, the western edge of Olympia Way the east, Maclise Road to the north and Beaconsfield Terrace Road and Blythe Road to the west. The western boundary at the currently vacant site known as G-Gate to the south-west corner of the site is bound by a spur road from Blythe Road called Lyons Walk, which also features a pedestrianised area onto Hammersmith Road; it is this part that adjoins the office building at 66 Hammersmith Road to the west. To the east of the site is Olympia Way which forms the borough boundary with the Royal Borough of Kensington and Chelsea and features Kensington Olympia Station, originally built to serve the site and served by Overground and limited District Line trains.
- 1.8. Olympia comprises a series of buildings that together form the site and the overall use:
 - Grand Hall to the east onto Olympia Way. Grade II*.
 - Pillar Hall, to the north of Grand Hall onto Olympia Way; together these form the original buildings. Grade II*.
 - National Hall to the south-east corner onto Olympia Way to the east and Hammersmith Road the south. Grade II.
 - Central Hall to the southern boundary on Hammersmith Road. Grade II.

- Maclise Road Multi-storey Car Park to the north onto Maclise Road. Grade II.
 - G-Gate to the south-west corner onto Hammersmith Road/Lyons Walk and adjoining Central Hall to the east. The site is currently vacant and forms part of the logistics for the site accessed from Blythe Road.
 - West Hall to the west onto Blythe Road.
 - L-Yard to the west onto Blythe Road, the car park adjoins to the north with West Hall to the south. This goes through to the rear of Pillar Hall and forms part of the logistics for the site from Blythe Road.
- 1.9. Grand Hall, National Hall, Central Hall and West Hall form the four exhibition spaces for Olympia and together form almost the entirety of the southern and eastern boundaries. The first two are of similar appearance with large span vaulted glass roofs, Central Hall is later and is of an art deco design from 1923. West Hall provides additional exhibition space and has been significantly rebuilt.
- 1.10. The site is located within the Olympia and Avonmore Conservation Area, as well as the Heathrow Safeguarding Zone. A number of buildings are subject to statutory listing as set out above. Adjoining the site to the north is the Lakeside, Sinclair and Blythe Road Conservation Area, typified by a consistent residential character. To the southern boundary is the Dorcas Estate Conservation Area and the west the Brook Green Conservation Area which features a mixture of residential streets and larger commercial buildings.
- 1.11. The site lies within Flood Zones 1, 2 and 3, an Archaeological Priority Area and within a borough-wide designated Air Quality Management Area (AQMA). The site has a Public Transport Accessibility Level (PTAL) of between 5 and 6a, as well as Kensington Olympia the site is in close proximity to Barons Court and West Kensington underground stations. Bus services operate at multiple stops on Hammersmith Road. The site is not within any key views at a London or local level.
- 1.12. Olympia Way, which is not part of this application and forms part of the proposals under the associated outline application, is not a public highway but does have one way north bound vehicular access onto Maclise Road from Hammersmith Road. Olympia Way is owned by Network Rail with Olympia having a long term leasehold. Maclise Road is one way through to Hazlitt Road to the west, with Sinclair Road being one way southbound onto Maclise Road. Blythe Road is a two way highway which becomes one way westbound to the west to joining Hazlitt Road, and one way southbound from Maclise Road.

Site Context and History

- 1.13. The Olympia site forms its own sub area within the Olympia and Avonmore Conservation Area to the north of Hammersmith Road. The Conservation Area boundaries are tightly drawn around the Olympia site, the former Whiteley's depository at Kensington Village and the highly ornamental residential terraces and later mansion blocks that were developed with the expansion of the London suburbs to west of the West London Railway line along the important route of Hammersmith Road. Many of the buildings in the Conservation Area, including the mansion blocks on the south side of Hammersmith Road facing Olympia, are designated as Buildings of Merit.

- 1.14. The northern side of Hammersmith Road is characterised by a mix of uses involving building types of a larger scale than the buildings and terraces on the southern side of Hammersmith Road. This relationship was established in the beginning of the 20th Century when the Lyons factory complex developed at Cadby Hall, the Post Office Savings Bank Headquarters was built on Blythe Road and the Olympia Exhibition Centre expanded to the south facing Hammersmith Road. Later in the 20th Century large scale mansion blocks and office buildings were built along the north side of Hammersmith Road leading to the town centre, with a general height of up to 8 storeys. The Olympia buildings conform to this general scale of development and provide a prominent frontage to the north side of Hammersmith Road.
- 1.15. The land adjacent to the West London Line has historically included buildings of greater scale and massing than the surrounding residential terraces. The Kensington Village complex to the west of the West London Line and south of the application site is an example of large scale Victorian warehousing now converted to office use, visible from West Cromwell Road on a key radial route into Central London. On the east side of the West London Line in RKBC, the postwar office buildings of Charles House on the south side of Kensington High Street provided significant scale and massing in the townscape. The Charles House site has recently been redeveloped for residential led mix use development and is now known as 375 Kensington High Street. The 12 storey apartment buildings on the Kensington High Street frontage are clearly visible across the railway line in views from the application site. The development also includes a residential tower, set further into the street block, of 17 storeys. To the north of Kensington High Street, on the east side of the West London Line and directly opposite Olympia, former railway land has been redeveloped and incorporates residential blocks of up to 7 storeys.
- 1.16. There are a number of other conservation areas in the vicinity. Dorcas Estate Conservation Area, to the south-west of the site can be seen in close context to Olympia, in particular the Grade II listed terrace at Nos. 99-119 Hammersmith Road on the southern side of the Hammersmith Road that is framed by terraces designated as Buildings of Merit. To the north-west, Olympia shares boundaries with Brook Green and Lakeside/Sinclair/Blythe Road Conservation Areas. The former includes the imposing Blythe House, a multi-winged late Victorian/early 20th Century development listed in part at Grade II, and the latter includes a Victorian townscape of densely populated terraces opposite Olympia's multi-storey car park. On these north-western boundaries, Olympia's buildings largely follow the streets and are in close proximity to their neighbours, but there is a perceived lack of interaction between opposite frontages, due to the inactive frontages of the Olympia buildings.
- 1.17. Despite the close proximity with the diverse residential and commercial neighbourhood, the group of exhibition halls and associated structures clearly stands out from its townscape context due to the building typology and associated façade treatments as well as the greater height and scale of the buildings. The large scale of the barrel-vaulted roofs of the Grand Hall and National Hall are evident in views of the eastern elevation of the site from Olympia Way, Addison Bridge and from within RBKC. The scale of the Grand Hall barrel-vaulted roof is also highly visible from Blythe Road, Beaconsfield

Terrace Road and Sinclair Road. The east elevation is the historic main frontage, as most people would have arrived by train at Kensington Olympia Station. The primary and secondary frontages of the site are clearly legible, and the Olympia buildings have a landmark status in the surrounding townscape. Olympia clearly forms a historically evolved, unique part of the townscape, albeit one that could be better integrated, animated and utilised.

History and development of the exhibition function

- 1.18. Before its development the site was part of the market gardens located just outside London to serve its population with fresh produce. Due to its location alongside the expanding railway and Kensington Olympia Station, as well as on one of the major roads leading into London, the easily accessible site was chosen in the early 1880s to host the National Agricultural Hall, a larger version of the Royal Agricultural Hall in Islington.
- 1.19. The Grand Hall opened on Boxing Day in 1886, with an opening show from the Paris Hippodrome Company. At its opening, Olympia was the largest uninterrupted floorspace in the country and could seat up to 9000 people. The Grand Hall incorporates a gallery at first floor level and function rooms front Olympia Way. The adjacent Pillar Hall provided an ancillary entertainment and hospitality venue with two large halls stacked on top of one another. The pillared hall itself is at upper ground floor level and connected to Grand Hall by a link bridge, the upper hall at first floor level has the characteristics of a music hall, with a gallery and proscenium and was used for early displays of cinematography.
- 1.20. The use of the hall as the largest venue in England expanded quickly beyond the staging of agricultural or military shows to include exhibitions, tournaments, sporting competitions and entertainments of various kinds. Before subsequent phases of Olympia and nearby houses were constructed, pleasure gardens were laid out on the undeveloped areas of the original site, for events and promenading during the summer months, emphasising Olympia as an entertainment destination and not just a functional space for one-off events.
- 1.21. The second phase of Olympia, The National Hall, was built in 1923 on the site of a detached house and three pairs of semi-detached houses at the eastern half of West Kensington Gardens and opened in time for the Ideal Home Exhibition in March 1923. It complemented the original building with a smaller scale hall, function rooms, offices, kitchen and storage rooms as well as a substantial new restaurant space at ground floor level facing Hammersmith Road. The spaces in the National Hall were designed to enable internal links with the Grand Hall on both the main floor and gallery levels if required.
- 1.22. By 1937, a major new hall, the Empire Hall, and the multi-storey car park were completed by Emberton in the style of the modern movement in architecture. Functionally the Empire Hall, now known as Olympia Central, was the first four storey exhibition building ever erected in the country, with the aim to provide a maximum of new exhibition floorspace, quite unlike the vast barrel vaulted spaces at Grand Hall and National Hall.

- 1.23. After both World Wars, during which Olympia was mainly used as a temporary camp for prisoners of war, the buildings went back into use for major tournaments, shows, concerts and exhibitions, e.g. the Ideal Home exhibition that it still hosts today.
- 1.24. During the latter half of the 20th Century until the present day, Olympia has remained a popular venue and it retains an important role in the cultural life of the nation. Olympia is the only surviving major exhibition centre in Central London and makes a valuable contribution to London's economy and status as a World City.

1.25. **Planning History**

- 1.26. The site has a long planning history, the most relevant of which is considered to be as follows:

G-Gate

- 1.27. 2013/03806/FUL – Permission granted 2nd July 2014 for the erection of a part 7 and part 9 storey hotel building (Class C1) providing 242 bedrooms with ancillary uses, including a restaurant and bar at first floor level and café at ground floor level to Hammersmith Road, following demolition of the existing boundary treatments on the site; creation of a taxi-drop off facility and landscaping on Lyons Walk. A ground level marshalling yard for use by Olympia Exhibition Centre would be retained and internal pedestrian links to the Olympia Central and West Hall buildings of Olympia Exhibition Centre would be created. Associated Listed Building Consent under ref. 2013/03807/LBC granted for alteration and part removal of the west façade of Central Hall.
- 1.28. 2008/00547/FUL – Permission granted 17th August 2010 for the erection of a part 7, part 9 and part 10 storey building over a ground level marshalling yard for Olympia Exhibition Centre, to provide a 259 unit apart-hotel (C1 use), including a 69.5sqmm unit at ground floor level for A1, A3 or A4 use. This 2008 application was called in by Secretary of State on 23rd October 2008 following the Committee's resolution to grant permission, as it was considered by him that the proposed development may conflict with national policies. The application was the subject of a public inquiry, where permission was granted, subject to conditions and a legal agreement on 3rd December 2009.
- 1.29. Officer's note that within the Inspector's conclusions it was stated: (i) 'The proposed development would make efficient use of under-used and unsightly urban land. It would be of a high quality and inclusive design and it would take opportunities to improve the character and quality of the area. It would enhance the setting of Olympia Two and other nearby listed buildings, as well as the character and appearance of the Olympia and Avonmore Conservation Area and the setting of adjoining Conservation Areas. It would promote sustainable travel, without causing unacceptable parking pressures on nearby streets. It would also be a sustainable and suitably located form of development, which would complement the existing use of the Olympia Exhibition Centre, accord with UDP Policy E11 and help to achieve Local Plan objectives in relation to employment and tourism'. It also stated that (ii) 'The design, sustainable travel and regenerative benefits of the scheme, in my view, would outweigh the minor

breach of the BRE Guide and UDP Standard 13.1 in relation to nearby apartments. That a lower form of development on this 'Opportunity Site' would have the same effect as the proposed apart-hotel in terms of daylight and outlook, and be less successful in design terms, adds considerable weight to that conclusion'.

- 1.30. Officers also note in regard to G-Gate that on 18th December 2012 the above 2008 scheme was commenced, and this was confirmed through the issuing of a Certificate of Lawfulness (2012/04239/CLE). Subject to the discharging of the relevant planning conditions and S106 clauses, the development could therefore be delivered. As the development had commenced the applicants paid the council £55,000 towards landscaping, highways works and apprenticeship schemes, as required under the terms of their legal agreement.

Pillar Hall

- 1.31. 2014/03163/FUL – permission granted 10th November 2014 for the change of use of the ground floor of Pillar Hall and the Olympia Room from exhibition centre (Class D1) to restaurant use (Class A3); demolition of existing ground floor link buildings and brick wall between Pillar Hall and Grand Hall and erection of a two storey glazed link building between Grand Hall and Pillar Hall to accommodate new entrance and kitchen facilities together with new front stone steps, lift and railings; Removal of non-original canopy at the front elevation of Pillar Hall entrance; Existing window at ground floor level on the north elevation of Pillar Hall to be reinstated; installation of metal mesh to screen plant; creation of an external eating/drinking area fronting Olympia Way.
- 1.32. 2010/02183/FUL – permission granted 16th December 2010 for the change of use and external alterations to Pillar Hall for provision of a restaurant (Class A3) on ground floor level, with offices (Class B1) on mezzanine, first and second floors, ancillary storage at basement level; alterations to Olympia Way entrance, alterations to north, south and west elevations including creation of window openings; erection of two storey side (south flank) extension, between the Grand Hall and Pillar Hall incorporating a replacement bridge link to Pillar Hall at first floor level; alterations to the existing link bridge at ground floor level and a plant area screened with a metal mesh screen; alterations to north elevation of Grand Hall, relocation of the wall to the north of Pillar Hall, together with revised servicing arrangements.
- 1.33. 2010/02184/LBC – consent granted 17th December 2010 for the refurbishment and alterations to Pillar Hall, including demolition of single storey link extension between Grand Hall and Pillar Hall; erection of a two storey side (south flank) extension to accommodate entrance and kitchen facilities, replacement bridge link to Pillar Hall at first floor level, alterations to the existing link bridge at ground floor level and a plant area screened with a metal mesh screen; insertion of mezzanine office floor at second floor level; creation of staircase linking first floor to the new second floor; second floor balustrade exposed and cleaned; removal of modern partitions; alterations to existing staircore including insertion of lift; replacement of first floor link to Grand Hall; works associated with foundation enlargements at basement level; creation of window openings on north, south and west elevations; removal of entrance canopy to Olympia Way and replacement steps incorporating lift; facade cleaning and repair; creation of a

link to the Grand Hall and associated alterations to window opening on north elevation, demolition and relocation of boundary wall on the north side of Pillar Hall, and associated internal alterations.

- 1.34. 2013/03868/FUL and 2013/3869/LBC – permission and consent granted 19th February 2014 for the demolition of the existing entrance building and security building along with all associated structures and replacement with a new entrance building, hard and soft landscaping, restoration works to the existing to listed building, to entrance building, hard and soft landscaping, restoration works to the existing to listed building, together with plant and equipment.

West Hall

- 1.35. 2010/02165/FUL and 2010/02181/LBC – permission and consent granted 13th October 2010 for Internal alterations to ground floor of Olympia II building to create a marshalling facility and loading/unloading bays including removal of escalators and stairs from ground to first floor; infilling of remaining first floor lightwell, demolition of internal wall between exhibition hall and yard and demolition of internal walls between yard and Hospital Avenue, removal of two storey blockwork office building in yard, creation of new vehicular opening to Portcullis Avenue with roller shutter and erection of partition walls at ground floor level to create operational facilities.
- 1.36. 2010/02180/FUL and 2010/02181/LBC – permission and consent granted 16th December 2010 for the erection of a two storey exhibition hall and conference facility (Class D1) at ground and first floor level of the West Hall behind the retained facade to Blythe Road, comprising a new visitor entrance on Blythe Road; alterations to existing pedestrian footpath and relocation of L-Yard perimeter wall and modifications to existing vehicular servicing arrangements

Central Hall

- 1.37. 2010/02185/LBC – consent granted 13th December 2010 for internal alterations to ground floor of Olympia II building to create a marshalling facility and loading/unloading bays including removal of escalators and stairs from ground to first floor; infilling of remaining first floor lightwell, demolition of internal wall between exhibition hall and yard and demolition of internal walls between yard and Hospital Avenue, removal of two storey blockwork office building in yard, creation of new vehicular opening to Portcullis Avenue with roller shutter and erection of partition walls at ground floor level to create operational facilities.
- 1.38. 2010/00288/LBC - consent granted 16th march 2010 for the Internal alterations including Infilling of the atrium / lightwell at first floor level of Olympia 2 building to create additional exhibition accommodation of 598sq.m, by inserting a steel and concrete floor; Existing cantilevered structured removed and a new glazed screen erected to separate the existing bar from the newly erected exhibition area; New light fittings and suspended ceiling to the new ceiling at ground floor level to match existing; Existing glazed handrails a first floor level removed and re-used to provide protection to the public.

- 1.39. 2010/01215/FUL - permission granted 14th September 2010 for the change of use of Olympia 2 level two from auction room (Sui Generis) to exhibition hall (class D1) and ancillary catering facilities.

Maclise Road MSCP

- 1.40. 2018/00745/FUL and 2018/00746/LBC – permission and consent granted 11th July 2018 for the change of use for a temporary period of 3 years, of part of the rooftop and Level 5B of the car park, to a restaurant use (Class A3) with the capacity for up to 500 people and ancillary services (Level 5B) including erection of a light-weight timber-framed roof extension; installation of ventilation extracts and 7no. air conditioning units at rooftop level; associated internal and external alterations and car and cycle parking facilities.

Within the Surrounding Area

- 1.41. Although not within the application site itself, there a relevant development near to the application site that are considered relevant.

L-Yard

- 1.42. L-Yard is accessed from Blythe Road and is located between the Maclise Road MSCP and West Hall. Although it is historically part of the Olympia site, it is not within the application boundary and sits outside of the applicant's ownership.
- 1.43. 2018/02319/FUL and 2018/02320/LBC – application withdrawn 7th November 2018. Proposal was for the erection of two additional floors; formation of a roof terrace at roof level; basement excavation, erection of a lift enclosure at ground floor level; erection of cycle and refuse storage and landscaping in connection with change of use from a Gymnasium (Class D2) to a Hotel (Class C1) with an ancillary bar/restaurant at ground floor level.
- 1.44. 2006/01537/FUL (with 2006/01597/CAC and 2006/01596/LBC) – permission granted 26th September 2006 for the change of use of a four storey workshop within the Olympia complex to a health and fitness club (Class D2) and offices (Class B1) and associated internal and external alterations including the demolition of an existing storage shed.

66 Hammersmith Road

- 1.45. Officers note the resolution to grant planning permission at committee on 9th October 2018 under application ref. 2017/04752/FUL for the demolition of the existing building and erection of a building of up to 8 storeys in height comprising 17,486 sqm of new Class B1 office floorspace (including 904sqm of affordable workspace/studio space), 850sqm of Class A1/A3/D2 flexible retail/restaurant/gym floorspace, new public realm, plant, car parking, cycle parking and associated works.

RBKC

- 1.46. Officers note the planning permission on the site directly to the south-east of the site and adjacent to the railway line known as 375 High Street Kensington.

Permission was granted on 30th July 2010 under ref. PP/10/01539 for the construction of a one form entry primary school (Use Class D1) of up to 4,800sqm with matters reserved on appearance, landscaping, layout and scale and the demolition of existing buildings an erection of 7 new buildings including buildings of up to 17 storeys in height; flexible Use Classes A1(retail), A2(financial and professional services), A3(cafe/restaurant) and/or A4(drinking establishment) up to 461 sqm; the provision of 467 market residential units and 63 affordable housing units; hard and soft landscaping works; highway and infrastructure works; engineering works including basement and lower basement excavation works; plant & equipment and all necessary associated and ancillary works

2.0 PROPOSAL

- 2.1. During the later half of the 20th Century, prior to statutory listing of the exhibition halls in 2003, works to extend, improve and modernise the various buildings on the Olympia site were carried out in a piecemeal fashion. Some elements of those works now cumulatively detract from the special interest of the listed buildings and the character and appearance of the Conservation Area.
- 2.2. More recently the previous owners of the exhibition centre carried out various projects to rejuvenate the Olympia estate including the redevelopment of West Hall, the installation of a mezzanine within Olympia Central, the conversion of the ground floor of Olympia Central to form a marshalling yard and the refurbishment of the Olympia Central façade. Although those projects have been successful, other approved projects have not been implemented, including the redevelopment of the G-Gate site for hotel use, the conversion of Pillar Hall to office use, the removal of single storey buildings in front of Grand Hall, the restoration of the Grand Hall façade and public realm improvements to Olympia Way.
- 2.3. The constant need to keep up with modern standards and to maintain Olympia's position as a venue of national importance will make further works and alterations necessary, in particular relating to:
 - Reuse of under utilised buildings on the site.
 - Redevelopment of the vacant G-Gate site.
 - Improving the visual interaction with the context to enhance townscape character and wayfinding.
 - Incorporating active frontages in appropriate locations to provide better facilities and to improve integration with the context.
 - Facilitating a wider range of potential events and functions.
 - Improving the quality of the exhibition floorspace and the food and beverage offer.
 - Providing a wider range of uses on the site to support the functioning of the core exhibition business, including hotels and restaurants.
 - Creating permeability through the site to improve the integration into the townscape and optimise the use of new activities within the building.
 - Improving the street spaces around the site and creating new amenity spaces.
 - Reconfiguration vehicle access and servicing.
 - Improving technical services and environmental standards.

2.4. The main principles of the masterplan are:

- To retain the exhibition centre use as a valuable contributor to London's economy and to sustain that use in the longer term, which will allow the most important heritage assets on the site to be retained in their original use, for which they are specifically designed.
- To removal visual clutter and accretions to the existing buildings which has developed around and between the exhibition halls.
- To introduce new uses to the site to complement and sustain the original exhibition centre use in the longer term, including in response to exhibitor feedback.
- To create a world class destination with a variety of uses and a much improved cultural offer.
- To provide new office floorspace to create a hub for creative, media and create industries.
- To develop new routes and public realm within the site to create greater permeability and open up the site to the public over a longer period of the day.
- To create active frontages to transform the image of the existing site at street level.

2.5. The masterplan provides a strong framework to sustain the continuation of the exhibition centre use, to manage the development of the site and the delivery of public benefits. The provision of a basement Logistics Centre will assist with removing servicing from the public realm in order to allow public realm and environmental benefits. The removal of later infill development between the exhibition halls and plant from roof level will improve the appearance of the listed buildings on the site and allow the creation of a public route through the Olympia site. By necessity the route will run at second floor level in order to allow the free movement of visitors between exhibition halls at ground and first floor levels, which is essential for the successful operation of the exhibition centre business. The masterplan also uses opportunities to bring under utilised buildings and vacant areas of the site back into beneficial use, based on an assessment of the significance of the heritage assets on the site.

2.6. The masterplan has evolved through as part of an iterative design process in parallel with the pre-application process including meetings with Historic England and a series of public consultation events. Significant revisions have been made to the design and massing of the National Hall hotel extension, the design of the Level 2 sky deck, the height, massing and design of the Olympia Central redevelopment, the design and extent of the mezzanine levels in Grand Hall and National Hall and to the design of the public realm along Olympia Way. Heritage benefits including the reinstatement of lost features to the facades of Grand Hall and Olympia Central have also been incorporated into the application scheme.

The Current Application

2.7. The current application seeks full planning permission for the comprehensive redevelopment of the site set out above comprising:

- Central Hall - demolition with retention of listed façade to Hammersmith Road, erection of new ground plus 12 storey building for office, exhibition, flexible retail, and flexible office/conference uses; new site-wide logistics centre, car/cycle parking at two new basement levels
- G-gate site - erection of ground plus 9 upper storeys building with two levels of basement for use as a theatre, exhibition and flexible restaurant/bar use at ground/level 2 and roof level
- National Hall - three storey roof-level extension for use as hotel, additional exhibition space and flexible exhibition/restaurant/bar use
- West Hall - alterations and extension to provide two additional storeys for use as live music and performance space
- Maclise Road Multi Storey Car Park - partial demolition, alterations and extension for use as hotel, cinema, and flexible co-working/conference use
- Grand and National Halls - demolition of existing accommodation and circulation spaces between halls and construction of new Level 2 public realm deck with glazed canopy comprising flexible retail uses
- Pillar Hall - alterations for use of building for restaurant/bar with ancillary live music
- Grand Hall – additional internal floorspace for exhibition space and flexible exhibition/restaurant/bar use;
- Public realm and landscaping with new pedestrian, vehicular and pedestrian accesses and internal routes.
- Plant and energy centres

2.8. The proposed heights of the various areas of the proposal are:

	Existing Height AOD	Existing Height From Pavement	Proposed Height AOD	Proposed Height From Pavement
Grand Hall	40.7m	36.7m	40.7m	36.7m
National Hall	29.3m	23.9m	32.3m (hotel)	26.9m
Central Hall	33.9m	28.4m	78.5m	73m
West Hall	22.5m	17.1m	34.8m	29.5m
G-Gate	0m	0m	57.8m	51.9m
Pillar Hall	28.1m	24.4m	28.1m	24.4m
MSCP Car Park	26.5m	22m	31.4m	26.9m
L2 Public Realm	-	-	34.4m (to canopy)	30m

2.9. The existing site has a total floor area of 98,706sqm, all of which is Class D1 exhibition space and plant with the addition of 1,129sqm of Class A3 restaurant space on the ground floor of National Hall. The proposal would increase this to 186,204sqm. The proposed uses per building are set out in the table below:

Building	Proposed Use	Use Class	Proposed GIA Sqm	Proposed GIA sqm - Total
Grand	Exhibition	D1	23,670	25,450
	Exhibition / F&B	D1 / A3 / A4	878	
	Plant	-	902	
National	Exhibition	D1	13,432	22,103
	Hotel	C1	6,373	
	Retail / F&B	A1/A2/A3/A4	75	
	Exhibition / F&B	D1/A3/A4	512	
	Plant	-	1,711	
Central	Exhibition	D1	7,848	81,632
	Office	B1	53,487	
	Retail / F&B	A1/A2/A3/A4	468	
	Conference / Co-Working (Office)	D1/B1	2,235	
	Site Logistic	-	10,207	
	Music Venue	D2	182	
	Theatre (SG)	Sui Generis	273	
	F&B	A3/A4	45	
	Plant	-	6,887	
G-Gate	Theatre	SG	7,663	17,376
	Exhibition	D1	1,902	
	F&B	A3/A4	1,250	
	Exhibition / F&B	D1/A3/A4	2	
	Retail / F&B	A1/A2/A3/A4	41	
	Site Logistics	-	3,993	
	Office	B1	85	
	Music Venue	D2	9	
	Conference / Co-Working (Office)	B1/D1	3	
	Plant	-	2,428	
West	Exhibition	D1	9,170	15,897
	Music Venue	D2	5,927	
	Plant	-	800	
MSCP	Cinema	D2	1,165	19,455
	Hotel	C1	9,832	
	Co-Working (Office) / Conference	B1/D1	7,397	
			1,061	
Pillar Hall	F&B	A3/A4	2,764	2,967
	Plant	-	203	
L2	Retail / F&B	A1/A2/A3/A4	1,272	1,272
L-Yard	Plant	-	52	52
Total				186,204

- 2.10. Listed Building Consent is also sought for the internal and external works proposed above under application ref. 2018/03101/LBC
- 2.11. In support of the planning application and Listed Building Consent the applicant has submitted the following documents:

- Application drawings
- Arboriculture Report
- Basement Impact Assessment
- Olympia London Business Case
- Design and Access Statement
- Draft Construction Management Plan
- Energy Assessment Report
- Environmental Assessment Report
- Environmental Statement Volume 1: Main Environmental Statement
- Environmental Statement Volume 2: Heritage, Townscape and Visual Effect Assessment
- Environmental Statement Volume 3: Technical Appendices
- Environmental Statement Non-Technical Summary
- Flood Risk Assessment and Drainage Strategy
- Phase 1 Geotechnical and Geo-Environmental Desk Study
- Operational Waste Management Strategy
- Refuse and Recycling Management Plan
- Security Design and Access Statement
- Statement of Community Involvement
- Structural Report
- Sustainability Statement
- Town Planning Statement
- Transport Assessment with Car Park Design and Management Plan; Framework Delivery and Servicing Plan; Framework Construction Logistics Plan; Framework Event Management Plan; Framework Travel Plan

2.12. **Environmental Statement**

- 2.13. An Environmental Impact Assessment (EIA) has been undertaken and an Environmental Statement (ES) has been submitted by the applicants under the Town and Country Planning (Environmental Impact Assessment) Regulations 2017 for both this application and the adjoin masterplan application under ref. 2018/03100/FUL and 2018/03101/LBC. This requires certain projects to be assessed to establish whether they would have any significant effect on the environment. The scale of the proposals means that it is EIA development requiring an ES.

- 2.14. The ES comprises:

- Environmental Statement Volume 1: Main Environmental Statement
- Environmental Statement Volume 2: Heritage, Townscape and Visual Effect Assessment
- Environmental Statement Volume 3: Technical Appendices

- Environmental Statement Non-Technical Summary

2.15. In summary the ES concludes that the overall Olympia proposal set out in the full and outline applications when operational development is likely to result in the following impacts:

EIA Topic Area	Masterplan Site	Masterplan + Olympia Way
Socio-Economics	<p>Major Beneficial</p> <p>-National: Exhibition provision</p> <p>-Regional: Operation employment</p> <p>-Borough: Hotel provision</p> <p>-Local: Food and beverage provision</p> <p>Moderate Beneficial</p> <p>-Borough: Office, retail provision</p> <p>-Local: Public realm</p>	The provision of public realm would change to Major Beneficial
Townscape	<p>Major Beneficial (Local)</p> <p>Character Area 1 (Large institutional development from 19th and mid 20th century</p> <p>Moderate Beneficial (Local)</p> <p>Character Area 5 (Large commercial frontages on the north side of Hammersmith Road. Kensington High Street)</p>	No Change
Built Heritage	<p>Major Beneficial (Local)</p> <p>Grand Hall, Pillar Hall, National Hall, Central Hall</p> <p>Moderate/Major Beneficial (Local)</p> <p>Olympia and Avonmore Conservation Area</p> <p>Moderate Beneficial (Local)</p> <p>MSCP</p>	No Change
Views	<p>Major Beneficial (Local)</p> <p>View 1 (West from railway bridge)</p> <p>View 3 (east of junction between Hammersmith</p>	Additional potential benefit effects: Major Beneficial (Local)

	<p>Road and Southcombe Street) Moderate Beneficial(Local) View 4 (North End Road at junction with Fitz-James Avenue) View 5 (Avonmore Road) View 8 (Napier Road at junction with Addison Road)</p>	<p>View 2 (Olympia Way and Hammersmith Road) Moderate Beneficial (Local) View 15 (Entrance Grand Hall)</p>
Wind Microclimate	<p>Negligible to Minor Beneficial (Local) Entrances (on-site)</p>	No Change
Air Quality	<p>Moderate Adverse (Local) R2 (Hammersmith Road)</p>	<p>Additional potential adverse effect: Moderate Adverse (Local) R3, R8 (Hammersmith Road) R4 (Blythe Road)</p>
Noise (Delivery and Servicing Noise – night)	Not significant	<p>Significant Adverse Sinclair Road, Maclise Road</p>
Daylight	<p>Major Adverse (Local) 1-35 Argyll Mansions 67-81 Hammersmith Road Moderate to Major (Local) 1-50 Palace Mansions Moderate Adverse (Local) 1-31 Glyn Mansions 72 Blythe Road Minor to Moderate Adverse (Local) 85-97 Hammersmith Road 89 Hammersmith Road</p>	<p>Additional potential adverse effect: Moderate Adverse (Local) 2 Sinclair Road</p>
Sunlight	<p>Moderate Adverse (Local) 6 Beaconsfield 3 Sinclair Road 2 Sinclair Road 8 Sinclair Road 388 Kensington High Street 1-50 Palace Mansions 1-35 Argyll Mansions 72 Blythe Road</p>	No Change

	Minor/Moderate Adverse (Local) 5 Sinclair Road	
Overshadowing (Sun Hours on Ground)	Moderate Adverse (Local) 2-4 Sinclair Road	No Change
Light Spillage	Moderate Adverse (Local) 1-50 Palace Mansions 1-35 Argyll Gardens 67-81 Hammersmith Road 72 Blyth Road	No Change
Climate Change (Contribution of GHG to the environment)	Significant Adverse (Global) Global climate	No Change

2.16. Overall however, the redevelopment of the Olympia Estate proposes the comprehensive refurbishment and regeneration of Olympia London to ensure that Olympia maintains its status as a world-class exhibition destination through improving and enhancing exhibition and conferencing facilities and delivering a range of supporting and complementary uses including flexible office accommodation, visitor accommodation, food and beverage facilities and destination leisure and cultural uses. The likely significant beneficial effects relate to:

- Provision of new employment opportunities through the introduction of new land uses and additional floorspace
- Land uses and floorspace introduced to the Olympia Estate to help meet borough, regional and national requirements include: new office floorspace, provision of new hotels, new retail floorspace, additional food and beverage floorspace, enhance and provide additional exhibition floorspace
- Provision of new public realm and improving permeability through Olympia
- Improvement and enhancement to the statutory listed buildings within the masterplan
- Improvements and enhancements to the quality of the surrounding townscape, including the Olympia and Avonmore Conservation Area
- Improvements and enhancements to local views
- Wind microclimate effects at on site building entrances

3.0 PUBLICITY AND CONSULTATIONS

Consultation Responses

Greater London Authority (GLA)

3.1 The Mayor of London Stage 1 response is summarised below:

3.2 Land use principle: The proposals to regenerate Olympia Exhibition Centre as a major visitor attraction, and new business, leisure, and cultural quarter,

enhancing London's world city status are strongly supported in principle by London Plan and draft London Plan policies.

- 3.3 Design and heritage: The proposals would introduce significant new build elements of a high quality. The design, height and massing of the proposals are supported. The new buildings would result in less than substantial harm to heritage assets, and such harm is outweighed by the benefits of the proposals, which include the refurbishment and enhancement of historic buildings and the restoration of the venue to its original iconic status. The design should be further developed in terms of promoting a route through L-Yard, revising the design of the new flue, and introducing further articulation to the G-Gate theatre box. Additional information on inclusive design is also required.
- 3.4 Climate change: Additional technical information is required in relation to the applicant's energy strategy. Further passive and energy efficiency measures should be considered. The applicant should outline the measures to future proof the site to allow for a future connection to a district heating network. In addition, further information is required on the heat pump technology and its effect on air quality.
- 3.5 Sustainable urban drainage: In line with the London Plan drainage hierarchy, further details on SuDS measures are to be, and how greenfield runoff rate will be achieved, should be provided before the application can be considered fully compliant in line London Plan Policy 5.13 and Policy SI.13 of the draft London Plan.
- 3.6 Transport: TfL raised initially raise concerns to the proposed development, however following engagement with officers and the applicant the TfL position set out within the Stage 1 is as follows. The development proposals would generate a significant number of additional trips on the public transport network and these need to be mitigated accordingly. Key requirements include additional gate line capacity and customer facility enhancements at Kensington (Olympia) station, £1.8m for bus capacity improvements and £200,000 for cycle hire. Temporary and permanent highway schemes, catering for Cycle Superhighway 9 must be secured. Planning conditions and obligations are required to protect safety and operations on the transport network; and car parking for the exhibition use should be limited to operational needs and disabled persons only.
- 3.7 Historic England: The principle of development is supported, however concerns are raised regarding the scale and expressive design being incongruous in the context of the listed buildings and surrounding conservation area. Whilst HE do not support the proposal as submitted, it is considered that the proposal results in less than substantial harm and the determination of the application is delegated to the local authority to weigh the harm against the public benefits.
- 3.8 London Underground Infrastructure Protection: No objection
- 3.9 Thames Water: No objection, however identify inability of the existing combined water infrastructure and water network infrastructure to accommodate the needs of the development. Conditions and informatives are recommended.

- 3.10 Natural England: No objection. Consider the proposal would not have significant adverse impacts on statutorily protected sites.
- 3.11 Royal Borough of Kensington & Chelsea (RBKC): Object to the proposal for the following reasons: harm to public transport, risk to pedestrian safety, increased parking pressure within the borough, impact on views from RBKC from conservation areas and the setting of listed buildings within RBKC. Further comments received request contributions to wayfinding toward attractions within RBKC; lighting and pavement improvements to Holland Road and High Street Kensington; and employment opportunities for RBKC residents.

Residents and Amenity Groups

- 3.12 The development has been advertised by means of a site notices posted around the site on 23rd October 2018, press advert published 26th October 2018 and approximately 3310 individual notification letters sent to the occupiers of properties around the application site. A total of 360 responses have been received, including representations from local amenity groups. The contents of these representations are summarised below.

Support

- 3.13 172 representations have been received in support of the detailed application, and 21 for the Listed Building Consent application. 11 representations have been received which neither support or object. Many of the support comments express a positive view for redevelopment. Other specific comments are summarised below:
- Benefits to residents and businesses from new office, restaurant, cinema, and cinema space.
 - Links/permeability through the site.
 - Theatre and cultural provision.
 - Proposals keep the Olympia Exhibition Centre operating, and would restore and improve exhibition space.
 - Provision of more local amenities in the area.
 - Inclusive and accessible design incorporated into the scheme.
 - Creation of a business hub, a national and international cultural, a leisure hub and a destination.
 - Increase opportunity for cycling.
 - Integration of Olympia into the local community.
 - Improve surrounding areas.
 - Boost the local economy, including creation of more jobs.
 - Provides an exciting modern design which respects the historic fabric.
 - New landscaping would offer environmental benefits.
 - Opportunity for business to expand and bring life into the area.
 - Reduce congestion in Shepherds Bush.

Objection

- 3.14 106 objections received to date on the detailed application and 47 for the Listed Building Consent application. These have been summarised below:

Traffic/Transport

- Pedestrian flows would increase resulting in dangerous conditions.
- Overload the transport network, more traffic, congestion on local streets.
- Inadequate public transport provision. No capacity for increased use.
- Lack of information and huge impact on Kensington Olympia Station. Not realistic without District Line reinstatement.
- Add to parking pressure in surrounding streets. Reduction to parking provision unacceptable. Resident parking permits are required.
- Real time truck volumes and movements for events into the Logistics Centre are not shown.
- Uber/ taxi drop off and waiting in nearby streets.
- Closure of Olympia Way – no easy access for residents.
- Lorries on Blythe Road and increased right hand turn.
- Unclear on the future of the Motorail carpark.
- No studies provided on increased traffic and footfall to surrounding streets.
- Access points are not spread sufficiently around the site.
- Increase in courier vans and bikes for delivery and collection.
- Safety of Olympia Station with large amounts of people spilling onto Olympia Way and Hammersmith Road – especially if Olympia Way Outline isn't implemented.
- Increased construction traffic and cumulative impacts.
- Construction worker travel to and from site.

Design/ Heritage

- Non-descript buildings proposed. No intrinsic identity.
- Theatre blank concrete façade, oppressive, imposing and brutalist. Would look rundown and dated within a few years. Theatre is ugly.
- Design of Hotel on MSCP inappropriate in relation to the Olympia Building and listed MSCP architecture.
- Office and Hotel above National Hall, Car Park and Theatre are unsympathetic in design and scale.
- Non-consistent architecture
- Over use of curves in the design.
- Proposals treat the site as an island without considering surrounding context.
- Out of context with character/ historical use on the site.
- Detrimental to surrounding conservation areas. Substantial harm to heritage assets without greater public benefit.
- Internal alterations to MSCP and Halls alter the character.
- Block out the dome of the exhibition halls.
- Overdevelopment. Height too tall, massive, and bulky.
- Scale and size of development inappropriate outside a regeneration area or town centre location.
- Cooling chimney is visible, prominent, and out of character.

Environmental Considerations

- Pollution from more traffic, idling traffic, and ubers/ taxis etc.
- More pollutants (CO2 emissions) and noise from construction, increased dust, more noise, and light pollution.
- Proposal within 20m of Counters Creek. Has not been flagged.
- Lack of green space provided and no detail, and removal of greenery.

Other

- Length of consultation period outlined is too short.
- Length of construction period will take very long.
- Lack of information & misrepresentation of plans given during the applicant's consultations (pre- submission).
- Impact on neighbouring residential buildings to south, south west, west, and north, including Argyll Mansions.
- Loss of daylight, overshadowing, loss of privacy.
- Overload on essential public services e.g. water/sewer.
- Would change character of residential area to a mini city). Proposed uses including night uses more appropriate within a Regeneration or Town Centre area.
- No construction programme, timing and phasing given.
- Empty office space exists in Hammersmith. No justification for more office space provided.
- Late night noise, crime, anti-social behaviour etc from other uses (music venue largely), accumulation of rubbish and lack of bins.
- Impact of development on existing uses in Hammersmith etc (shops, cinema, theatre etc). Loss of business to other parts of borough.
- Change of use from predominantly daytime to a more night-time base.
- No need for theatre given proximity of the Lyric and other theatres.
- No local amenities provided (gym, creche, services or community spaces).
- No local employment, or local benefits except for bars/restaurants.
- Impact on Local Police services, security during winter and night hours.
- Existing amenity for the community will be under more pressure (gyms, pools, supermarkets, parks) from workers/ visitors associated with the development.
- Crowd management. How will this be controlled to prevent bottlenecks?
- Should include affordable housing provision.
- Increase costs to residents for upkeep, impacts on local services.
- The site is not designated for this scale of development
- Public realm at second floor more a food court
- Financial viability undermined by expensive facades and structural cantilevers
- Vibration impacts from a music venue
- Viability of a theatre in this location

3.15 The Sinclair Road Resident's Association have commented as follows:

- An overdevelopment, which compromises the architectural merit of the listed buildings.

- The viability of proposals is dependent on public transport improvements such as the increased services on the Overground and reopening of the District Line. Even with additional services it would not be sufficient to meet the projected increase in footfall.
- Lack of studies provided on the safety at Kensington Olympia station, and spill onto Hammersmith Road. Lack of information on local street network and traffic impacts.
- The proposal will result in a change of use, while it is not located within a designated regeneration site. There is no mitigation or protection for residents.
- Light pollution.
- Level 2 is not public realm space more a food court.
- Olympia Way will be narrowed and become an arterial thoroughfare.
- Set back to North End Road/Hammersmith Road not large enough to serve as public amenity.
- Blythe Road/Beaconsfield Terrace is to the rear of Olympia with no functional or architectural engagement with its neighbours.
- Misrepresentation of the proposed heights
- Olympia Central – too high, bulky/sprawling. Encroaches on the listed building; not functionally, stylistically, or volumetrically connected to the listed building below; folded glazing is cut and paste pastiche unlikely to survive value-engineering; financial viability undermined by expensive façade designs and cantilevers.
- G-Gate – too high; defensive, blank, grain-silo typology, façade material is not sympathetic to the urban context; function is not viable for any community theatre use; building is not served by public space at ground level; stairs are unlikely to be used and two lifts are not prominent.
- Olympia West – does not acknowledge or respect the built context of listed (Blythe House) and residential (Kensington West) buildings; massing is confused, blank facades are brutal response to the residential context; the proposal should not be higher than the landmark building of Blythe House.
- Vehicles – proposed controls are not proven, impact of large numbers of private hire vehicles idling and dropping off in the neighbourhood has not been calculated.
- Pedestrians – access points are not sufficiently spread; insufficient public spaces on the perimeter; aim to increase number of users all times of day and night extending the hours of use; no route through Olympia for pedestrians improved permeability; and the site is not well enough served by public transport.
- Scheme too large to be considered by a full application and should be appraised first as an Outline application.
- Proposals treats the site as an island and do not adequately consider the impact of the urban context.
- Locals misled by artfully presented material during consultation stages.
- Large office development is misplaced in the local context.
- Proposed development is not in accordance with section E1a and E1b and is not within an opportunity area of town centre.

3.16 The Avonmore and Brook Green Resident's Association have commented that Broadly support the proposal given the reduction in HGV traffic, provision of new

bars/restaurants, arts, retail, and jobs. They expressed concern over the height of the office, impacts of vehicles and parking and the impact to residents from the closure of Olympia Way.

3.17 The Hammersmith and Fulham Historic Buildings Group have commented as follows:

- Object due to the significant impact of the proposals on the setting of listed buildings.
- The timeframe for comment was too limited to consider the proposals in detail.
- The tall office building is overly dominant and not sympathetic to the surrounding heritage assets.
- Olympia Central – Offices are over-dominant, unsympathetic, and not subservient to the listed façade of the building.
- G-Gate – Concern over viability of a theatre, the bulk, height, and massing of the proposed G-gate building is excessive and the exposed bare concrete is not appropriate next to a busy road and appears brutal.
- National Hall – Out of scale and proportion and sits uncomfortably above the Edwardian façade. Concern over the internal decks and sense of openness. May limit future use of the hall.
- West Hall – Comfortable with the proposed elevational treatment.
- MSCP – The proposed fluted elevational treatment is inappropriate. Over-articulated and too strident in comparison with the simple clarity of the existing façade.
- Grand/National Halls – Open air escalators will require regulation attention to ensure they do not accumulate litter and function in all weather; and welcome removal of the external clutter.
- Internal Decks – Concerned about the impact on the windows and sense of openness and whether this will limit future uses of the hall.
- Negative impacts on public transport.
- The significant alterations to the buildings require the preparation and implementation of a written scheme of investigation for building recording including a comprehensive photographic survey recorded in the Borough Archives.
- Public benefit does not outweigh the harm.

3.18 The Hammersmith Society have commented as follows:

- Overall development approach is welcome, including mix of uses.
- Proposed buildings appear as isolated, unrelated design interventions without an overall narrative which risk creating an over-busy architectural landscape which distracts from the heritage elements.
- The setting of heritage buildings will be transformed and subservient.
- Heritage elements become incidents and do not focus especially in long views.
- G-Gate –Absence of design creativity. Large areas of concrete offer a cheerless surface which is poorly suited to damp weather. Introduction of a concrete faced building alongside the listed Central Hall façade could devalue the style and concept of this heritage element.

- L2 – Pedestrian access unclear. The stair shaft tucked between theatre and Central Hall could feel oppressive and unwelcoming.
- Central Office Building – Building out of place. Floor plate too long to fit on the implied podium of Central Hall below. The building dominates the skyline, upstaging the setting of Grand Hall.
- National Hotel – Hotel roof extensions introduce an inappropriately prominent and self-conscious design element, far from the recessive integrated characteristics of the mansard style. The repetitive shadowing of the saw-tooth profile sits uneasily with the linearity of the existing brick and stone below.
- Olympia Way – Resolution of the change in level between Olympia Way and the exhibition hall entrance is uncomfortable.
- MSCP – The curved brick bays might enrich this corner, provided the height does not dominate views from the south.
- West Hall – The regular geometric roof plan indicates an orderly set-out which could be lost in street views due to the continuous wrap of cladding and secondary diagonal grid.
- Interior Halls – Support the views and observations of the H&F HBG.

Ward Councillors

3.19 The site is located within the northern part of the Avonmore and Brook Green Avonmore Ward. Addison Ward adjoins Maclise Road to the north. Both sets of Ward Councillors have made representations on the proposal.

3.20 Councillors Harvey, Morton, and Smith (Avonmore and Brook Green Ward)

- Support the application as it would bring benefits to the local area; a reduction in HGV traffic; benefits to the community from bars, restaurants, performing arts, retail, and jobs; boost for local businesses from the increased visitors and office workers.
- There are however still concerns including; the office block is too large and dominant, insufficient parking space for visitors, and risk that closing Olympia way will seriously inconvenience residents.

3.21 Councillors Connell and Fennimore (Addison Ward)

Transport

- Primary concern is the projected increase in footfall of the development.
- Considerable concern about the current level of transport infrastructure and its ability to cope with increased visitor demand.
- We do not believe that the [transport] can adequately absorb additional passenger demand on the scale that would be required.
- We note with concern that residential streets surrounding Olympia have not been studied in the transport and traffic assessment based on increased visitor trips by car.
- Concerns about the development on parking stress in the local area, recognising that Controlled Parking Zones have only recently been strengthened

- Request from TfL that they will restore a full service to the District Line if the development were to proceed.
- We concur with the comments of our colleagues Cllrs. Harvey, Morton, and Smith in relation to the closure of Olympia Way and Blythe Road. We believe further work needs to be completed to understand the potential impact on traffic and congestion of vehicles.

Design

- We believe that the height of the building and its overall scale is overambitious, potentially constituting overdevelopment, and would prefer to see an office extension of a reduced height and scale.
- We are also concerned that the scale and height of the office extension could have an adverse impact on the character of local Conservation Areas, thereby failing to preserve or enhance them.
- The erection of buildings up to 4 storeys on Olympia Way are not in keeping with the Olympia and Avonmore Conservation Area.

Culture

- Ensure that providers such as the Bush Theatre and Lyric Hammersmith are not threatened.

3.22 Tony Devenish (GLA Assembly Member for West Central): Not satisfied the application has been thought through, appears to be overdevelopment with little regard to valid concerns. Concern over the daily footfall and need for a comprehensive Transport Strategy.

Public Engagement

3.23 The applicant provided a Statement of Community Involvement prepared by Connect, that summaries the public consultation that was undertaken independently. Olympus Property Holding Limited held four rounds of public consultation within Pillar Hall (on-site). Exhibitions were advertised through letters, emails, and leaflets. Invitations were extended to neighbouring residents, local businesses, and community representatives (such as local amenity groups/societies and Councillors). The Olympia London website also provided information regarding the exhibitions. Various media outlets also covered the proposals throughout July 2018.

- The first consultation was held on Tuesday 19 September, Wednesday 20 September, Thursday 21 September and Tuesday 26 September 2017. 46 feedback forms were received and the key issues identified were traffic, permeability of the site, type of uses and the district line reinstatement.
- The second was held Tuesday 21 to 23 November 2017 from 4pm to 8pm. 48 feedback forms were received and issues regarding the internal decks, traffic, potential facilities, importance of consultation were raised.
- The third held from Tuesday 3 July to Thursday 5 July from 4pm to 8pm and Saturday 7 July 2018 between 11am and 3pm. 41 feedback forms

were received, issues arose around traffic, the massing and height of proposals, the design, and types of retail offers to be provided.

- The fourth exhibition was held on Tuesday 14 August, Thursday 16 August from 4pm to 8pm, and Saturday 18 August 2018 from 11am to 3pm. 59 feedback forms were received, responses focused on design, construction impacts, traffic, and community offers such as affordable and community space provision.

3.24 Following the first public consultation the applicant held a designated business session for local businesses on the 26 September 2017, and the Avonmore and Brook Green Residents Association on the 10 October 2017. The applicant also held meetings in 2028 with Dance West, LAMDA, Tri-Borough Music Hub, Turtle Key Arts, and the New English Ballet Theatre.

4.0 PLANNING POLICY FRAMEWORK

4.1 As The Town and Country Planning Act 1990, the Planning and Compulsory Purchase Act 2004 and the Localism Act 2011 are the principal statutory considerations for town planning in England.

4.2 Collectively the three Acts create a plan led system which requires local planning authorities to determine planning applications in accordance with an adopted statutory development plan unless there are material considerations which indicate otherwise (section 38(6) of the 2004 Act as amended by the Localism Act).

4.3 In this instance the statutory development plan comprises the London Plan (2016), the Local Plan 2018 and the Planning Guidance Supplementary Planning Document 2018 (hereafter referred to as Planning Guidance SPD). A number of strategic and local supplementary planning guidance and other documents are also material to the determination of the application.

4.4 The National Planning Policy Framework (NPPF) came into effect on 27 March 2012 and was revised in 2018 and is a material consideration in planning decisions. The NPPF, as supported by the Planning Practice Guidance (PPG), sets out national planning policies and how these are expected to be applied.

4.5 The NPPF does not change the statutory status of the development plan as the starting point for decision making. Proposed development that accords with an up to date Local Plan should be approved and proposed development that conflicts should be refused unless other material considerations indicate otherwise.

4.6 The NPPF is aimed at safeguarding the environment while meeting the need for sustainable growth. It advises that the planning system should:

a) plan for prosperity by using the planning system to build a strong, responsive and competitive economy, by ensuring that sufficient land of the right type, and in the right places, is available to allow growth and innovation; and by identifying and coordinating development requirements, including the provision of infrastructure;

b) plan for people (a social role) - use the planning system to promote strong, vibrant and healthy communities, by providing an increased supply of housing to meet the needs of present and future generations; and by creating a good quality built environment, with accessible local services that reflect the community's needs and supports its health and well-being; and

c) plan for places (an environmental role) - use the planning system to protect and enhance our natural, built and historic environment, to use natural resources prudently and to mitigate and adapt to climate change, including moving to a low-carbon economy. The NPPF also underlines the need for councils to work closely with communities and businesses and actively seek opportunities for sustainable growth to rebuild the economy; helping to deliver the homes, jobs, and infrastructure needed for a growing population whilst protecting the environment.

4.7 The NPPF sets out a presumption in favour of sustainable development. For decision-taking this means:

- approving development proposals that accord with the development plan without delay; and
- where the development plan is absent, silent or relevant policies are out of date, granting permission unless:
- any adverse impacts of doing so would significantly and demonstrably outweigh the benefits, when assessed against the policies in this Framework taken as a whole; or
- specific policies in this Framework indicate development should be restricted.

Draft London Plan

4.8 The new draft London Plan was published on 29 November 2017. The Plan's consultation ended on 2 March 2018. The Examination in Public (EiP) opened on 15th January 2019 and publication of the new Plan is expected in the autumn of 2019. It is therefore considered that the new draft London Plan should be given limited weight at this stage in determining this application. In the interim, consideration shall be given to the London Plan (Consolidated with Further Alterations 2016).

4.9 With regards to this application, all planning policies in the National Planning Policy Framework (NPPF), London Plan, Local Plan 2018 and Planning Guidance Supplementary Planning Guidance (SPD) which have been referenced where relevant in this report have been considered with regards to equalities impacts through the statutory adoption processes, and in accordance with the Equality Act 2010 and Council's PSED. Therefore, the adopted planning framework which encompasses all planning policies which are relevant in officers' assessment of the application are considered to acknowledge protected equality groups, in accordance with the Equality Act 2010 and the Council's PSED.

5.0 PLANNING ASSESSMENT

The main considerations material to the assessment of this application have been summarised as follows:

- 5.1 Principle of Development and Land Use
- 5.2 Socio Economics and Community Effects
- 5.3 Design and Heritage
- 5.4 Daylight and Sunlight
- 5.5 Highways
- 5.6 Sustainability and Energy
- 5.7 Flood Risk and Drainage
- 5.8 Ground Contamination
- 5.9 Air Quality
- 5.10 Noise and Vibration
- 5.11 Lighting
- 5.12 Wind and Microclimate
- 5.13 Ecology
- 5.14 Security
- 5.15 Accessibility

5.1 Principal of Development and Land Use

- 5.1.1. **The NPPF 2018** states that applications should be considered in the context of a presumption in favour of sustainable development which meets social, economic and environmental needs and that development proposals which accord with the development plan should be approved without delay. **Paragraph 118** sets out that planning should encourage effective use of land by reusing land which has been previously developed and promotes and supports the development of underutilised land and buildings. The NPPF also promotes mixed-use development, and encourages patterns of growth which focus significant development in locations which are, or can be made, sustainable.
- 5.1.2. **Paragraph 80** of the NPPF states that the planning system should place significant weight on the need to support economic growth and productivity with **Paragraph 81** requiring planning policies to set out a clear economic vision and strategy which positively and proactively encourages sustainable economic growth.
- 5.1.3. **London Plan Policy 2.1** states that the Mayor and the GLA group will ensure that London retains and extends its global role as a sustainable centre for business, innovation, creativity, health, education and research, culture and art and as a place to live, visit and enjoy. **London Plan Policy 4.1** supports the provision of a “strong, sustainable and increasingly diverse economy” across all parts of London. The importance of ensuring “the availability of sufficient and suitable workspaces in terms of type, size and cost, supporting infrastructure and suitable environments for larger employers and small and medium sized enterprises” is noted. The policy explicitly supports the continuing regeneration of Inner London, recognising that the quality of office stock in many locations is aging and deteriorating and therefore not providing an attractive offer for potential occupiers. **London Plan Policy 4.2** states that, as well as supporting the central London office market, office markets elsewhere in the city should be strengthened by focussing new development on viable locations with good accessibility, and enhancing business environments through mixed use

developments which include a range of uses. **Draft London Plan Policy E1** states that new office development should be focused in town centres and other existing office clusters supported by improvements to public transport, walking and cycling. **Draft London Plan Policy E2 (C)** states that the applicant should show how a proportion of low cost and flexible business space would be incorporated into the proposals to provide workspace suitable for small and medium sized enterprises.

- 5.1.4. **London Plan Policy 4.5** and **draft London Plan Policy E10** state that it will be necessary to support the development of visitor accommodation close to major visitor attractions which are outside central London and the designated town centres and opportunity areas, where there is also a clear link in terms of scale, nature and location between the accommodation and the attraction(s) being served. **London Plan Policy 4.6** acknowledges the cultural, social and economic benefits these uses provide, to residents as well visitors. The policy recognises the important role of culture in place-shaping and encourages the expansion of the cultural offer beyond central London, and the benefits that providing a diverse range of leisure and cultural facilities, other than eating and drinking, can generate. **Draft London Plan Policy HC5** seeks to support and protect London's cultural venues, and support the development of new cultural venues, in town centres and areas of good public transport accessibility.
- 5.1.5. **Local Plan Policy E1** supports proposals for mixed use schemes for new employment uses, especially those that recognise the borough's existing strengths in creative industries, health services, bio-medical research and other research based industries. The council will support the retention and intensification of existing employment uses and will require flexible and affordable space suitable for small and medium enterprises in large new business developments. When considering new or extensions to new employment floorspace the following will be taken into account:
- a) whether the scale and nature of the development is appropriate, having regard in particular to local impact, the nature of the surrounding area and public transport accessibility;
 - b) impact upon small and medium sized businesses that support the local community;
 - c) scale and nature of employment opportunities generated in the new development;
 - d) whether there will be displacement of other uses such as community facilities or housing; and
 - e) the Hammersmith and Fulham Economic Growth Plan and the council economic strategies.
- 5.1.6. The preferred locations for new office development above 2,500sqm is within the three town centres and the White City and Earl's Court and West Kensington Opportunity Areas. outside of these areas large office development will generally be discouraged unless it can be demonstrated that provision cannot be provided within those areas.
- 5.1.7. With the justification text for **Policy E1**, Olympia is cited as an example of the borough being an attractive location for multi-national companies and states that the continued presence of large businesses is welcome because of their

contribution to the local economy and in providing jobs and opportunities to residents. The local economy is also buoyed by the very many local office and industrial businesses throughout the borough. The council's Employment Study identified a number of sub-markets within the borough and also identified a need for between 383,000 and 511,000sqm additional office space by 2036.

- 5.1.8. **Local Plan Policy E3** states that permission will be granted for new visitor accommodation and facilities. Outside of the town centres and White City and Earl's Court and West Kensington Opportunity Areas it is considered that small scale hotels and visitor accommodation related to major visitor attractions of sub-regional or greater significance in accordance with the provisions of the London Plan.
- 5.1.9. **Local Plan Policies CF1, CF2 and CF3** set out the council's intention to improve the range of leisure, recreation, sports, arts, cultural and entertainment facilities in the borough including by protecting existing premises that remain satisfactory for their purposes and by seeking new or enhanced facilities where appropriate and viable. New and expanded venues should be accessible and inclusive and seek to address impacts such as noise, traffic and parking. Community uses themselves are defined broadly and can include education and training; health; emergency services; community halls, pubs and libraries; arts, cultural and entertainment uses including tourism, cinemas, theatres, museums, galleries, concert halls, music venues and pubs; leisure, recreation and sport.
- 5.1.10. **Local Plan Policy CF1** is clear that the council will work with its strategic partners to provide high quality and inclusive facilities and services for the community by improving the range of leisure, recreation, sports, arts, cultural and entertainment facilities by a) protecting existing premises that remain satisfactory for these purposes; b) supporting re-provision of facilities for existing users in outworn premises where opportunities arise; and c) seeking new or enhanced facilities where appropriate and viable including as part of major development proposals.
- 5.1.11. **Local Plan Policy CF3** supports the enhancement and retention of arts, cultural, entertainment and leisure uses. It requires proposals for new or expanded facilities to be acceptable in terms of noise, traffic, parking, and opening hours. Supporting text to the policy confirms that some facilities are open during the evening and night-time, helping to sustain a night-time economy through the inclusion of music venues, restaurants, pubs and bars.
- 5.1.12. **Local Plan Policy TLC1** requires that new proposals for town centre uses (including shops, cafes, bars and restaurants) are appropriately located, are of an acceptable scale and do not negatively impact on the existing hierarchy of centres.

Assessment

- 5.1.13. The proposal seeks to retain and develop the existing venue which is the only major exhibition space in central London following the closure of Earl's Court, which would enhance its capabilities and competitiveness as a major international exhibition and cultural venue by way of creating a range of high quality uses. The result of the overall approach taken by the proposal is to

refurbish the existing halls whilst increasing their flexibility and as such their attractiveness to exhibitors. A range of cultural venues would be introduced to the site including a theatre, music venue and rehearsal space as well as hotels, restaurants, a cinema, offices and retail uses. As contended by the applicant, Olympia faces national and international competition with examples such as the Birmingham NEC, London Excel and Paris Expo given, which feature a range of complementary facilities following investment that creates venues that compete for exhibition, travel and tourism. At present, Olympia features the existing halls with the Pizza Express onto Olympia way providing the only on-site supporting use.

- 5.1.14. The proposed scheme consists of a range of non-residential uses that create an enhanced mixed use development supporting and enhancing Olympia for its core operating function as an exhibition centre and its contribution to the borough as well as regionally and nationally. The proposed uses by floor space and by location within the site is summarised as follows:

Use	Use Class	Existing GIA Sqm	Proposed GIA Sqm	Uplift GIA Sqm
Retail/F&B	A1/A2/A3/A4		1,856	1,856
Restaurant	A3	1,129		-1,129
F&B	A3/A4		4,059	4,059
Office	B1		53,572	53,572
Co-Working Office/Conference	B1/D1		9,634	9,634
Hotel	C1		16,205	16,205
Exhibition	D1	75,178	56,022	-19,156
Exhibition/F&B	D1/A3/A4		1,392	1,392
Cinema	D2		1,165	1,165
Music Venue	D2		6,118	6,118
Theatre	Sui Generis		7,936	7,936
Car Parking	-	13,875		-13,875
Site Logistics	-	4,423	14,200	9,777
Plant	-	4,101	14,044	9,943
Total		98,706	186,204	87,498

- 5.1.15. The proposals have the potential to create vibrant new business, leisure and cultural venue and world class visitor attraction and as such the principle of the development is strongly supported at a strategic level in light of the above London Plan policies. The Deloitte exhibition assessment submitted as part of the applicant's Business Case, sets out that Olympia requires improvements to compete at a global level, with key rivals offering a more diversified range of product due to a lack of complimentary facilities on site and in close proximity to the site. Furthermore, it is found that Olympia is not currently capable of competing with internationally renowned venues, including the NEC, due to its limited and non-cohesive exhibition space and lack of complimentary facilities; all other venues have plans to further improve and diversify. It is found that Olympia must modernise its exhibition space, utilise its excellent international accessibility by updating, expanding and diversifying. The near absence of complimentary uses is cited as a fundamental restriction of the site in competing with rivals.

Exhibition and Conference uses

- 5.1.16. The proposal sees the deliver of 63,075sqm exhibition space, 56,022sqm of which is dedicated provision and the remainder being flexible, all within the existing halls. The conference provision comes in the form of 9,634sqm of flexible space alongside co-working space within the extended Multi-storey Car Park. These uses are considered to be well established and comprise the historical core offer of the site, with the proposal refurbishing and enhancing this to modern standards. Subject to assessment of impacts, the principle and land use of this element is supported.

Theatre, Cinema and Music Venue

- 5.1.17. A 1500 seater theatre is proposed on the G-Gate site and as noted in the planning history section, the principle of development on this currently vacant site of a building of a similar mass, height and scale is established by way of the implemented 2008 permission granted by the Secretary of State and the subsequent 2013 permission of a mixed use hotel led development of a similar scale. A 1500 seater music venue is to be provided above the West Hall site, a four screen cinema in the basement below the car park site, with music space also within Pillar Hall.
- 5.1.18. The transport accessibility of the site is excellent in addition to any further enhancement and mitigation required elsewhere in this report. The proposed uses would create a new cultural hub in London and the borough, utilising the existing site's scale and reputation and its transport links. Strategic and local policy clearly supports the development of new cultural venues, in areas of good public transport accessibility and it is considered that the proposal would contribute positively to the cultural offer within the borough and is supported.

Hotels

- 5.1.19. London Plan policy supports the provision of visitor accommodation and states that such development is required to support major visitor attractions outside of central London, opportunity areas and town centres. The approach is further supported by local policy in relation to major visitor attractions of sub-regional or greater significance.
- 5.1.20. The G-Gate site has an implemented permission, by the Secretary of State, for a 259 unit apart-hotel and as such the principle of such a use and scale of provision has been established in this location and at Olympia itself. The proposal comprises a 211 room hotel to the Multi-storey Car Park and a 123 room hotel above National Hall. Olympia itself is a major visitor attraction of national and international standing. The provision would be in extension to the existing site, which therefore does not result in any loss of housing and would utilise the existing public transport links with blue badge car parking provision within the new logistics centre.
- 5.1.21. The principle of hotel uses on the site is established and it is considered that the proposal in this location and in relation to the established major visitor attraction is fully supported by strategic and local planning policy.

Retail Uses

5.1.22. With regard to the provision of Class A retail uses, the applicants contends that the circumstance so of Olympia and the proposal

- The nature and scale of the proposed Class A uses are distinct from the retail offer of local town centres – accordingly they pose no cause for concern in terms of the vitality and viability of the town centre.
- The proposed retail floorspace will meet visitor demand and will additionally support the proposed new businesses and the associated workforce at Olympia. Accordingly, that expenditure is new expenditure and consequently will not be diverted from nearby town centres.
- The submitted Retail Impact Assessment tests maximum floorspace parameters for Class A uses – in reality the amount of Class A floorspace may be much less meaning that the effects are overstated.
- Impacts will be widely dispersed and negligible and will not be derived from nearby town centres.
- There is a specific need for new Class A floorspace as part of the proposals for the regeneration of Olympia. There is policy support to enhance the Borough's visitor, cultural and entertainment facilities.
- Existing town centres perform a vital role and function within the retail hierarchy. Each of those centres will grow according to increases in available expenditure and therefore any impact arising from the application proposals will be phased and short lived.
- The proposed Class A uses are an important ancillary component of the overall proposals for Olympia that will secure important local economic benefits maximising the use of the site.
- No other sites can meet the need to accommodate a range of supporting retail uses which are required in this location to ensure the attractiveness of Olympia to visitors and maintain its status as a world-class exhibition destination.

5.1.23. The proposal features a total of 4,059sqm of dedicated Class A3/A4 (café/restaurant/drinking establishment) uses, with a further 3,248 flexible Class A1/A2/A3/A4 uses (retail/professional services/café/drinking establishment) giving a total of 7,307sqm. The majority of this is made up of 1,272sqm as a flexible offer within the new L2 upper level area, 2,764sqm is a Class A3/A4 use within the reopened Pillar Hall and 1,250sqm is within the new G-Gate theatre site. Of the resulting 186,000sqm the proposal would create, some 2% would be for Class A3/A4 uses compared to the existing 1.1%, and the total Class A offer representing 3.9% with the applicant offering a cap of 600sqm on the amount of Class A1 retail that could be provided under the flexible component.

5.1.24. It is recognised that the purpose for the Class A use provision is to support and enhance Olympia as a venue by way of offering a broad range of complementary uses that currently do not exist on the site, instead relying upon neighbouring offers in the wider area. In this respect the new retail offer would rely upon the proposed uplift. As such the scale of provision is in relation to the overall development being proposed, as opposed to a singular offer simply in relation to the existing exhibition halls and resulting in an overall uplift in Class A provision in the area relying upon the static floorspace and utilisation of the

existing function. As such the scale of the provision is seen by officers as being commensurate within the overall type and quantum of uses proposed.

- 5.1.25. The applicant's Retail Impact Assessment notes the low level of vacancy in the area and remarks that surveys of local town centres demonstrate a low level of vacant units and confirm that each of the centres performs a role and function consistent with their position within the town centre hierarchy with many being small and orientated towards meeting the day to day needs of the local residential and working population and are remote from Olympia. The existing centre do not cater for the needs of visitors to Olympia and are both qualitatively and quantitatively different to the application proposals.
- 5.1.26. The sequential test undertaken considers whether the proposed uses could be provided elsewhere; whether that site is suitable for the proposal; does not take into account whether there are deficiencies in existing provision of if the proposal would be accommodated if reduced and the site must be available now; the business needs of the development are a material consideration. The assessment concludes that there are no suitable or available sequential sites within or to the edge of town centres and as such providing the proposed retail floorspace elsewhere would not meet the identified need of the proposal which is locationally specific to Olympia. Furthermore, the level of trade diversion and impact upon pre-existing uses would be negligible with the proposed expenditure being driven by additional visitors and as such not being diverted from that existing and will not have a significant adverse effect on local town centres.
- 5.1.27. It is therefore considered that the quantum of Class A provision within the development is driven by additional visitor demand and is specific to the location and operation of the site and is acceptable in principle.

Offices

- 5.1.28. The proposal within the Olympia site is made up of two Class B1 office elements: 53,572sqm of Class B1 space above Central Hall; and 9,634sqm of Class B1/D1 space which comprises the co-working offices and conference area to the Multi-storey Car Park. As such, in total the proposal could consist of between a minimum of 53,572sqm and up to 63,206sqm of office use, albeit by removing the conference element that forms part of the applicant's business plan. This represents between 29% and 34% of the total 186,000sqm of the proposed floorspace.
- 5.1.29. The site is not in a designated town centre and is between the town centres at Hammersmith and Kensington High Street with the northern edge of Hammersmith Road featuring medium to large scale office development along its length stretching east from Hammersmith and forms a cluster of office space. At committee in October Members resolved to granted permission at 66 Hammersmith Road which is adjacent to the site on Lyons Walk; this comprised in excess of 17,000sqm of Class B1 office use. The site has very good public transport links, further assessed within the relevant section below.
- 5.1.30. The council's spatial vision within the Local Plan sets out that by 2035 Hammersmith and Fulham will be a key part of, and contributor to, London's

thriving international economy and the benefits of this will be shared throughout the borough. It will be home to centres of innovation, a skilled workforce and a growing number of businesses and jobs providing opportunities for local people. Furthermore, opportunities will have been taken to regain the borough's pre-eminent position for Culture, Media, Arts companies in the borough following the relocation of parts of the BBC from Shepherd's Bush and will have encouraged inward investment, to support new enterprises and start-up businesses and to facilitate job growth in the local area, where all people are connected to economic opportunities and live in strong and thriving communities.

- 5.1.31. Local Plan Policy E1 states that the council will require flexible and affordable space suitable for small and medium enterprises in large new business developments. The proposal would provide this provision through office space, workspace and free use of community spaces as well as community engagement. It is therefore considered that this element of the policy has been satisfied and would accordingly result in a significant public benefit arising from the scheme.
- 5.1.32. Policy E1 goes on to say that when considering new employment floorspace or the extension of existing floorspace the council will also take into account:
 - a. whether the scale and nature of the development is appropriate, having regard in particular to local impact, the nature of the surrounding area, and public transport accessibility;
 - b. impact upon small and medium sized businesses that support the local community;
 - c. scale and nature of employment opportunities generated in the new development;
 - d. whether there will be displacement of other uses such as community facilities or housing; and
 - e. the Hammersmith and Fulham Economic Growth Plan and the council economic strategies.
- 5.1.33. The Council's Employment Land Study (2016), which forms part of the evidence base for the Local Plan, identifies a number of sub-markets for offices across the borough which includes the submarket of Kensington Village, West Kensington and Kensington Olympia. This submarket is recognised as an improving office market in Hammersmith and Fulham because of the improved transport on the West London Line since 2012 following the increased number of trains connecting Kensington Olympia station to Shepherds Bush and Willesden Green to the north and West Brompton, Imperial Wharf and Clapham Junction to the south. In terms of future office supply in the borough, the study identifies Kensington Olympia as an area of possible future supply for B1 office stock and states that this could be developed to include more B class use. In addition to this, the Olympia Centre Car park is also recognised as a site where potential B class uses could be developed in the future. The London Office Review 2014 projected a likely requirement for an additional 290,000m² (gross) of office floorspace within the borough to 2036. However, the Council's Employment Study (2016) predicts a higher need of between 383,000 and 511,000m² based on 1 person per 9m². The proposed office development at Olympia would help to meet this need and therefore contribute a large proportion of the borough's identified modern, high class quality office space requirements.

- 5.1.34. The applicant has submitted a Business Case for the proposal which contains an assessment by an appointed consultant, Cushman and Wakefield, of the provision and location in the context of other town centres. This concludes that the proposed office space would not be competing with other town centres but would provide a complementary offer and that Hammersmith town centre does not have a suitable environment for this scale of accommodation. It is set out that Hammersmith has a diminishing developable space with projects coming forward on Hammersmith Road and adjacent streets and projects outside of the core area are increasingly uncommon and the pace of redevelopment of outdated stock is lagging behind the average. It is concluded that the provision of modern co-working, creative spaces surrounded by arts, performance and food uses is a very attractive offer with most occupiers looking for space that is beyond simply a place to work. The Deloitte report states that high quality office space is limited in the surrounding area and the proposed provision will generate revenue outside of event times as well being an important segment for corporate events; it is stated that the offices are intended to be occupied by key media, tech and professional services tenants to encourage cross-utilisation of the venue space
- 5.1.35. Policy E1 is clear that locations outside of town centres and regeneration areas have a key role to play in delivering the scale of office accommodation required to meet the council's stated need in order to fulfil the spatial vision set out. Whilst schemes above 2,500sqm outside of these areas will generally be discouraged, they will not be resisted and must demonstrate they could not be provided within those areas. It is considered that evidence has been provided that the quantum of office space provided would be difficult to deliver in any other location, in particular the key centre of Hammersmith, due to not just its scale but also the uniqueness of the overall mix of uses and the resulting offer.
- 5.1.36. Given the nature of the proposed exhibition complex and its ancillary retail uses this could support the level of office development proposed, subject to appropriate provision of transport capacity and mitigation of impacts. The proposed office use is not considered to result in a harmful impact upon neighbouring centres, the local area and could not be provided within those centres or other regeneration areas. Provision would be made through local jobs, procurement and workspace, as well as the community benefits set out within this report, that would offer significant benefits to the local area and local community and is therefore considered in compliance with local, regional and national policy.

Principle and Land Use Conclusion

- 5.1.37. It is therefore considered that the proposed floorspace and the proposed flexible mix of uses, together with conditions limiting the quantum of Class A1 retail and planning obligations securing affordable workspace and community uses, would be complementary to the wider Olympia site and would not undermine the local or nearby centres and would be in accordance with the NPPF, London Plan Policies 2.1, 4.1, 4.2, 4.5 and 4.6, Draft London Plan Policies E1, E10 and HC5, and Local Plan Policies E1, E3, CF1, CF2, CF3 and TLC1.

5.2 Socio-Economic and Community Effects

- 5.2.1. **London Plan Policy 3.1** presents the Mayor's commitment to ensuring equal life chances for all Londoners, borne out of the recognition that meeting the needs of particular groups and communities is key to addressing inequalities and fostering diverse communities. **Policy 4.12** seeks to improve access to employment and employment opportunities for Londoners, supporting local employment, development and training. **Draft London Plan Policy E2 (C)**, states that the applicant should show how a proportion of low cost and flexible business space would be incorporated into the proposals to provide workspace suitable for small and medium sized enterprises.
- 5.2.2. **Local Plan Policy E1** requires flexible and affordable space suitable for small to medium enterprises in new large business development. **Local Plan Policy E4** requires the provision of appropriate employment and training initiatives for local people of all abilities in the construction of major developments including visitor accommodation and facilities.
- 5.2.3. The proposal will generate, as set out within the Environmental Statement, approximately 565 construction related full time equivalent (FTE) jobs per years over the build period. The operational development will generate some 4,560-5,045 further FTE jobs. As a result of the modern and upgraded floorspace, wider benefits would be delivered by way of increasing local expenditure through increased employment levels, additional visitors through the visit, cultural and leisure uses proposed, and job and job opportunities for local residents and companies.
- 5.2.4. The applicant has agreed to provide significant employment, training, apprentice and procurement opportunities. These include affordable space comprising 5% of the total eligible Class B1 floorspace across both this application and the associated outline application together with a payment of £10.5m to provide off-site affordable space. In securing this through the s106 agreement, delivery will be secured by way of requiring this level of provision to be delivered within the main development should the outline application, for whatever reason, not come forward. The space within this application 1,107sqm community space within the Central Class B1/D1 area that will be used by the community for free out of hours and when not in use. Should the 2,767sqm within the permitted outline scheme not come forward, it would be within the main site.
- 5.2.5. Further to this 10% of the construction costs will be offered as local procurement contracts and are secured for the local economy together with 175 apprentices, 2,400 work placements and 222 full-time operational phase workers estimated to value £10m.
- 5.2.6. The applicant has agreed make significant contributions through their own delivery as well as through requirements placed upon future tenants of the various uses. These comprise:
- Free tickets to borough residents for shows and events
 - Use of theatre space and back office rooms to local groups for free
 - Priority tickets to cinema and theatre to disabled residents
 - Future occupiers to engage with local schools and colleges to provide training opportunities

- Theatre and community space occupiers to engage with local groups, schools and colleges
- LBHF partnership with Yoo and occupier foundations to deliver council programmes

5.2.7. It is considered that the social and economic benefits derived from the development are substantial public benefits and represent the delivery of the council's spatial vision and strategic objectives set out within the Local Plan as well as representative of the opportunity the development of Olympia presents. Officers therefore consider that the proposal, subject to s106 legal agreement to secure the benefits identified and agreed, is in accordance with London Plan Policies 3.1 and 4.12 and Draft London Plan Policy E2 and Local Plan Policies E1 and E4.

5.3 Design, Heritage and Townscape

Design

5.3.1 **The NPPF** seeks to secure high quality design and a good standard of amenity for all existing and future occupants of land and buildings. The NPPF also requires that proposals should conserve heritage assets in a manner appropriate to their significance, so that they can be enjoyed for their contribution to the quality of life of this and future generations.

5.3.2 **The NPPF** states that good design is a key aspect of sustainable development, and should contribute positively to making places better for people. Part 12 of the NPPF outlines the requirement for good design and Paragraph 127 sets out that planning policies and decisions should ensure that developments:

- a) will function well and add to the overall quality of the area, not just for the short term but over the lifetime of the development;
- b) are visually attractive as a result of good architecture, layout and appropriate and effective landscaping;
- c) are sympathetic to local character and history, including the surrounding built environment and landscape setting, while not preventing or discouraging appropriate innovation or change (such as increased densities);
- d) establish or maintain a strong sense of place, using the arrangement of streets, spaces, building types and materials to create attractive, welcoming and distinctive places to live, work and visit;
- e) optimise the potential of the site to accommodate and sustain an appropriate amount and mix of development (including green and other public space) and support local facilities and transport networks; and
- f) create places that are safe, inclusive and accessible and which promote health and well-being, with a high standard of amenity for existing and future users; and where crime and disorder, and the fear of crime, do not undermine the quality of life or community cohesion and resilience.

5.3.3 Chapter 7 of **the London Plan** sets out the Mayor's policies on a range of issues regarding places and space, setting out fundamental principles for design. Policy 7.1 (Lifetime Neighbourhoods) states that the design of new buildings and the spaces they create should help reinforce or enhance the character, legibility, permeability, and accessibility of the neighbourhood. Policy

7.2 (An Inclusive Environment) requires all new development in London to achieve the highest standards of accessible and inclusive design. Policy 7.3 (Designing out crime) seeks to ensure that developments reduce the opportunities for criminal behaviour and contribute to a sense of security, without being overbearing or intimidating.

- 5.3.4 **Policies 7.4 (Local character), 7.5 (Public realm) and 7.6 (Architecture) of the London Plan** are all relevant and promote the high quality design of buildings and streets. Policy 7.4 states that development should have regard to the form and function, and structure of an area, place or street and the scale, mass, and orientation of surrounding buildings whilst Policy 7.6 states that buildings and structures should not cause unacceptable harm to the amenity of surrounding land and buildings.
- 5.3.5 **Policy 7.7 (Tall buildings)** states that tall and large buildings should generally be limited to sites in the Central Activity Zone, opportunity areas, areas of intensification or town centres that have good access to public transport; should only be considered in areas whose character would not be affected adversely by the scale, mass or bulk of a tall or large building; should relate well to the form, proportion, composition, scale and character of surrounding buildings, urban grain and public realm, improve the legibility of an area, by emphasising a point of civic or visual significance and enhance the skyline and image of London. They should also incorporate the highest standards of architecture and materials, including sustainable design and construction practices; should have ground floor activities that provide a positive relationship to the surrounding streets; should contribute to improving the permeability of the site and wider area; should incorporate publicly accessible areas on the upper floors and should make a significant contribution to local regeneration. Policy 7.8 (Heritage assets and archaeology) states that development affecting heritage assets and their setting should conserve their significance by being sympathetic to their form, scale, materials, and architectural detail.
- 5.3.6 **The Draft London Plan** seeks to secure the delivery of good design through a variety of ways. Going beyond the expectations of the adopted London Plan, **Draft Policy D2** does the following. Part C encourages use of digital modelling techniques to analyse potential design options, and to use 3D/virtual reality to inform and engage Londoners in the planning process. Part F requires proposals to go through a design review (which must align with the Mayor's guidance on design reviews) if a scheme is referable to the Mayor and is above the design threshold in **Draft Policy D6** or a tall building is proposed in an area where there is 'no local tall building definition'. Part H seeks to ensure design quality is retained through (inter alia) avoiding deferring the assessment of the design quality of large elements of a development to the consideration of a planning condition or referred matter, and the use of architect retention clauses in legal agreements 'where appropriate'.
- 5.3.7 **The Council's Local Plan Policies DC1, DC2 and DC3 are particularly relevant to the assessment of design.** DC1 (Built Environment) states that all development within the borough should create a high quality urban environment that respects and enhances its townscape context and heritage assets. There should be an approach to accessible and inclusive urban design that considers

how good design, quality public realm, landscaping and land use can be integrated to help regenerate places.

5.3.8 **Policy DC2 (Design of New Build)** sets out to ensure that new build development will be of a high standard of design and compatible with the scale and character of existing development and its setting.

5.3.9 **Policy DC3 (Tall Buildings)** states that:

Tall buildings, which are significantly higher than the general prevailing height of the surrounding townscape and which have a disruptive and harmful impact on the skyline, will be resisted by the council. However, areas where tall buildings may be appropriate are as follows:

- a). White City Regeneration Area;
- b). Earls Court & West Kensington Opportunity Area;
- c). South Fulham Riverside Regeneration Area; and
- d). Hammersmith Town Centre.

In these areas identified as potentially appropriate for tall buildings, any proposal will need to demonstrate that it:

- a). has a positive relationship to the surrounding townscape context in terms of scale, streetscape and built form;
- b). is of the highest quality of architectural design and materials with an appropriate form and silhouette which contributes positively to the built heritage and image of the borough;
- c). has an acceptable impact on the skyline, and views from and to open spaces, the riverside and waterways and other locally important views and prospects;
- d). has had full regard to the significance of heritage assets including the setting of, and views to and from, such assets, has no unacceptable harmful impacts, and should comply with Historic England guidance on tall buildings;
- e). is supported by appropriate transport infrastructure;
- f). has an appropriate design at the base of the tall building and provides ground floor activity;
- g). interacts positively to the public realm and contributes to the permeability of the area;
- h). is of a sustainable design and constructions, including minimising energy use and the risk of overheating through passive design measures, and the design allows for adaption of the space;
- i). does not have a detrimental impact on the local environment in terms of microclimate, overshadowing, light spillage and vehicle movements; and
- j.) respects the principles of accessible and inclusive urban design.

Design Character of Proposals

Grand Hall

5.3.10 The Grand Hall would be retained in use as an exhibition hall, with the insertion of two new mezzanine levels at the west end. The lower mezzanine would be installed at the level of the existing gallery and would occupy the four westernmost bays of the historic barrel vault structure, representing approximately a third of the space. The existing balustrade around the gallery at the western end would be removed to allow for free flow of visitors between

the existing gallery and the lower mezzanine level. This would enable more efficient use of the existing gallery level at Grand Hall which is awkwardly configured in plan form and lacks significant depth, resulting in poor pedestrian flow and limitations on how it can be used by exhibitors during exhibitions. It would also allow for a permanent expansion of exhibition floor space within Grand Hall, which is the preferred location for many exhibitors, supporting and sustaining the core exhibition business. Existing arrangements for larger exhibitions in Grand Hall involve the construction of temporary mezzanine levels accessed from the gallery and by temporary staircases from the main exhibition hall below. These arrangements provide a poor quality environment for exhibitors and visitors, in contrast with the grandeur of the original Grade II* exhibition hall.

- 5.3.11 The upper level mezzanine would be designed to provide new food and beverage facilities in order to enhance the current offer available to exhibitors and visitors. It would be smaller in floor area than the lower level mezzanine, occupying two bays. It would be set in at the sides and at the front to create a tiered appearance. A simply detailed and lightweight connection also would be provided between the upper level mezzanine and the sky-deck between Grand Hall and National Hall, this will require the removal of small sections of metal panels to the barrel vaulted roof of Grand Hall to create a double door.
- 5.3.12 The extent of the mezzanine proposals has been reduced through the pre-application process and the original design has been significantly revised. The detailed design and materials of the mezzanine levels have also been revised through the pre-application process and the decorative steel supports reflect the original architecture of the gallery level supports and the roof structure.
- 5.3.13 Lifts and stair access would be provided to the mezzanine levels in two separate cores rising from the main exhibition floorspace at ground floor level. Access to the existing gallery level would also be improved by the insertion of escalators between ground and first floor levels on the north side of the Grand Hall, which will require the removal of two bracing beams at ground floor and one bracing beam at mezzanine level and their replacement with a lightweight structure. New lifts between basement level and gallery level would also be provided on the south side of the Grand Hall.
- 5.3.14 The existing single storey buildings on the forecourt of Grand Hall fronting Olympia Way, some of which date from 1936, would be demolished. The original entrance at ground floor level on the front elevation of Grand Hall within the triumphal arch would be reinstated including stone columns and timber entrance doors. The front elevation of Grand Hall would also be restored by the removal of the existing external staircase to first floor level, the reinstatement of the bas relief within the arch and the reinstatement of the sculpture of Britannia surmounting the arch.

Pillar Hall

- 5.3.15 Pillar Hall has been poorly utilised over the past decade, especially the galleried first floor hall. Listed Building Consent has previously been granted to convert the first floor hall to ancillary office use for the exhibition centre, involving the insertion of a mezzanine level, but this has not materialised. The

building would be refurbished in connection with a change of use from exhibition centre to a restaurant/bar with live music. A lift access would be provided to improve access to the first and second floors. Externally the modern metal canopy would be removed from above the front entrance door and the existing steps would be replaced by level access from the proposed public realm on Olympia Way.

National Hall

- 5.3.16 The exhibition hall at National Hall would be retained in use for exhibitions, with the insertion of two new mezzanine levels at the west end. The lower mezzanine would be installed at the level of the existing gallery and would occupy the three westernmost bays of the historic barrel vault structure, out of a total of seven bays. The existing balustrade around the gallery at the western end would be removed to allow for free flow of visitors between the existing gallery and the lower mezzanine level. This would enable more efficient use of the existing gallery level at National Hall which is awkwardly configured in plan form and lacks significant depth, resulting in poor pedestrian flow and limitations on how it can be used by exhibitors during exhibitions. It would also allow for a permanent expansion of exhibition floor space within National Hall, sustaining the core exhibition business.
- 5.3.17 The upper level mezzanine would be designed as a multi-space which could operate as exhibition floorspace or to provide new food and beverage facilities in order to enhance the current offer available to exhibitors and visitors. It would be smaller in floor area than the lower level mezzanine, occupying two bays. It would be set in at the sides and at the front, in order to create a tiered appearance. A connection also would be provided between the upper level mezzanine and the north-south section of the Level 2 sky-deck, this will require the removal of a small section of the west screen to National Hall.
- 5.3.18 The extent of the mezzanine proposals has been reduced through the pre-application process and the original design has been significantly revised. The detailed design and materials of the mezzanine levels have also been revised through the pre-application process and the decorative steel supports reflect the original architecture of the gallery level supports and the roof structure. The design and materials of the mezzanines will also match those of the mezzanines in the Grand Hall. Lifts and stair access would be provided to the mezzanine levels in two separate cores rising from the main exhibition floorspace at ground floor level.
- 5.3.19 The southern wing of National Hall which contains the Pizza Express restaurant at ground floor level, the Apex and Club Rooms at first floor level and ancillary facilities would be converted to use as a 123 bedroom hotel, in connection with the erection of part two, part three storey extension at roof level. The Pizza Express restaurant, the Apex Room and Club Rooms would be reused for larger public spaces within the hotel including reception, bar and restaurant facilities. New columns would be inserted through the building in order to support the weight of the hotel extension. The new columns would be visible within Pizza Express restaurant, the Apex and Club Rooms.

5.3.20 Externally the additional floors for hotel bedrooms would have a contemporary appearance consisting of stepped and angled zinc clad vertical window bays. These create a roof form, with a more solid appearance from the east and a more glazed appearance from the west. The internal floor slab is not expressed externally, so as not to compete with the horizontal emphasis of the National Hall facades to Hammersmith Road and Olympia Way. The massing of the hotel extension has been reduced during the pre-application process and the initial design has been significantly revised. The existing roller shutter for vehicular access at ground floor level fronting Olympia Way would be removed and the original entrance to National Hall reinstated.

Level 2 Sky Deck (L2)

5.3.21 The brick infill block between Grand Hall and National Hall above B Gate, fronting Olympia Way, would be demolished and the return elevations of Grand Hall and National Hall would be reinstated. At roof level the existing plant would be removed. A sky deck would be built at second floor level in order to provide greater permeability through the site, new public realm and retail uses and a means of access to the office accommodation within the redeveloped Olympia Central, the live music venue above West Hall and the theatre on the G-Gate site. A bank of escalators would lead up from Olympia Way to the sky deck concourse between Grand Hall and National Hall. The concourse would incorporate retail units and landscaping and would be partially enclosed by a curved glazed canopy set between the barrel vault roofs of Grand Hall and National Hall. In order to provide structural support to the sky deck it will be necessary to insert columns through the roofs and decks of the gallery spaces in Grand Hall and National Hall, down to ground floor level. New plant would be accommodated in the void beneath the sky deck.

5.3.22 Further west, the concourse on the sky deck would extend into public realm named Central Avenue, which would run beneath the proposed office element in the redeveloped Olympia Central. Central Avenue would incorporate links into the upper mezzanine levels at Grand Hall and National Hall. The underside of the office element of the redeveloped Olympia Central would be enlivened by a sculpted soffit with a lighting scheme. From Central Avenue there would be open views across to the west screen and barrel vaulted roof of Grand Hall. Central Avenue would continue on to the G-Gate staircase set between the redeveloped Olympia Central and the theatre on the G-Gate site, which would lead down to Hammersmith Road. The new public realm will provide a pedestrian friendly and accessible route from the junction of Hammersmith Road and North End Road to Olympia Way and Kensington Olympia Station, providing an alternative to walking along Hammersmith Road.

5.3.23 The detailed design of the Level 2 sky deck has been significantly revised through the pre-application process, including the omission of a projecting circular walkway over Olympia Way.

Olympia Central

5.3.24 The existing exhibition hall at Olympia Central would be demolished behind the 1930s façade, which would be retained. The demolition would enable the provision of Logistics Centre at ground floor level and over two new basement

level. Replacement exhibition and conference floorspace would be erected behind the retained façade. The front elevation of Olympia Central would be enlivened with new shop units lining the Hammersmith Road frontage utilising existing openings. The new exhibition floorspace would be connected to the at first floor level to the existing exhibition floorspace in Grand Hall and National Hall and would have an independent access through a monumental portal in the western flank wall accessed from the G-Gate staircase.

- 5.3.25 The original '1929' relief would be reinstated below the existing 'OLYMPIA' relief. It is proposed to remove the existing paint from the façade and restore the original concrete. The existing windows would be replaced with double glazed metal windows, details of which would be subject to a condition.
- 5.3.26 Above the new exhibition and conference floorspace and set back from the Hammersmith Road frontage, an office building would be erected in a series of five tiered 'fingers', the middle of which would rise to 10 storeys in the centre of the site. The fourth and fifth 'fingers' of the office element would then step down towards to the north. At the rear, part of the office element would cantilever out over the southern gallery of Grand Hall. The curved form of each end of the 'fingers' and the tiered plan form would help to break up the massing and provide a series of narrow elevations in the view from RBKC and Addison Bridge, where it would be seen in conjunction with the Grand Hall and National Hall. The curtain walling of the office floors would incorporate pleated glazing as a reference to the design of the glazing in the east screen of Grand Hall. Every other floor slab would be expressed through horizontal banding, creating two storey high glazed bands which would create a sense of generous proportions. The office element would be accessed from the Level 2 sky deck.
- 5.3.27 The height and massing of the office element of the scheme has been significantly reduced through the pre-application process. Two massing options were presented at a public consultation and the submitted scheme was generally preferred to a lower rise option that brought the massing closer to the Hammersmith Road frontage.

G-Gate

- 5.3.28 The existing vehicle parking area on the vacant G-Gate site would be redeveloped to provide a new theatre rising to 58m in height. The building would be designed to meet the requirements of the Logistics Centre beneath it and the requirements of the theatre use. At the base of the theatre fronting Hammersmith Road there would be a significant cantilever, which would project out over a public arcade activated by a double height retail unit and over part of the monumental G-Gate staircase leading up to Central Avenue and the Level 2 sky deck. The cantilever would be supported by metal columns which would extend up the façade of the building, breaking it into separate vertical bays, providing a strong vertical emphasis. The building would be constructed of textured concrete, reflecting the materiality of the adjacent Olympia Central façade and providing opportunities to incorporate relief through gradations of colour and texture. The building would provide a landmark at an important corner on the Olympia site and would hold its own against the horizontal emphasis of the Olympia Central facade. It has previously been established through the public inquiry process for a previous redevelopment scheme on the G-Gate site that any new building should be taller than the existing Olympia

Central façade. The pedestrian entrance to the theatre would be from Central Avenue and the Level 2 sky deck.

West Hall

- 5.3.29 The predominantly modern West Hall would be extended upwards by two floors to create a live music venue accessed from the Level 2 public realm. The serrated plan form of the extension would reflect the curve of Blythe Road and would break up the massing into legible vertical bays addressing the street. The extension would be clad in a bronze coloured metal mesh screen incorporating a diamond motif. At roof level the individual bays would have a pleated roof form to create visual interest. The extension would be set away from the west screen of Grand Hall by around 15m.
- 5.3.30 The existing exhibition halls at ground and first floor levels within West Hall would be retained in exhibition use. The existing first floor level elevation would be reclad with a metal mesh screen to create a consistent appearance with the elevation of the music venue extension above. The original brick wall to the former Victorian stables fronting Blythe Road, which has been patch repaired in the past, would be subject to remedial works to improve its visual appearance.

Maclise Road MSCP

- 5.3.31 The existing Multi-Storey Car Park with its split floor levels would be substantially redeveloped to provide a 211 bedroom hotel at the eastern end and offices at the western end. The retained element of the structure would be towards Maclise Road, with the southern parking decks and the stair tower on Olympia Way being demolished to create level floorplates and a new entrance for the hotel from Olympia Way. Two additional floors would be erected at roof level to form a lightweight glazed element. The basement level would be excavated by one storey to allow for the provision of a cinema.
- 5.3.32 The façade to the retained structure will be replaced with a curved glass and brick elevation in a similar style to the existing. The new build element fronting Olympia Way will be treated as an expressive architectural façade, adopting a series of curved glass and brick bays that produce a vertical emphasis to the building and a feature to terminate the view at the north end of Olympia Way.
- 5.3.33 The hotel reception and restaurant would provide an active frontage at ground floor level to the corner of Olympia Way and Maclise Road. Further west along Maclise Road, the office entrance would also provide animation to the street frontage.
- 5.3.34 Internally, the western spiral car park ramps would be incorporated into the office building.

L-Yard

- 5.3.35 L-Yard currently functions as the location for existing plant and servicing activities. It is dominated by the flank walls of surrounding buildings and by the brick chimney. As a typical back of house space, it has a generally poor quality of appearance and there are views into it from the public highway on Blythe

Road. The proposals involve the erection of an energy centre and a new 48m high flue to service it.

Olympia Way

- 5.3.36 The associated proposals under application ref. 2018/03102/OUT involve improvements to the public realm along Olympia Way, in conjunction with the removal of the single storey buildings from in front of Grand Hall and the vehicle crossovers to National Hall and B-Gate.

Design Review Panel

- 5.3.37 The scheme was presented to the Council's Design Review Panel in August 2018. The Panel welcomed the applicant's desire to reinvigorate the estate and acknowledged that Olympia is a real asset both locally and for London. The headlines of the masterplan to declutter and open the site by improving the public realm were seen as a good basis for the design.
- 5.3.38 In their assessment of the various elements of the scheme. The Panel raised the following key issues.
- The Panel considered that the core of the masterplan is the weakest part with the central space needing a stronger identity to provide an attraction and to hold the scheme together. As currently proposed, the Panel felt that the journey into the site loses momentum at the top of the escalator. The detail of the route needs further development, so it can be demonstrated that there are beneficial improvements to permeability across the site, The Panel considered that varying architectural expressions may work better if the central space was strong enough to support this approach, and allow the buildings to "hang off" it.
 - The Panel thought that most of the new buildings on the masterplan appear to be fighting for attention, and challenging the presence of the listed buildings, and suggested that there should be places for calmer "background buildings" allowing those key buildings both existing and proposed to be prominent.
- 5.3.39 The Panel were concerned with the relationship of the scale and massing of the new extensions in relation to the listed buildings, and found that the relative importance assigned to the buildings both existing and new does not come across in the masterplan. The Panel acknowledged that it is a very complex but most worthwhile project. The overriding aims to allow the exhibition function to flourish amongst new cultural offers and thereby begin to create a new district with a new sense of place was fully supported.
- 5.3.40 The applicant has responded to the Design Review Panel's comments stating that the Level 2 public realm is strong enough to bring the varying styles of the existing heritage buildings and modern interventions together and that each of the extensions to National Hall, Olympia Central and the MSCP have been specifically designed in response to the host buildings. The applicant also believes that the scheme is a well conceived balanced response that respects the heritage fabric of the estate.

Design Conclusion

- 5.3.41 The proposals are the result of comprehensive, masterplan approach the site which represents the best approach to future development on the site. The proposed buildings and extensions to existing buildings would represent a high quality of design and materials, with each building having its own character. The proposals are informed by an understanding of the significance of the heritage assets affected and the detailed design of the individual elements is considered compatible with the adjacent listed buildings.
- 5.3.42 The proposed Central Workspace building over Olympia Central would be the tallest building on the site and would rise to 73m. The proposed form and composition of the building would relate to the large scale buildings and urban grain of the Olympia estate and is considered to be of an appropriate high-quality design. The building would be set back from the retained listed façade on the street frontage with its tallest section set towards the centre of the site. It would connect positively to the new raised public realm. The building would have no unacceptable harmful impacts on the setting of surrounding heritage asserts where any harm identified has been assessed as substantial in magnitude. The GLA support the proposed massing and have found the scale in accordance with the Tall Buildings policy in the London Plan. The Council's Local Plan policy directs the location of tall buildings to regeneration areas and Hammersmith Town Centre, in order that they can contribute in a positive manner to enhance a sense of place. Officers consider that the proposed Central Workspace building would perform a similar role at Olympia, improving the legibility of the estate, enhancing the image of Olympia, and taking on an appropriate landmark role as part of the development securing the long term future of the exhibition centre. In this instance it is found to address the criteria in both the London Plan and the council's Tall Buildings policy.
- 5.3.43 The new buildings are significant additions in terms of height and massing and will follow the tradition of large buildings on the Olympia site. The proposals would represent a further evolution of development at Olympia and would add to the rich variety of architectural styles and materials on the site. Inevitably buildings of this scale will have impacts which are discussed in the Heritage impacts section of this report. The proposals would also deliver well designed public realm around and through the site, improving permeability and would increase the extent of active frontages around the perimeter of the site, improving the visual relationship with the streetscene.

Heritage

- 5.3.44 **The Planning (Listed Buildings and Conservation Areas) Act 1990** sets out the principal statutory duties which must be considered in the determination of any application affecting listed buildings or conservation areas.
- 5.3.45 It is key to the assessment of these applications that the decision making process is based on the understanding of specific duties in relation to listed buildings and Conservation Areas required by the relevant legislation, particularly the s.16, s.66 and s.72 duties of the Planning (Listed Buildings and Conservation Areas) Act 1990 and the requirements set out in the NPPF.

- 5.3.46 s16(2) of the Planning (Listed Buildings and Conservation Areas) Act 1990 states in relation to listed buildings that:
- 5.3.47 'In considering whether to grant listed building consent for any works, the local planning authority or the Secretary of State shall have special regard to the desirability of preserving the [listed] building or its setting or any features of special architectural or historic interest which it possesses.'
- 5.3.48 A similar duty in s66 of the Planning (Listed Buildings and Conservation Areas) Act 1990 requires that:
- 5.3.49 'In considering whether to grant planning permission for development which affects a listed building or its setting, the local planning authority or, as the case may be, the Secretary of State shall have special regard to the desirability of preserving the building or its setting or any features of special architectural or historic interest which it possesses.'
- 5.3.50 s72 of the above Act states in relation to Conservation Areas that:
- 5.3.51 'In the exercise, with respect to any buildings or other land in a conservation area, of any functions under or by virtue of any of the provisions mentioned in subsection (2), special attention shall be paid to the desirability of preserving or enhancing the character or appearance of that area.'
- 5.3.52 **Paragraph 184 of the NPPF** states:
- 5.3.53 Heritage assets range from sites and buildings of local historic value to those of the highest significance, such as World Heritage Sites which are internationally recognised to of Outstanding Universal Value. These assets are an irreplaceable resource, and should be conserved in a manner appropriate to their significance, so that they can be enjoyed for their contribution to the quality of life of existing and future generations.
- 5.3.54 **Paragraph 190 of the NPPF** states:
- 5.3.55 Local Planning Authorities should identify and assess the particular significance of any heritage asset that may be affected by a proposal (including by development affecting the setting of a heritage asset) taking account of the available evidence and any necessary expertise. They should take this into account when considering the impact of a proposal on a heritage asset, to avoid or minimise any conflict between the heritage asset's conservation and any aspect of the proposal.
- 5.3.56 **Paragraph 192 of the NPPF** states:
- 5.3.57 In determining applications, local planning authorities should take account of:
- a) the desirability of sustaining and enhancing the significance of heritage assets and putting them to viable uses consistent with their conservation;
 - b) the positive contribution that conservation of heritage assets can make to sustainable communities including their economic vitality; and

c) the desirability of new development making a positive contribution to local character and distinctiveness.

5.3.58 **Paragraph 193 of the NPPF** states:

5.3.59 When considering the impact of a proposed development on the significance of a designated heritage asset, great weight should be given to the asset's conservation (and the more important the asset, the greater the weight should be). This is irrespective of whether any potential harm amounts to substantial harm, total loss or less than substantial harm to its significance.

5.3.60 **Paragraph 194 of the NPPF** states that any harm to, or loss of, the significance of a designated heritage asset (from its alteration or destruction, or from development within its setting), should require clear and convincing justification. Substantial harm to or loss of:

a) grade II listed buildings, or grade II registered parks or gardens, should be exceptional;

b) assets of the highest significance, notably scheduled monuments, protected wreck sites, registered battlefields, grade I and II* listed buildings, grade I and II* registered parks and gardens, and World Heritage Sites, should be wholly exceptional.

5.3.61 **Paragraph 195 of the NPPF** states that where a proposed development will lead to substantial harm to (or total loss of significance of) a designated heritage asset, local planning authorities should refuse consent, unless it can be demonstrated that the substantial harm or total loss is necessary to achieve substantial public benefits that outweigh that harm or loss, or all of the following apply:

a) the nature of the heritage asset prevents all reasonable uses of the site; and

b) no viable use of the heritage asset itself can be found in the medium term through appropriate marketing that will enable its conservation; and

c) conservation by grant-funding or some form of not for profit, charitable or public ownership is demonstrably not possible; and

d) the harm or loss is outweighed by the benefit of bringing the site back into use.

5.3.62 **Paragraph 196 of the NPPF** states:

5.3.63 Where a development proposal will lead to less than substantial harm to the significance of a designated heritage asset, this harm should be weighed against the public benefits of the proposal including, where appropriate, securing its optimum viable use.

5.3.64 The NPPF makes a clear distinction between the approach to be taken in decision-making where the proposed development would affect the significance of designated heritage assets (listed buildings, conservation areas, Registered Parks and Gardens) and where it would affect the significance of non-designated heritage assets (buildings of local historic and architectural importance).

- 5.3.65 The NPPF also makes a clear distinction between the approach to be taken in decision-making where the proposed development would result in 'substantial' harm and where it would result in 'less than substantial' harm.
- 5.3.66 Case law indicates that following the approach set out in the NPPF will normally be enough to satisfy the statutory tests. However, when carrying out the balancing exercise in paragraphs 195 and 196, it is important to recognise that the statutory provisions require the decision maker to give great weight to the desirability of preserving designated heritage assets and/or their setting.
- 5.3.67 The Planning Practice Guidance notes which accompany the NPPF remind us that it is the degree of harm to the asset's significance rather than the scale of the development that is to be assessed.
- 5.3.68 The scheme would impact both directly and indirectly on heritage assets. These impacts are considered separately in the following sections.
- 5.3.69 For the indirect impacts, namely impacts on settings, officers agreed areas for assessment with the applicants. The applicant's statement submitted with the application seeks to identify the significance of designated heritage assets within a study area of 750m surrounding the site, including designated heritage assets in Hammersmith & Fulham and RBKC. It identifies designated assets that have a connection to the proposed development area and seeks to identify the significance of the designated heritage asset in relation to the site.
- 5.3.70 In the first instance, the assessment to be made is whether the development within the setting of a designated heritage asset will cause harm to that designated heritage asset or its setting. If no harm is caused, there is no need to undertake a balancing exercise. If harm would be caused, it is necessary to assess the magnitude of that harm before going to apply the balancing test as set out in paragraphs 195 and 196 of the NPPF as appropriate.
- 5.3.71 **Local Plan Policy DC8** (heritage and conservation) states that the council will conserve the significance of the borough's historic environment by protecting, restoring and enhancing its heritage assets. These assets include: listed buildings, conservation areas historic parks and gardens, the scheduled monument of Fulham Palace Moated site, unscheduled archaeological remains and buildings and features of local interest. When determining applications affecting heritage assets, the council will apply the following principles:
- a. the presumption will be in favour of the conservation, restoration and enhancement of heritage assets, and proposals should secure the long term future of heritage assets. The more significant the designated heritage asset, the greater the presumption should be in favour of its conservation;
 - b. applications affecting designated heritage assets, including alterations and extensions to buildings will only be permitted if the significance of the heritage asset is conserved or enhanced;
 - c. applications should conserve the setting of, make a positive contribution to, or reveal the significance of the heritage asset. The presence of heritage assets should inform high quality design within their setting;
 - d. applications affecting non-designated heritage assets (buildings and artefacts of local importance and interest) will be determined having regard to

the scale and impact of any harm or loss and the significance of the heritage asset in accordance with paragraph 135 of the National planning Policy Framework;

e. particular regard will be given to matters of scale, height, massing, alignment, materials and use;

f. where changes of use are proposed for heritage assets, the proposed use, and any alterations that are required resulting from the proposed use should be consistent with the aims of conservation of the asset's significance, including securing its optimum viable use;

g. applications should include a description of the significance of the asset concerned and an assessment of the impact of the proposal upon it or its setting which should be carried out with the assistance of a suitably qualified person. The extent of the requirement should be proportionate to the nature and level of the asset's significance. Where archaeological remains of national significance may be affected applications should also be supported by an archaeological field evaluation;

h. proposals which involve substantial harm, or less than substantial harm to the significance of a heritage asset will be refused unless it can be demonstrated that they meet the criteria specified in paragraph 133 and 134 of the National Planning Policy Framework;

i. where a heritage asset cannot be retained in its entirety or when a change of use is proposed, the developer should ensure that a suitably qualified person carries out an analysis (including photographic surveys) of its design and significance, in order to record and advance the understanding of heritage in the borough. The extent of the requirement should be proportionate to the nature and level of the asset's significance;

j. the proposal respects the principles of accessible and inclusive design;

k. where measures to mitigate the effects of climate change are proposed, the applicants will be required to demonstrate how they have considered the significance of the heritage asset and tailored their proposals accordingly;

l. expert advice will be required to address the need to evaluate and conserve archaeological remains, and to advise on the appropriate mitigation measures in cases where excavation is justified; and

m. securing the future of heritage assets at risk identified on Historic England's national register, as part of a positive strategy for the historic environment.

5.3.72 **The Council's Supplementary Planning Guidance SPD** is relevant, in particular Key Principles AH1 (Information Requirements for applications for consent affecting heritage assets); AH2 (Protection of Heritage Assets); CAG1 (Land Use in Conservation Areas); CAG2 (Urban Design in Conservation Areas); CAG3 (New Development in Conservation Areas) and BL2 (Lightwells and Basement Excavation relating to listed buildings). These Key Principles provide guidance which seeks to ensure that heritage assets are conserved in a manner appropriate to their significance in accordance with the NPPF.

Impacts on Heritage Assets

5.3.73 As summarised above, the NPPF requires local authorities to conserve heritage assets in a manner appropriate to their significance. The more important the asset, the greater the weight that should be given to its conservation. National Policy does not preclude development of heritage assets or development which

may affect them or their setting, but aims to put in place the requirement for a considered analysis of when and where this may be acceptable.

5.3.74 The conservation areas, both within and surrounding the site, would be impacted upon both directly and indirectly. For those heritage assets surrounding the site, this is assessed in more detail in the following Townscape Assessment in terms of the impact on views. Those heritage assets further from the site would be subject to low or no impacts resulting from the proposed development. The townscape assessment therefore confines itself to impact studies on the surrounding heritage assets.

5.3.75 The following heritage assets are considered in the analysis:

5.3.76 The site includes the following listed buildings:

- Grand Hall and Pillar Hall (Grade II*, 1885)
- National Hall and Olympia Central (Grade II, 1923 and 1929)
- Olympia Multi-Storey Car Park (Grade II, 1935-7)

5.3.77 The site is located within the Olympia and Avonmore Conservation Area.

5.3.78 The Adjacent heritage assets affected by the proposals in Hammersmith and Fulham include:

- Blythe House (Grade II listed in part)
- West Kensington Post Office and Delivery Office (Grade II listed)
- Lakeside/Sinclair/Blythe Road Conservation Area
- Brook Green Conservation Area
- Dorcas Estate Conservation Area
- Fitzgeorge and Fitzjames Conservation Area

5.3.79 Adjacent heritage assets affected by the proposals in the Royal Borough of Kensington and Chelsea include:

- Holland Park Conservation Area
- Edwardes Square/Scarsdale Conservation Area
- Holland Park Registered Park and Garden

Townscape Assessment – Visual Impact Analysis

5.3.80 In total, the applicants have tested 21 key townscape views around the site, 6 of which fall within the Royal Borough of Kensington and Chelsea.

Key Views from the South (nos.4,5,6,19,20,21)

5.3.81 6 of these views lay broadly to the south of the Olympia Complex comprising 3 close range views from within the Olympia and Avonmore Conservation Area and 3 longer range views from Margravine Cemetery, Brompton Cemetery, and Hammersmith Embankment. The study showed that the proposal would not be visible from the 3 longer range views. Of the closer range views,

5.3.82 There is an important view from North End Road into the Olympia and Avonmore Conservation Area which features the Former Courthouse (Grade II)

on the east side of the street and other high quality Victorian buildings. The Central Workspace Building would appear in the backdrop to the courthouse and the G-Gate Theatre would appear at the termination point where North End Road meets Hammersmith Road. It is considered that the Victorian Buildings in the foreground including the former Courthouse, will remain legible against the proposed glazed elevations, and the setting of the Courthouse will be preserved.

- 5.3.83 The proposed G Gate Theatre would have a significant presence in these views. The blank façade, which is unrelieved by fenestration, but which would be modelled and detailed, will demand careful consideration during the design development phase to ensure that it has an appropriate level of visual interest to address the view. This building would dominate the view by way of its scale and façade design and Officers consider that it would cause some harm to the character and appearance of the Olympia and Avonmore Conservation Area.

Key View from the West (nos.3,9,10,11,13)

- 5.3.84 5 key views have been assessed that lay broadly to the west of the proposal. These are all relatively close-up views from within the Brook Green, Olympia and Avonmore and Lakeside Sinclair Blythe Conservation Areas.
- 5.3.85 From the view in Brook Green, the proposal is demonstrated to be not visible. From the key view on Blythe Road (South) the proposed development will add additional built form above the retained curved elevation of the West Hall. Officers consider that the increased height will provide a balance to the buildings on the opposite side of the street and will enhance the legibility and definition of scale to the street.
- 5.3.86 From the key view on Blythe Road (North West), the new massing of the Central Workspace Building will be visible within the setting of the Post Office Savings Building, rising higher behind it. Officers consider that it will add visual interest to the view due to the distinctive quality of the architecture. However, the glazing will have the negative effect of obscuring the distinct form of the cupolas on the skyline. Officers consider that the balance of the effects on the setting of the listed building is that some harm [less than substantial] would result to both the listed building and the conservation area.
- 5.3.87 There are 2 views from Hammersmith Road which both look into the Olympia and Avonmore Conservation Area. The more distant view is from the junction with Auriol Road. In this view, the scale and massing of buildings above the National Hall (Grade II) would achieve a comfortable relationship of scale across Hammersmith Road. However, the positive effect, is tempered by the proposed height of the G Gate Theatre and the Central Workspace building. Officers agree with the applicant's assessment that the proposal will reinforce the linearity of the route, however, the scale and massing of the proposed G-Gate Theatre and Central Workspace building will exceed what is required to improve the definition of the route.
- 5.3.88 The closer range view is from east of the junction with Southcombe Street, within the Dorcas Estate Conservation Area. Officers consider that from this view, the scale and massing of the proposed development will have a harmful

impact on the setting of the Olympia Central (Grade II*) and the character and appearance of the Olympia and Avonmore Conservation Area.

- 5.3.89 The proposed roof form of the hotel above the National Hall (Grade II) adds visual interest to the roofline and maintains a comfortable relationship of scale with the Victorian Buildings opposite on Hammersmith Road. Whilst the new Central Workspace on top of Olympia Central (Grade II) would add visual interest through the distinctive nature of its architecture, it would be dominant in scale in relation to both the street and Olympia Central. The level of harm is considered to be less than substantial harm.
- 5.3.90 The theatre building on G Gate also adds visual interest by way of its form and concrete façade with decorative relief panels. However, it also dominates the view within the setting of the Olympia Central and as such its effect is of less than substantial harm.

Key Views from the North (nos. 12,14)

- 5.3.91 Two views from the north have been assessed and they are both relatively close-range views from within the Lakeside Sinclair Blythe Conservation Area.
- 5.3.92 From the Blythe Road view, the proposal will appear in the backdrop to the barrel-vaulted roof of the Grand Hall (Grade II*). Officers consider that it would not dilute the ability to appreciate the historic elements.
- 5.3.93 Currently in the view from Sinclair Road, the barrel-vaulted roof of the Grand Hall (Grade II*), which is taller than the terraces in Sinclair Road, recedes away from the street due to its vaulted form and it's set back position. Although highly visible, the vaulted roof does not dominate the view, or detract from the setting of the Lakeside Sinclair Blythe Conservation Area from where it forms a local landmark, outside of the conservation area. The proposed hotel on the Maclise Road Car Park (Grade II) will span the full width of the termination point of the view and will be more prominent due to its width and height and its position close to the plot edge. It will appear higher than the Grand Hall vaulted roof, which would be screened from view. The proposed hotel would draw the eye away from the Victorian terraces in Sinclair Road. In so doing it will cause some harm to the setting of the Conservation Area, albeit of less than substantial harm.
- 5.3.94 Although the Central Workspace building will be apparent in the view, its mass will be offset from the axis of Sinclair Road and set behind the existing terraced housing and is considered to have a neutral effect that will not harm the setting of the Conservation area.

Key Views from the East (nos. 1,2,7,8,15,16,17,18)

- 5.3.95 8 views have been assessed that lay to the east of the Olympia Complex. 5 of these are relatively close to the site and 3 are more distant. 5 views are from within the Royal Borough of Kensington and Chelsea. In 4 of the views from RBKC the scheme will not be visible or will only be partially visible with a negligible impact.

- 5.3.96 Currently, the view of the vaulted roof of the National Hall (Grade II) is enjoyed as part of a pleasing composition with the vaulted roof of the Grand Hall (Grade II*) and these, form a local landmark. The proposed hotel on top of the National Hall would obscure the view of the barrel-vaulted roof from the view and part of its glazed arch façade. This would result in less than substantial harm to the National Hall and, due to its close proximity, less than substantial harm to the setting of the Grand Hall.
- 5.3.97 The massing of the stepped towers of the Central Workspace and their overall height would signal a distinct transition in scale from the lower Art Deco façade of Olympia Central (Grade II) and from the much lower height of the National Hall with the proposed hotel on top. This would result in less than substantial harm to the setting of both, of these Listed buildings.
- 5.3.98 The Central Workspace building would also compete for landmark status within the setting of the Grand Hall's vaulted roof This would result in less than substantial harm to the listed Grand Hall. In addition to the impacts on the individual listed buildings on the site, the development would cause some harm to the character and appearance of the Olympia and Avonmore Conservation Area.
- 5.3.99 Along Olympia Way, 2 views have been assessed. In the view from Hammersmith Road, Officers agree with the applicants that the new set back massing behind the parapet of the National Hall (Grade II) and the zinc clad structure will add an interesting roofline.
- 5.3.100 The proposals for the Maclise Road Car Park (Grade II), will introduce a high quality architectural feature at the end of Olympia Way. It will replace the façade of car park and potentially add more visual interest that could enhance the view and the setting of The Grand Hall (Grade II*) and the National Hall (Grade II).
- 5.3.101 The removal of the single storey entrance buildings along Olympia Way, would make a positive contribution to the visual amenity as the historic facades will be revealed. This will significantly enhance the special architectural interest of the Grand Hall (Grade II*).
- 5.3.102 In both views along Olympia Way, removing traffic, and re-landscaping the street are considered to be positive moves that help to improve the setting of the Grand Hall and National Hall that would improve the legibility of the street. In this respect, the proposals are considered to enhance the character and appearance of the Olympia and Avonmore Conservation Area.

Townscape Assessment – Summary

- 5.3.103 Officers conclude that there will be no significant adverse effect where the proposed development is considered to cause substantial harm to any of the surrounding heritage assets. It is inevitable that any development seeking to increase the use of the Olympia estate would have some impact on the surrounding heritage assets.

- 5.3.104 These townscape and heritage benefits of the wider masterplan need to be weighed against any harmful impacts identified in the Townscape Assessment. Officers have undertaken a balanced judgement on the scale of the harm caused, and are mindful of Government advice that it is the scale of harm rather than the scale of the proposal that is to be assessed in this judgement.
- 5.3.105 The concerns highlighted in the study relate to the degree of harm caused by the proposed increase in scale of the new additions, and the indirect impacts they have on the setting of the heritage assets. Officers have explored alternative design solutions with the applicants. The applicants have, during the design development, revised the design to reduce the height of the proposed additions as much as possible while still meeting the brief.
- 5.3.106 In summary, following an assessment of the Townscape Views Analysis, it is considered that the proposed development would cause either no harm or less than substantial harm to the heritage assets identified.
- 5.3.107 Where there is less than substantial harm, it should be given considerable weight in the planning decision process and there is a presumption against the grant of planning permission. The NPPF recognises that a balance needs to be struck between the preservation of the significance of a heritage asset and delivering public benefit. In this instance it is considered that any low or medium adverse impact the proposal may have in individual views the level of harm identified is outweighed by the public benefits the scheme would bring.

Significance of Heritage Assets

Olympia site overall

- 5.3.108 The Olympia Exhibition Centre is a visual and entertainment landmark of national significance which is well-known for its annual round of events. It is characterised by a variety of high quality buildings ranging in date from 1885 to the 1930s, designed for the purpose of hosting entertainments, events and exhibitions. The listed buildings at Olympia have considerable group value as part of an evolving complex of exhibition buildings on the site, which relate closely to each other functionally. Olympia also has substantial historical and communal significance as a major national and indeed international events space, reflecting the original vision of a foremost destination for large-scale entertainments and events, and the exhibition of art, science, and industry.
- 5.3.109 Olympia is a nationally rare building type of which there are few comparable examples. The structure of the Grand Hall has parallels with Victorian railway architecture, such as the impressive barrel vaulted roofs at Paddington and St Pancras railway stations, but is unusual for being deployed in exhibition and entertainment use and surviving substantially intact. The former Agricultural Hall in Islington was the inspiration for the Grand Hall but is a smaller and less architecturally impressive space. The Winter Gardens in Blackpool and Alexandra Palace are comparators as large-scale entertainment complexes. Olympia is also unusual for its subsequent evolution, with each additional building expanding the capacity of the site or contributing to its ability to support exhibitions and events. The individual buildings reflect their different eras of construction but contribute to the historic and architectural value of the site as a

leading exhibition venue for over 130 years. Additional buildings have maintained the pre-eminence of the Grand Hall as the primary signifier of the Olympia complex. Overall, the Olympia site is nationally rare and highly significant.

Grand Hall and Pillar Hall (listed under a single listing)

5.3.110 The Grand Hall and Pillar Hall are the earliest buildings on the site and possess the most architectural and historic interest, as reflected in their higher grade of listing. They are of national interest because of their central role in the country's cultural life and are a rare surviving example of their type. Their distinctive elevations articulate their design intention to create a national hall and provide a focal point in the local townscape. The Grand Hall provides a dramatic example of large-scale Victorian industrial engineering and technical innovation. There is great aesthetic interest in the high quality and well-preserved interiors of the Pillar Hall which was built as a set piece with the Grand Hall and provided a separate event space; the two buildings have strong group value. The boiler house chimney is also included within the list description as a subsidiary element.

National Hall and Olympia Central (listed under a single listing)

5.3.111 The National Hall and Olympia Central contribute to the historic and cultural interest of the Olympia site as a major exhibition centre. The National Hall complements the design of the Grand Hall through its restrained classical façade and its simplified, scaled-down version of the Grand Hall's barrel vaulted roof. The conference and hospitality rooms are well-preserved and attractively detailed with mahogany panelling and decorative plasterwork to the ceiling downstands.

5.3.112 Olympia Central was designed by Joseph Emberton, an important figure in the modern movement who is responsible for a number of other listed buildings including the casino at Blackpool Pleasure Beach and Simpson's, Piccadilly. It has a bold, distinctive elevation to Hammersmith Road and is a confident rendering of the Moderne style. Its interiors were intentionally plain, have been altered and very little remains of heritage interest. The National Hall and Olympia Central have strong group value with the Grand Hall and Pillar Hall.

Olympia multi-storey car park

5.3.113 The multi-storey car park was listed at Grade II in September 2018. The list description indicates that the significance of the multi-storey car park lies principally in its historical interest as an important staging post in the development of the multi-story car park in Britain, refining the tandem parking system and giving a contemporary expression to its underlying form. It is also listed for bold streamline design and its architectural interest as an important work of Joseph Emberton, architect of Olympia Central. The car park supports the exhibition use on the site and has group value with the other listed Olympia buildings.

Olympia and Avonmore Conservation Area

5.3.114 The Olympia and Avonmore Conservation Area has a mixed character, predominantly residential but with larger commercial sites along the railway line and retail uses mostly clustered along Hammersmith Road. The southern part of the conservation area is dominated by the former Whiteley's Depository site (now called Kensington Village), consisting of substantial brick-built Victorian warehousing, now primarily in office and commercial use. The central part of the conservation area is characterised by substantial Victorian terraces and late-nineteenth and early-twentieth century mansion blocks. Building heights in this sub-area of the conservation area are generally of domestic scale, with residential terraces of three to four storeys and some mansion blocks rising to five storeys. The Olympia exhibition site occupies the northern part of the conservation area and makes a significant contribution to the character of the area because of its size, scale, distinctive character, quality of architecture and exhibition use.

Significance of Adjacent Heritage Assets (LBHF)

Blythe House (Grade II listed in part)

5.3.115 Blythe House built c.1900 is significant as an impressive composition on a monumental scale by Henry Tanner, an important figure in late-Victorian and Edwardian public architecture. It has historic interest as the former headquarters of the Post Office Savings Bank, among the largest government building projects of the period, representing both the proto-socialist paternalistic state and the increasing democratisation of wealth in Imperial Britain. It has group value with the adjacent West Kensington Post Office and Delivery Office (Grade II listed), also designed by Tanner. Blythe House is a local landmark; its elevations, surmounted by the twin cupolas flanking the main entrance, make a distinctive contribution to the local streetscape, as does the tall brick campanile-style chimney to the south. The later eastern wing is excluded from the listing, but is a locally listed building of merit.

West Kensington Post Office and Delivery Office (Grade II listed)

5.3.116 West Kensington Post Office and Delivery Office built c.1900 were built to serve the former Post Office Savings Bank Headquarters (Blythe House) and designed by the same architect, Henry Tanner. It is of a more modest scale than its neighbour, of two storeys in red brick with stone dressings. It is a characterful composition on an awkward corner site and is a good example of its type. It has strong group value with the adjacent Blythe House.

Lakeside/Sinclair/Blythe Road Conservation Area

5.3.117 Lakeside/Sinclair/Blythe Road Conservation Area lies immediately to the north west of Olympia. The area was developed from the 1870s and is characterised by densely developed streets of substantial late-Victorian terraces of two and three storeys in brick and stucco, with some distinctive local shops and pubs. Some post-war development has occurred on sites cleared after bomb damage, including modern four and five storey blocks of apartments. St Simon's Church tower is a local landmark. There are several views from the conservation area towards the Olympia site; the multi-storey car park terminates the view down Sinclair Road from the north, and there is an

important view from Hofland Road towards the prominent, vaulted roof of the Grand Hall, which covers almost the full width of the skyline.

Brook Green Conservation Area

5.3.118 Brook Green Conservation Area lies immediately to the west of Olympia. The conservation area has sixteenth century origins, but the majority of its buildings date from its late-nineteenth century development. Its character is predominantly residential terraces, with some larger schools, public and ecclesiastical buildings including St Paul's Girls School. Building heights are predominantly two-to-three storeys, but there is also a wide spread distribution of taller commercial, retail, educational and mansion block buildings of four and five storeys including Blythe House in the north east corner, rising to up to eight and nine storeys of Latymer Court along Hammersmith Road. The scale and massing of the buildings on Hammersmith Road, which are considerably greater than those on the residential streets leading to Brook Green, acts as a defined edge to the conservation area. There is a view from the conservation area looking down Blythe Road towards Blythe House and the Olympia site.

Dorcas Estate Conservation Area

5.3.119 Dorcas Estate is located on the south side of Hammersmith Road, to the south west of Olympia. It is a small, compact conservation area, characterised by late-Georgian and Victorian residential terraces of two-to-three storeys, with terraces of up to four storeys with shops at street level lining Hammersmith Road. It has a regular street pattern and domestic scale. At the centre of the conservation area is the former West London Magistrates Court (Grade II listed) of two storeys and basement, which respects the domestic context of the surrounding streets. To the south, taller mansion blocks outside the conservation area can be seen rising above the terraced properties. There are views from the conservation area towards the Olympia site: from North End Road looking north towards the G-Gate site by Olympia Central, and east along Hammersmith Road towards Olympia Central with the National Hall beyond, which make an important contribution to the conservation area's character.

Fitzgeorge and Fitzjames Conservation Area

5.3.120 Fitzgeorge and Fitzjames Conservation Area is a small compact conservation area located to the south of the Olympia site and adjacent to the Dorcas Estate Conservation Area. It is characterised by well preserved, large, grand mansion flat blocks. The late-Victorian mansion blocks were designed by Delissa Joseph and range from four to six storeys, in red brick with stone dressings. Their decorative detailing and lively designs create varied and attractive elevations and skyline. The conservation area also contains 1930s mansion blocks of eight storeys designed by the same practice, Joseph Architects. The mansion blocks are well preserved and form landmarks in the conservation area. They are also visible from surrounding conservation areas, including Dorcas Estate and Olympia and Avonmore. There is a view from the conservation area towards the Olympia site looking north along North End Road towards the G-Gate Site by Olympia Central.

Significance of Adjacent Heritage Assets (Royal Borough of Kensington and Chelsea)

Holland Park Conservation Area

5.3.121 Holland Park Conservation Area lies to the east of Olympia. It is centred around the remains of Grade I listed Holland House, its parkland and the speculative terraced housing surrounding it. Buildings range from exuberant Italianate mid-Victorian stuccoed houses with mews (which are Grade II listed), some large detached villas, purpose-designed artists' studio-houses, and post-war development including several high flat blocks and inward-looking 1960s housing around Abbotsbury Road. The western part of the conservation area closest to the Olympia site is characterised by handsome mid-Victorian villas and terraces of two and three storeys in stock brick with stucco and generous front gardens.

Edwardes Square/Scarsdale Conservation Area

5.3.122 The Edwardes Square/Scarsdale Conservation Area is located to the south east of Olympia. It is characterised by handsome late Georgian and mid-Victorian residential terraces of two to three storeys, with some later Edwardian mansion blocks rising to five storeys. It is predominantly residential in character and contains several listed terraces including Earls Terrace.

Holland Park Registered Park and Garden (Grade II)

5.3.123 The former parkland and woodland surrounding the Grade II listed Holland House is now a public park and is a Registered Park and Garden (Grade II).

Listed Buildings - Impacts

Assessment of impacts on Grand Hall and Pillar Hall (Grade II*)

Changes to public realm and re-landscaping

5.3.124 The removal of the modern entrance buildings and staircases from the Olympia Way façade of the Grand Hall will have a positive impact on the listed building by better revealing the historic elevations and enabling the building's façade to be appreciated more fully. It will help to re-establish the building's historic setting and relationship with Olympia Way and improve views of the listed building from the conservation area.

5.3.125 The re-direction of traffic away from Olympia Way will also have a positive impact on the setting of the listed buildings by improving the immediate townscape and how the buildings are experienced in the streetscene.

5.3.126 The proposed re-landscaping of Olympia Way will have a positive impact by creating a more attractive public realm around the listed buildings, enhancing their setting.

Repairs and restoration of elevations

5.3.127 Proposed repairs to the facades of the Grand Hall and Pillar Hall will have a positive impact, by enhancing the appearance of the listed buildings. The restoration of lost or damaged features, including the damaged bas relief within the triumphal arch of Grand Hall and the statue of Britannia surmounting the Grand Hall will also have a positive impact by reinstating lost historic features and enhancing the appearance of the facades, better revealing the significance of the listed buildings.

Grand Hall decks

Principle

5.3.128 The proposed decks at the west end of the Grand Hall will change the spatial experience of the Grand Hall and reduce the sense of a dramatic open space which Historic England identifies as an important element of its architectural interest. The decks will change the spatial quality of the Hall, reducing views of the west gable of the barrel vaulted roof. However, it will still be possible to appreciate the full volume of the space at the east end and to see the extent of the barrel vaulted roof. The decks will allow an enhancement of the building's ability to host exhibitions, improving the usability of the relatively narrow gallery and allowing greater connectivity between the upper and lower parts of the exhibition hall. This is accepted to support the long-term viability of the building in its original use. Whilst the insertion of decks will cause some harm to the significance of the Grand Hall by dividing the primary open space this is considered to be less than substantial harm. The sympathetic design of the metal supporting structures to the decks helps to integrate them into their context.

Balustrades

5.3.129 The applicant has indicated that the original decorative cast iron balustrades around the mezzanine gallery will be removed to enable access to the lower deck. This would equate to the removal and storage of around a third of the balustrades, which would be controlled by condition. The removal of these characterful, original and highly significant balustrades would reduce the architectural and aesthetic interest of the Grand Hall, altering the character of the gallery of the Grade II* listed building; it would therefore constitute some harm to its significance.

Level 2 sky deck

Removal of existing linking structures

5.3.130 The proposed demolition of the late twentieth-century link building between Grand Hall and National Hall will have a positive impact on the listed buildings, as it will improve the articulation of the distinct relationship between the Grand Hall and National Hall and will reveal more of the side return of the Grand Hall.

5.3.131 The creation of a link from the Grand Hall through to L2 Canopy will require the removal of metal roof sheets of no historic interest to create an opening in the roof of Grand Hall. It is understood that this design seeks to maintain the connection between Olympia Grand and Olympia National and the historic

interoperability between the two. There will be no impact on the historic roof structure and therefore this element of the proposal will have a neutral impact on the listed building.

Visual impact from within the Grand Hall

5.3.132 The addition of the L2 Canopy element will result in some loss of natural light to the Grand Hall and will have a visual presence that has not historically formed part of the experience of the primary exhibition space. The visibility of this element is likely to be most apparent after dark when it is likely that the lit, glazed L2 Canopy (and proposed Central Workspace office block) will be visible from within the glazed exhibition hall, reducing the experience of the exhibition hall as the primary element of the Olympia complex and causing some less than substantial harm.

Introduction of columns

5.3.133 The construction of the L2 Canopy will require the introduction of new columns through the existing Grand Hall south mezzanine to support the L2 Canopy structure and some structural interventions into the south elevation of the Grand Hall. The columns will not align with the existing structural grid, understood to be necessary to avoid the existing historic ironwork, but this will affect the sense of symmetry and regularity which is a significant part of the architectural (and engineering) significance of the historic structure. The introduction of columns into the previously open mezzanines is likely to alter the character of these areas and cause some harm to the internal appearance of the Grand Hall.

Construction

5.3.134 The introduction of new columns will result in localised removal of modern roof glazing and openings in the mezzanine and ground floor slabs, so minor loss of historic fabric, which is judged to be of less than substantial harm.

External views

5.3.135 The new canopy of the L2 Canopy is set back from the main barrel vault to reduce competition in views of the roof of the Grand Hall, however, it may be more visually dominating in night time views when the glazed interiors are lit up. It is likely to have a minor negative impact on the setting of the Grand Hall by reducing the dominance of the barrel vaulted roof in views, judged to be of less than substantial harm.

National Hall Hotel

5.3.136 The proposed two-three storey hotel extension on top of National Hall would have some harm on the significance of the Grand Hall, since the existing barrel vaulted roofs to National and Grand Hall are distinctive signifiers of the Olympia complex and form a group, which the additional massing of the hotel extension would compete with.

Olympia West

5.3.137 It is proposed to extend Olympia West upwards by two storeys. This will be set back from the roof of the Grand Hall, but will reduce some views of the Grand Hall from the Olympia and Avonmore Conservation Area and the adjacent Brook Green and Lakeside/Sinclair/Blythe Road Conservation Areas. The extension will lead to some reduction in light at the west end of the Grand Hall and will be partially visible in views out of the Grand Hall to the west, but largely screened by the new internal decks. It will therefore cause some less than substantial harm to the setting of the listed building.

Olympia Central – Central Workspace and Logistics Centre

Visual impact from within the Grand Hall

5.3.138 The addition of the Central Workspace and Logistics Centre will result in some loss of natural light to the Grand Hall and will have a visual presence that has not historically formed part of the experience of the primary exhibition space. The visibility of this element is likely to be most apparent after dark when it is likely that the lit, glazed Central Workspace office block (and proposed L2 Canopy) will be visible from within the glazed exhibition hall, reducing the experience of the exhibition hall as the primary element of the Olympia complex and causing some less than substantial harm.

External views

5.3.139 The fifth tower of the office block will overhang the south west corner of the Grand Hall, diminishing its importance in long-range views. At present, the barrel vaulted roof of the Grand Hall is the focal point of the Olympia complex, reflecting its status as the most significant structure on the site and announcing the exhibition and events use of the site. The creation of the Central Workspace and Logistics Centre, which rises to 13 storeys, will cause harm to the setting of the Grand Hall by reducing its visual prominence in the Olympia complex and drawing attention away from the Grand Hall and its distinctive roofscape. The primary signifier of the Olympia site will no longer be the exhibition hall, but the new office block, which will be a fundamental change in the relative importance of the different parts of the complex. As the setting of the Grand Hall contributes to its significance as the most distinctive element of Olympia, the harm to the Grand Hall's setting is considered to cause harm at the higher end of less than substantial to the building's overall significance. The harm has been minimised through thoughtful incorporation of pleated glazing into the design of the office element, drawing on stylistic details of Grand Hall.

Demolition of Olympia Central and construction of basement

5.3.140 It is proposed to construct a two-storey basement beneath the Central Workspace building to create a logistics centre and parking area. A condition will require submission of details of structural protection and monitoring during the works.

Alterations to MSCP

5.3.141 The existing MSCP is one storey higher than the parapet level of the Pillar Hall and Grand Hall, but presents a low-key elevation to Olympia Way which gives precedence to the Grand Hall and Pillar Hall. The proposals include an additional two storeys on top of the existing MSCP and a new glazed stair core at the corner of Olympia Way and Maclise Road. It is considered that the visually energetic design of the building and increased height of the new stair core and upper elements will compete visually and draw attention away from the elevations and roofline of the Grand Hall and, particularly, of the polite classical façade of the adjacent Grade II* listed Pillar Hall, and is therefore considered to cause some harm to their setting.

5.3.142 The proposals include a basement extension to house a cinema. This will be constructed adjacent to the Pillar Hall. A condition will require submission of details of structural protection and monitoring during the works.

Internal refurbishment of Pillar Hall

5.3.143 The proposed internal refurbishment of the Pillar Hall and increased public access to the building would be a positive benefit, enabling more people to appreciate its fine interiors. The insertion of a lift into the existing stairwell would have a neutral impact, as the circulation space is an area of low significance within the listed building and is appropriately mitigated by fact that the proposals will improve public access to the significant interiors.

G-Gate Theatre

5.3.144 There will be limited intervisibility between the new 10-storey theatre building at G-Gate and the Grand Hall and Pillar Hall as it will be largely screened by the new Central Workspace and Logistics building. Therefore it is unlikely to have an impact on the setting of the listed buildings.

L-Yard Energy Centre

5.3.145 The proposed energy centre will rationalise the existing services across the Olympia site and concentrate them in a building within the historic service yard to the rear of the Pillar Hall and adjacent to the Grand Hall. While the scale of the energy centre is relatively large, it represents an evolution of historic services in this location at the site and will support the ongoing use of the Olympia site. Rationalising the services will help to reduce clutter across the site and increase efficient use of energy.

5.3.146 The proposed flue will be large and visually dominating, dwarfing the curtilage listed boiler house chimney and rising significantly higher than the roof of the Grand Hall. It will therefore have an impact on views of the listed buildings and cause some harm to their setting, but is accepted as a reasonable element in principle. A condition will require submission of the detailed design and materials of the flue.

Summary

5.3.147 In terms of design, the new Central Workspace building will harm the setting of the Grand Hall as the Grand Hall will no longer be the most prominent building

in the Olympia complex. As the setting of the Grand Hall contributes to its significance as the most distinctive element of Olympia, the construction of the new Central Workspace building will cause harm to the Grand Hall's setting. However, the Grand Hall will retain its historic and architectural interest, and so overall the harm is assessed to be at the higher end of less than substantial harm.

Assessment of impacts on National Hall (Grade II)

Reinstatement of Olympia Way access

5.3.148 Proposals to reinstate the Olympia Way access point to the National Hall will have a positive impact on the listed building by restoring the historic access point and removing the existing unsightly roller shutters, which will improve the appearance of the National Hall.

Re-landscaping

5.3.149 The proposed re-landscaping of Olympia Way will have a positive impact by creating a more attractive public realm around the National Hall, enhancing its setting.

National Hall - Insertion of decks

Principle

5.3.150 The insertion of decks will change the spatial experience of National Hall by infilling part of the arena and reducing the sense of open spaciousness which contributes to its special interest, but it will still be possible to appreciate the extent of the barrel vaulted roof and the hall's volume. The decks will allow an enhancement of the building's ability to host exhibitions, improving the usability of the relatively narrow mezzanine gallery and allowing greater connectivity between the upper and lower parts of the exhibition hall. This is accepted to support the long-term viability of the building in its original use. Whilst the insertion of decks will cause some harm to the significance of the National Hall by dividing the primary open space this is considered to be less than substantial harm.

Construction

5.3.151 The proposed decks will require piled foundations through the modern floor slab. A condition will require submission of details of structural protection and monitoring during the works.

L2 Canopy

5.3.152 The addition of the L2 Canopy will result in some loss of natural light to the National Hall. The construction of the L2 Canopy will require the introduction of new structural columns through the National Hall north mezzanine to support the L2 Canopy structure.

5.3.153 The introduction of new columns will result in localised removal of modern roof glazing and openings in the mezzanine and ground floor slabs, so minor loss of historic fabric. Any wider impacts upon the structure of the National Hall from inserting new columns themselves are not addressed in the submission.

5.3.154 The columns will not align with the existing structural grid, understood to be necessary to avoid the existing historic ironwork, but this will affect the sense of symmetry and regularity which is a significant part of the architectural (and engineering) significance of the historic structure. The introduction of columns into the previously open mezzanines is likely to alter the character of these areas and cause some harm to the significance of the National Hall, but this is considered to be less than substantial.

National Hall Hotel

Relationship with existing building

5.3.155 The proposed two-three storey hotel extension above the National Hall function rooms is of a distinctive design and will be set back from the elevation so that it reads as an addition. The design of the extension is boldly different to the façade of the National Hall. In long-range views, such as from Hammersmith Road, the height of the extension means that it has a dominating appearance compared with the scale of the host building, detracting from its appearance and contribution to the townscape. In closer views, it partially obscures views of the National Hall's barrel vaulted roof, which is a distinctive signifier of the Olympia complex and forms a group with the larger Grand Hall roof. The harm has been minimised through good quality detailed design and materials.

Impact of construction

5.3.156 The extension will also have a significant impact on the currently well-preserved interiors of the National Hall. Around 27 new columns will be introduced from basement to roof level to support the new structure above. In addition, a new stair core will be created to accommodate the hotel entrance. The insertion of new columns will intrude into the ornate function spaces and have an impact on their proportions, causing harm to the historic interiors of the National Hall.

5.3.157 Overall, the proposals will cause harm to the external appearance of the building by introducing a large extension which reduces the impact of the National Hall's distinctive barrel vaulted roof in the streetscene. The proposals will also cause some harm to the historic interiors. The conference rooms are ancillary to the main hall but are attractive, well-preserved spaces which contribute to the building's function and significance. The proposals will therefore cause some harm to the listed National Hall. This is considered to be at the higher end of less than substantial harm.

Central Workspace and Logistics Centre

5.3.158 The development of the Central Workspace and Logistics Centre will cause harm to the setting of the National Hall by reducing the dominance of the Grand Hall and National Hall barrel vaulted roofs in the Olympia skyline and drawing attention away from the listed buildings. The primary signifier of the Olympia

site will no longer be the distinctive roofs of the exhibition halls, but the new office block, which will be a fundamental change in the relative importance of the different parts of the complex.

5.3.159 It is proposed to construct a two-storey basement beneath the Central Workspace building to create a logistics centre and parking area. A condition will require submission of details of structural protection and monitoring during the works.

5.3.160 The construction of the Central Workspace building may cause some harm to the physical fabric of the National Hall. The new Central Workspace building will harm the setting of the National Hall by reducing the prominence of the exhibition halls in the Olympia complex. The overall impact of the new Central Workspace is less than substantial harm to the significance of the National Hall.

G-Gate Theatre

5.3.161 There will be limited intervisibility between the new 10-storey theatre building at G-Gate and the National Hall as it will be largely screened by the new Central Workspace and Logistics building and by the curve of Hammersmith Road. It is therefore considered unlikely to have a significant impact upon the setting of the National Hall.

L-Yard Energy Centre

5.3.162 The L-Yard energy centre will be separated from the National Hall by the intervening Grand Hall. The proposed chimney will rise higher than the roof of the Grand Hall and the top part may therefore be seen in the background of some views of the National Hall from Hammersmith Road and Avonmore Road. However, given the distance between the chimney and the National Hall, the chimney is unlikely to be particularly dominant in views and the impact on the setting of the National Hall is likely to be negligible.

Assessment of impacts on Olympia Central (Grade II)

Façade retention

5.3.163 The façade of the Olympia Central building is the element of highest significance, so the proposals to retain the façade will preserve the building's distinctive architectural expression and its contribution to the wider townscape.

5.3.164 The demolition of the building behind the façade will cause some harm to the listed building through loss of historic fabric, diminished ability to understand the architect's design intent for the building and loss of relationship between the façade and the building behind it. However, the interiors of Olympia Central are designedly plain, have been altered and Historic England has indicated that they are of little heritage interest, therefore the proposed demolition of the building behind the façade is considered to cause less than substantial harm to the significance of the listed building.

5.3.165 The scheme proposes the removal of paint from the building's façade and restoration of original exposed concrete finish. Details of these works will be controlled by a condition.

Construction of Central Workspace and Logistics Centre

5.3.166 The massing of the new Central Workspace has been stepped back to reduce its impact on the existing building, enabling the original façade to be read still as an architectural composition in the streetscape. The new development is strikingly different to the existing façade in terms of massing and detailed design and would reduce the sense of the listed building as a dominating presence along Hammersmith Road. The scale of the new development dominates the retained façade and changes the way the building is experienced in the streetscape. It will therefore cause less than substantial harm to the listed building.

G-Gate Theatre

5.3.167 The construction of the G-Gate theatre on the vacant plot adjacent to Olympia Central will introduce a significantly taller building which will dominate the retained façade of Olympia Central and reduce its prominence in the streetscene. It will therefore cause some harm (less than substantial) to Olympia Central's setting, however there is an extant permission for a redevelopment of the G-Gate site for a building taller than the existing Olympia Central façade.

National Hall

5.3.168 The additional two storeys and contrasting materials of the extension to the National Hall will alter its relationship with the retained façade of Olympia Central, which at present is the more dominant feature along Hammersmith Road. The impact on Olympia Central's setting is considered to be minor as its bold elevation will still make a strong contribution to the townscape.

Olympia West

5.3.169 The additional storey at Olympia West will be screened in views from Hammersmith Road by the new Central Workspace development and the G-Gate theatre, so there will be no intervisibility between the retained façade of Olympia Central and the Olympia West development. It is therefore considered that there will be no impact on Olympia Central's setting.

Assessment of impacts on Olympia multi-storey car park Grade II)

Conversion of MSCP

Use

5.3.170 The building will lose its historic use as a multi-storey car park and its new uses will largely obscure its historic function and special interest as a listed building. It is acknowledged that the car park is not used at full capacity at present and will become redundant in future. Any new use is likely to result in harm to

historic interest through loss of original use. The design of car parks makes them difficult to adapt to a new use without significant intervention into the listed building.

Demolition

- 5.3.171 The proposals will result in the loss of the majority of internal structure, including the parking floors, ramps and principal and secondary stair cores. The split level parking floors would be retained only at levels 0-3 of the western part of the building, with the ramps here rebuilt. Approximately 85% of the floorplates will be demolished. Other surviving evidence of previous use will also be largely lost.
- 5.3.172 On the exterior, the south and south-east elevations are largely demolished and replaced. The principal Maclise Road elevation is re-clad and re-glazed on levels 0-4, but demolished and reconstructed above. The curving elevation of the south east ramp is retained but over-clad. The historic central garage entrance is reconfigured. This will result in a significant loss of original fabric, diminishing the building's historic and architectural interest and the ability to appreciate the original internal design of the building, which is identified as an important part of its significance.

New build and extension

- 5.3.173 The new internal structures and layouts will obscure the building's historic function and interest. It will also break the link between the building's structural form and function, and its external architectural expression, which is an important element of its significance.
- 5.3.174 The new build elements, replacing the south-eastern part of the current building (including the principal stair core) and adding two stories to the roof, are a striking modern design. They will also have a negative impact on the setting of Pillar Hall by introducing an element which will compete visually with the Grade II* listed building.
- 5.3.175 The proposed development will substantively diminish most elements of the building's significance, altering its use, its internal layout, its façades and its massing. The overall impact on the architectural and historic importance of the multi-storey car park will therefore be substantial harm, both from the extent of the demolition of fabric which contributes to its architectural and historic interest, and from the proposed alterations and extensions.

L-Yard Energy Centre

- 5.3.176 The L-Yard energy centre will be located in the yard behind the MSCP. The proposed chimney will rise above the additional storeys of the MSCP and the top part will be visible in long views, such as along Sinclair Road (view 14). It will have a minor impact on the setting of the listed building but is accepted as a reasonable element in principle.

Re-landscaping

5.3.177 The proposed re-landscaping of Olympia Way will have a positive impact on the MSCP by creating a more attractive public realm around the listed building and improving its setting.

Olympia and Avonmore Conservation Area – Assessment of impacts

Exhibition and events use

5.3.178 The Olympia site dominates the northern end of the Olympia and Avonmore Conservation Area and the distinctive listed buildings on the site make a significant contribution to the character to the area. Proposals to maintain and enhance the site as an exhibitions and events space are positive because this contributes to the special interest of the conservation area.

Public realm

5.3.179 The removal of later additions around the Grand Hall and National Hall will better reveal the listed buildings, improve views towards them from the conservation area and will have a positive impact on the character and appearance of the conservation area by reducing visual clutter and improving the public realm. The relocation of traffic and logistics away from Olympia Way will improve the setting of the listed buildings and the townscape of the conservation area.

Central Workspace and Logistics Centre

5.3.180 The construction of the Central Workspace and Logistics Centre will introduce a 13-storey building that is of substantially greater height and scale than most of the rest of the conservation area, which is characterised by a predominantly Victorian townscape of residential scale of around four storeys. The set-back of the massing will concentrate the height of the building in the centre of the Olympia site. This reduces its immediate impact on the townscape of Hammersmith Road and on the retained Olympia Central façade, which will largely maintain its presence on Hammersmith Road, but increases its harmful effect on the setting of listed Grand Hall.

5.3.181 The height of the building means that it will have a considerable impact on the wider conservation area, including the residential terraces and mansion blocks to the south of the Olympia site, as it will appear above the roof profile of existing buildings (e.g. View 5, from Avonmore Road). Its glazed elevations have been designed to reference the pleated glazing of the Grand Hall roof. The extent of glazing means that its night time impact, particularly during the winter months, will be amplified as floors of illuminated windows will dominate the skyline and divert attention from the listed buildings, in particular the Grand Hall and National Hall roofs.

5.3.182 The new building is out of scale with the surrounding conservation area and will dominate the existing townscape because of its height and massing. The development will therefore cause harm to the existing character and appearance of the conservation area.

G-gate Theatre

5.3.183 The vacant plot site by Olympia Central detracts from the conservation area by interrupting the prevailing building line along Hammersmith Road and removing the sense of enclosure which would have been provided by buildings fronting the road. In principle, introducing a new building on the site would have a positive impact on the conservation area.

5.3.184 The proposed ten-storey G-Gate theatre will introduce a building of significantly greater scale than the predominant building height along Hammersmith Road. View 4 (the view north along North End Road) indicates how the new building will dominate the modest scale of the existing, predominantly two to four storey buildings along the east side of North End Road, and introduce a dominating building which is out of keeping with the prevailing building heights and massing of the conservation area.

5.3.185 It should be noted that there is extant planning permission for a 7-9-10 storey hotel development on this site and the inspector at the call-in inquiry accepted the principle for a landmark building on this site which was taller than its immediate surroundings. Nevertheless, there are concerns about the architectural expression of the proposed G-Gate theatre as design constraints have led to the stage end of the theatre being positioned at the Hammersmith Road side of the building, reducing the potential to introduce windows into this elevation. This means that the building presents a large, unrelieved façade with a predominantly blank elevation to Hammersmith Road, and will not deliver a fully animated façade to the public realm.

5.3.186 It is therefore considered that the height and architectural character of the proposed G-Gate theatre will cause some harm to the character and appearance of the conservation area.

L2 Canopy

5.3.187 The L2 Canopy references the glazed roofs of the Grand Hall and National Hall but is set back and intended to be subordinate to the existing roofs. It uses materials and forms which are similar to the existing roof structures at Olympia and will therefore preserve the character of the conservation area.

National Hotel

5.3.188 The additional storeys for the National Hotel are in keeping with the prevailing building heights in this part of the conservation area. The development introduces curved zinc panels as cladding. There is already a variety of materials and architectural treatment on the Olympia site and the impact of the new development on the wider conservation area is considered to be neutral.

L-Yard Energy Centre

5.3.189 The proposed new chimney of the energy centre will rise higher than the existing boiler chimney and will therefore be more visible in wider views. It is set back behind the existing brick chimney, reducing its dominance, and its impact on the wider conservation area is considered to be neutral.

Multi-Storey Car Park

5.3.190 The works to the MSCP will increase the height of the building to seven storeys, which is slightly higher than the surrounding terraces but is overall in keeping with the building heights across the Olympia complex and the impact of the new development on the wider conservation area is considered to be neutral.

Olympia West

5.3.191 The height and scale of development at Olympia West is in keeping with the prevailing building heights of the conservation area and maintains the existing building line. It introduces bronze coloured rainscreen cladding in a diagonal pattern, but this is in keeping with the variety of materials and architectural treatment already existing on the Olympia site and will preserve the character of the conservation area.

Setting of Adjacent Heritage Assets – Assessment of impacts

Blythe House and West Kensington Post Office and Delivery Office (Grade II listed)

Central Workspace and Logistics Centre

5.3.192 The construction of the Central Workspace and Logistics Centre will have an impact upon the setting of Blythe House by introducing a new taller building in the background to views of Blythe House. This is particularly evident in the view from Blythe Road looking east (view 13), where at present the distinctive cupolas of Blythe House terminate the view. The new Central Workspace building will rise up behind Blythe House, altering the skyline and reducing the impact of Blythe House's characteristic silhouette against the sky.

5.3.193 This will therefore cause some harm to the setting of Blythe House by reducing its pre-eminence in views from Blythe Road.

Olympia West

5.3.194 The alterations to Olympia West opposite the West Kensington Post Office and Delivery Office include raising the building height by two storeys and changing the elevational treatment. The existing building line will be preserved. At present, the West Kensington Post Office is a smaller-scale building surrounded by larger-scale buildings, so the development will not affect its comparative relationship to its surroundings. Its close relationship with Blythe House will be preserved and will still be able to be appreciated. The impact upon the setting of the Post Office and Delivery Office is considered to be overall neutral.

Lakeside/Sinclair/Blythe Road Conservation Area

5.3.195 There are several views of the Olympia site to the south from this adjacent conservation area, including views down Hofland Road and Sinclair Road. The development of the MSCP will have an impact on the view down Sinclair Road (view 14), as the additional stories will mask the Grand Hall roof behind and

introduce a building of increased scale terminating the view down the road. The impact is harmful in masking views of the Grade II* listed building. The new chimney at L-Yard will also be visible in long views from Sinclair Road because of its height; this will have a minor negative impact because of the prominence of the structure against the skyline.

5.3.196 The view towards Blythe House from Blythe Road (view 13) will also be affected as the new building will alter the skyline, rising up behind the distinctive cupolas of Blythe House and reducing its pre-eminence in views from the conservation area, causing some harm.

5.3.197 The Central Workspace development will appear above the roofline of the residential terraces in several locations. The impact causes some harm to the setting of the conservation area by introducing a large, dominant building in contrasting scale to the conservation area which is visible in views from within the conservation area. The overall impact on the conservation area is considered to be less than substantial harm.

Brook Green Conservation Area

5.3.198 The effect of the new development at Olympia on views within and without the Brook Green Conservation Area will be mostly negligible. The additional storeys on Olympia West will reduce some views of the barrel vaulted Grand Hall roof from the Brook Green Conservation Area but as there are limited views of this elevation the impact is very minor.

5.3.199 The main impact will be on views of Blythe House from within the conservation area, as the new Central Workspace and Logistics Centre will rise up behind it in some views, reducing the impact of the silhouette of the roofscape of Blythe House within the conservation area. This will have a minor harmful effect upon the Brook Green Conservation Area.

Dorcas Estate Conservation Area

5.3.200 The conservation area is characterised by the domestic scale of the Georgian and Victorian residential terraces, which is maintained by the former Magistrates' Court at the centre of the conservation area. The G-Gate theatre and Central Workspace development will be visible from within the Conservation Area, rising above the existing rooflines of the residential terraces.

5.3.201 The impact of the development causes some harm to the setting of the conservation area by introducing a large, dominant building which is visible from within the conservation area.

Fitzgeorge and Fitzjames Conservation Area

5.3.202 The main impact of the development on the Fitzgeorge and Fitzjames Conservation Area will be the alteration in the view north along North End Road towards the new G-Gate theatre. The mansion blocks are prominent buildings along North End Road. The G-Gate theatre will compete in views down the road by introducing a taller building which stands out amongst the domestic

scale of the surrounding townscape. This will have a minor harmful effect to the character of the Fitzgeorge and Fitzjames Conservation Area by reducing the prominence of the mansion blocks in the townscape. However, there is extant planning permission for a hotel development on the G-Gate site which would rise up to nine and ten storeys, so the impact of the proposed development needs to be considered in conjunction with that of the existing permission for this site.

RBKC: Holland Park Conservation Area

5.3.203 The exhibition halls at Olympia form the backdrop to the local streetscene in several views from the Holland Park Conservation Area, especially in roads running east-west such as Melbury Road, Napier Road, Holland Park Road and Kensington High Street. The development of the Central Workspace and Logistics Centre will have an impact on these views by introducing a tall building which is visible above the roofline of the residential terraces and which contrasts with the predominantly Victorian townscape. In view 8 (west down Napier Road towards Olympia's Grand Hall) the Central Workspace will dominate the adjacent Grand Hall and divert attention from the Grade II* building. The conservation area appraisal identifies this as an important townscape view. The impact of the new development is harmful as it distracts attention from the Grade II* listed Grand Hall and harms the setting of the conservation area, but the impact on the conservation area as a whole is less than substantial harm.

5.3.204 The Heritage, Townscape and Visual Effect Assessment indicates that the upper storeys of the Central Workspace development will be seen from much of Holland Park (a Grade II listed Registered Park & Garden). At present, the existing building line is largely screened by trees, creating a tranquil green setting. The new building will appear above the tree line but in Officer's opinion will not cause harm to the setting of the Registered Park & Garden, which is an important contributor to the character of the conservation area, although the impact on the character of the conservation area as a whole is considered to constitute less than substantial harm.

RBKC Edwardes Square/Scarsdale Conservation Area

5.3.205 Although verified views from Edwardes Square have not been assessed in the submission, it is likely that the Central Workspace will be visible from Edwardes Square, rising above the roofline of the listed terraces lining Edwardes Square and Alma Place.

5.3.206 This will introduce a large, dominant building which is visible from within the conservation area and is of a contrasting scale to the character and appearance of the conservation area. It will therefore cause some harm to the setting of the conservation area.

Summary: Heritage Impacts

Grand Hall

5.3.207 The proposed scheme would deliver several positive impacts for the Grand Hall. The removal of the modern entrance buildings in front of Grand Hall and restoration of the façade and lost or damaged historic features will enhance the significance of the listed building. The public realm improvements to Olympia Way will enhance its setting.

5.3.208 The scheme will also cause harm to the listed building. The insertion of decks into the Grand Hall will reduce the sense of dramatic open space which is an important element of its architectural interest. The removal of a third of the decorative cast iron balustrades to provide access to the decks would reduce the architectural and aesthetic interest of the Grand Hall and cause harm to its significance. The insertion of columns to support the Level 2 skydeck will intrude into the open mezzanines and affect the internal character of the Grand Hall.

5.3.209 The Central Workspace development will cause harm to the setting of the Grand Hall by reducing its visual prominence in the Olympia complex and drawing attention away from the Grand Hall and its distinctive roofscape. The primary signifier of the Olympia site will no longer be the exhibition hall, but the new office block, which will be a fundamental change in the relative importance of the different parts of the complex.

5.3.210 The raised height of Olympia West, the canopy of the Level 2 skydeck, and the development along Olympia Way, will also cause some harm to the setting of the listed building.

5.3.211 Overall, it is considered that although the development will cause harm to the significance of the Grand Hall, this is at the higher end of less than substantial harm, because its historic and communal interest, and much of its architectural interest, will still be maintained and able to be appreciated.

Pillar Hall

5.3.212 The proposed internal refurbishment of the Pillar Hall and increased public access to the building would have a positive impact on the listed building by bringing it back into active use and enabling more people to appreciate its fine interiors. The additional storeys and new stair core for the MSCP will cause some harm to the setting of the Pillar Hall by their increased dominance, drawing attention from the Pillar Hall elevation. Overall, the scheme will cause some harm (less than substantial) to the significance of Pillar Hall.

National Hall

5.3.213 The reinstatement of the Olympia Way access point will have a minor positive impact on the National Hall restoring the historic access point to the building.

5.3.214 The insertion of decks into the National Hall will cause harm by reducing the sense of spaciousness which contributes to its special interest. The insertion of columns to support the Level 2 skydeck will intrude into the open mezzanines and alter the character of these areas.

5.3.215 The additional storeys for the National Hall Hotel will cause harm to the well-preserved interiors of the conference rooms through the addition of new columns in these spaces. The extension will cause harm to the external elevations of the National Hall by introducing an extension of a scale which will reduce the impact of the its distinctive barrel vaulted roof in the streetscene.

5.3.216 The Central Workspace development will cause harm to the setting of the National Hall by reducing the dominance of the Grand Hall and National Hall barrel vaulted roofs in the Olympia skyline and drawing attention away from the listed buildings. The primary signifier of the Olympia site will no longer be the paired exhibition halls of Grand Hall and National Hall, but the new office block, which will be a fundamental change in the relative importance of the different parts of the complex.

5.3.217 The proposals will therefore cause harm to the listed National Hall. Overall, the level of harm caused to the significance of National Hall is considered to be at the higher end of less than substantial harm, because its historic and communal interest will mostly be maintained, although its architectural interest will be harmed by the scheme.

Olympia Central

5.3.218 The façade of the Olympia Central building is the element of highest significance, so the proposals to retain the façade will substantively preserve the building's distinctive architectural expression and its contribution to the wider townscape, but the demolition of the building behind the façade will cause some harm because the elevation will lose its context and it will no longer be possible to understand the architect's design intent for the building.

5.3.219 The new Central Workspace development will cause harm to Olympia Central because the scale of the new development dominates the retained façade. The new G-Gate theatre adjacent will cause harm to Olympia Central's setting by introducing a significantly taller building which will dominate the retained façade of Olympia Central and reduce its prominence in the streetscene, although there is an extant planning permission for the redevelopment of the G-Gate site with a building of greater scale than the Olympia Central facade.

5.3.220 Overall, the scheme is considered to cause less than substantial harm to Olympia Central because it preserves the element of highest significance, its distinctive façade, although it will lose its context and its presence in the streetscene will be diminished by the new development.

Multi-storey Car Park

5.3.221 The proposed scheme will result in the loss of the historic use of the MSCP and substantial demolition both internally and externally. Around 85% of the MSCP floorplates will be demolished, including evidence of the historic layout such as the split level parking floors in the eastern part of the building. The building will be re-clad and re-glazed. This will result in a significant loss of original fabric, diminishing the building's historic and architectural interest and the ability to appreciate the original internal design of the building, which is identified as an important part of its significance.

- 5.3.222 The new staircore and additional storeys are a striking modern design. The new internal structures and layouts will obscure the building's historic function and interest. It will also break the link between the building's structural form and function, and its external architectural expression, which is an important element of its significance.
- 5.3.223 The proposed development will substantively diminish most elements of the building's significance, altering its use, its internal layout, its façades and its massing. The overall impact on the architectural and historic importance of the multi-storey car park will therefore be substantial harm, both from the extent of the demolition of fabric which contributes to its architectural and historic interest, and from the extent of the proposed alterations and additions.

Olympia and Avonmore Conservation Area

- 5.3.224 The proposals to maintain and enhance the site as an exhibitions and events space will have a positive impact on the conservation area because these buildings and uses contribute to the special interest of the conservation area. The improvements to the public realm around the Grand Hall and the National Hall will have a positive impact on the character and appearance of the conservation area.
- 5.3.225 The new G-Gate building introduces a dominating building which is out of keeping with the prevailing building heights of the conservation area and presents a large, unrelieved façade with a predominantly blank elevation to Hammersmith Road. It is therefore considered that the height and architectural character of the proposed G-Gate theatre will cause some harm to the character and appearance of the conservation area.
- 5.3.226 Central Workspace building new building is of substantially greater height and scale than the rest of the conservation area and will dominate the existing townscape because of its height and massing. The development will therefore cause harm to the existing character and appearance of the conservation area.
- 5.3.227 Overall, therefore, the development will therefore cause less than substantial harm to the character and appearance of the conservation area and will therefore not preserve or enhance the character or appearance of the conservation area.

Adjacent heritage assets

- 5.3.228 The scheme will cause less than substantial harm to the cohesive Victorian character of the adjacent Lakeside/Sinclair/Blythe Road Conservation Area and Dorcas Estate Conservation Areas by introducing a large, dominant building in contrasting scale and materiality to the conservation area which is visible in views from within the conservation area. It will have a minor harmful effect on the character of the Fitzgeorge and Fitzjames Conservation Area by reducing the prominence of the mansion blocks in the townscape.
- 5.3.229 The scheme will therefore cause less than substantial harm to the Grade II listed Blythe House by causing harm to its setting and reducing its pre-

eminence in views from Blythe Road. This will also cause minor harm to the conservation area in which Blythe House is located, the Brook Green Conservation Area.

5.3.230 In Officer's opinion the scheme will cause less than substantial harm to nearby conservation areas in the Royal Borough of Kensington and Chelsea (Holland Park Conservation Area and Edwardes Square/Scarsdale Conservation Area), by harming the setting of the conservation areas by introducing a large, dominant building which is visible from within the conservation area and is of a contrasting scale to the character and appearance of the conservation area.

Heritage Impacts Conclusion

5.3.231 It is key to the assessment of these applications that the decision making process is based on the understanding of specific duties in relation to listed buildings and Conservation Areas required by the relevant legislation, particularly the s.16, s.66 and s.72 duties of the Planning (Listed Buildings and Conservation Areas) Act 1990 and the requirements set out in the NPPF. Officers have given due weight to the statutory duties of the desirability of preserving the special architectural and historic interest of the listed buildings affected and their settings and of preserving or enhancing the character and appearance of the Olympia & Avonmore Conservation Area.

5.3.232 The NPPF states that great weight should be given to the asset's conservation, irrespective of whether any potential harm amounts to substantial harm, total loss or less than substantial harm to its significance (para 193). Where a proposal will lead to substantial harm, local authorities should refuse consent unless it can be demonstrated that the harm is necessary to achieve substantial public benefits that outweigh the harm (para 195). Where a development proposal will lead to less than substantial harm to the significance of a designated heritage asset, this harm should be weighed against the public benefits of the proposal, including, where appropriate, securing its optimum viable use (para 196).

5.3.233 The proposed development is intended to maintain the Olympia site in its historic use as an exhibition centre in the longer term, which would sustain its significance. The historical and communal significance of the site will be sustained. The scheme will deliver several benefits including making the site more permeable to casual public access, allowing more people to visit and appreciate the listed buildings.

5.3.234 However the development will have wide-ranging and cumulative impacts on all listed elements of the Olympia complex and on the wider townscape of Hammersmith and Fulham and Kensington and Chelsea. It will cause less than substantial harm to the significance of the Grand Hall, Pillar Hall, National Hall and Olympia Central. For the harm caused to these designated heritage assets the test outlined in para 196 of the NPPF would apply.

5.3.235 Considering what is the Optimum Viable Use ('OVU') of Olympia Exhibition Centre requires a two stage approach. First, any potential uses are assessed to determine whether or not they are viable; in particular consideration is given as to whether those uses can be rendered 'viable' in the sense of providing a workable, long term future for the assets. In this regard the PPG states:

‘Putting heritage assets to a viable use is likely to lead to the investment in their maintenance necessary for their long-term conservation. It is important that any use is viable, not just for the owner, but also for the future conservation of the asset. It is obviously desirable to avoid successive harmful changes carried out in the interest of repeated speculative and failed uses.’

5.3.236 Secondly, it is necessary to identify the Optimum Use of Olympia Exhibition Centre. The Optimum Use is the use that will cause least harm to the heritage asset. Again, the focus is on the long-term; in this regard, the PPG states:

‘If there is only one viable use, that use is the optimum viable use. If there is a range of alternative uses, the optimum use is the only one likely to cause the least harm to the significance of the asset, not just through necessary initial changes, but also as a result of subsequent wear and tear and likely future changes.’

5.3.237 If the Optimum Use can be rendered viable, then that use is the OVU. If that use cannot be rendered viable, then consideration passes to such other of the various uses under consideration, as would cause the ‘next least’ degree of harm to the heritage asset. If that use can be rendered viable, then that use is determined as the OVU. The PPG states:

‘The optimum viable use may not necessarily be the most profitable one. It might be the original use, but that may no longer be economically viable or even the most compatible with the long-term conservation of the asset. However, if from a conservation point of view there is no real difference between viable uses, then the choice of use is a decision for the owner.’

5.3.238 The purpose of the Planning Practice Guidance is to provide further guidance on the application of the NPPF which includes a requirement for the planning process to conserve heritage assets in a manner appropriate to their significance, so that they can be enjoyed for their contribution to the quality of life of this and future generations.

5.3.239 The proposals provide a comprehensive, masterplanned approach to restoring and redeveloping the Olympia complex by retaining and enhancing the core exhibition centre use and introducing new complementary uses. The masterplan has also been designed to enable the existing exhibition business to continue operating throughout the development process.

5.3.240 The masterplan seeks to create a destination at Olympia that would attract a larger number of visitors, to a wider range of events and facilities across a longer period of the day. The proposals would enhance the role of Olympia as the only major exhibition centre in Central London, creating a new cultural and commercial offer to support the core exhibition business, including a theatre, cinema, live music venue, hotels, offices and retail space.

5.3.241 The proposals incorporate significant improvements to existing facilities at Olympia, including a better food and beverage offer, the provision of onsite hotels and office space, as well as improved public realm and servicing arrangements which have been identified by the applicant as being necessary to better meet the needs of the exhibition industry and in order to compete with

other modern exhibition centres around the world. The proposals have been developed in conjunction with the exhibition centre business and in response to exhibitor feedback about the shortcomings of the existing exhibition centre including in relation to the limited amount of usable floor space for exhibitions in Grand Hall and National Hall, the poor quality of the exhibition floorspace at Olympia Central, the poor quality of the food and beverage offer and the lack of onsite hotels and workspace facilities.

- 5.3.242 Officers consider that the optimum use of Grand Hall and National Hall in heritage terms would be the continuation of their original use as exhibition halls, particularly due to their purpose-built design and the character and proportions of the spaces. The proposals would retain Grand Hall as an exhibition hall with additional exhibition floorspace at gallery level and food and beverage facilities on the top mezzanine level. Any alternative use of Grand Hall is likely to result in significant harm. The proposals would retain the exhibition hall at National Hall with additional exhibition floorspace at gallery level and on the top mezzanine level. Any alternative use of the exhibition hall at National Hall is likely to result in significant harm. The existing ground floor restaurant and ancillary first floor level hospitality spaces at National Hall would be converted to hotel use. Although these spaces would no longer form part of the exhibition centre use, their use within the proposed hotel for reception and hospitality would be compatible with their original use and there would be considerable synergy between hotel use and the exhibition business. The hotel extension on top of National Hall required to facilitate the change of use would cause harm to the significance of the interior of the south wing of the National Hall through the introduction of structural support columns but the scheme would facilitate the retention of the volume and proportions of the ground floor restaurant and first floor Apex Room and Club Room.
- 5.3.243 Officers consider that the optimum use of Pillar Hall in heritage terms would be the continuation of its original use as a hospitality and entertainment facility, particularly due to the plan form and character and proportions of the internal spaces. The proposal to refurbish Pillar Hall to create a restaurant with entertainment facilities would represent the optimum use of the designated heritage asset.
- 5.3.244 Officers consider that the optimum use of Olympia Central in heritage terms could be as its original use as an exhibition hall, but given the much lower level of significance of the exhibition floorspace behind the façade, a façade retention scheme in connection with the erection of replacement exhibition floorspace and complimentary conference facilities, such as is proposed, could also represent its optimum use. Any alternative use of the existing exhibition floorspace at Olympia Central, apart from storage, is likely to require harmful alteration to the façade, which is the most significant element of the building, in order to insert new window openings.
- 5.3.245 The optimum use of the Multi-Storey Car Park (MSCP) in heritage terms would be as a car park, however, officers consider this existing use as unsustainable in environmental terms since Olympia is in a Central London location with good public transport accessibility and is located adjacent to densely populated residential areas. The applicant advises that the current utilisation of the existing on-site exhibitor car parking spaces is round 50% and they are

proposing to reduce the on-site provision from 380 to 181 spaces and relocate into the Logistics Centre beneath Olympia Central. The MSCP was specifically designed to be used as a car park and was built to the standards of the 1930s. As such, finding a viable reuse of the building is likely to be challenging due to the plan form, split level car parking decks and poor thermal efficiency. It is likely that the alterations necessary to facilitate any viable reuse of the building would result in substantial harm to the significance of the listed building. Importantly, the proposed new uses for the MCSP in the form of a cinema, hotel and office uses would help to create a vibrant destination with a variety of uses that would have a natural synergy with the core exhibition centre business.

5.3.246 The Olympia site is significant as an evolving complex of exhibition buildings which relate closely to each other functionally. The group value of the site will be harmed through the demolition of Olympia Central behind the retained façade, the change in use of the National Hall south wing and the MSCP and the construction of the new office building, which changes the relative importance of the different parts of the complex. The visual prominence of the Grade II* listed Grand Hall will be diminished by the new development and the primary signifier of the Olympia site will no longer be the exhibition hall, but the new office block, which will be a fundamental change in the relative importance of the different parts of the complex. Officers have given great weight to the conservation of the Grand Hall, Pillar Hall, National Hall and Olympia Central and consider that the less than substantial harm to the significance of these designated heritage assets would be outweighed by public benefits as set out later in the Officer Report.

5.3.247 The development will cause less than substantial harm to the Olympia and Avonmore Conservation Area, the Lakeside/Sinclair/Blythe Road Conservation Area, and Dorcas Estate Conservation Area. It will cause minor harm to Blythe House, the Brook Green Conservation Area and the Fitzgeorge and Fitzjames Conservation Area. It will also cause less than substantial harm to the significance of the Holland Park Conservation Area and Edwardes Square/Scarsdale Conservation Area in the Royal Borough of Kensington and Chelsea. For the harm caused to these designated heritage assets the test outlined in para 196 of the NPPF would apply. Officers have given great weight to the conservation of these designated heritage assets and consider that the less than substantial harm to their significance would be outweighed by public benefits as set out later in the Officer Report.

5.3.248 The development will cause substantial harm to the significance of the Multi-Storey Car Park, because of the extent of the demolition of fabric which contributes to its architectural and historic interest, and the dominant nature of the proposed additions. For the harm caused to this designated heritage asset the test set out in para 195 of the NPPF would apply. Officers consider that the substantial harm caused to the Multi-Storey Car Park is necessary to achieve substantial public benefits that outweigh the harm as set out later in the Officer Report.

Conclusion

5.3.249 It is considered that the proposed development provides an opportunity for significant enhancement and regeneration of the Olympia estate. The proposals

are the result of comprehensive, masterplan approach to restoring and redeveloping the Olympia complex by retaining and enhancing the core exhibition centre use and introducing new complementary uses. The proposed development is intended to maintain the Olympia site in its historic use as an exhibition centre in the longer term, which would sustain its significance.

- 5.3.250 The proposed design would represent a further evolution of development at Olympia and would add to the high quality and rich variety of distinctive architectural styles and materials on the site. The design is informed by an understanding of the significance of the heritage assets affected and the detailed design of the individual elements is considered compatible with the adjacent listed buildings.
- 5.3.251 The proposals would also deliver well designed public realm around and through the site, improving permeability and would increase the extent of active frontages around the perimeter of the site, improving the visual relationship with the streetscene.
- 5.3.252 However, the development will have wide-ranging and cumulative impacts on all listed elements of the Olympia complex and on the wider townscape of Hammersmith and Fulham and Kensington and Chelsea. In their considered assessment, officers conclude that there will be no significant adverse effect where the proposed development is considered to cause substantial harm to any of the surrounding heritage assets. The magnitude of any harm identified has been assessed as less than substantial harm, and is considered to be outweighed by the public benefits the scheme would deliver as out lined in Section 7.
- 5.3.253 It is considered that this is compliant with Section 16, 66 and 72 of the Planning (Listed Buildings and Conservation Areas) Act 1990. It is considered that the proposals will deliver good quality architecture which optimises the capacity of the site with good exhibition, hotel, theatre, retail, leisure and commercial accommodation. The proposed development is therefore considered acceptable in accordance with the NPPF, policies 7.1, 7.2, 7.3, 7.4, 7.5, 7.6 and 7.21 of the London Plan and Policies DC1, DC2, DC4, DC7 and DC8 of the Local Plan (2018).

5.4 Daylight and Sunlight

- 5.4.1. **The NPPF (Paragraph 123 part c) and footnote 37** states that daylight and sunlight guidance should be applied flexibly ‘where they would otherwise inhibit making efficient use of a site’, so long as they continue to provide adequate living standards.’
- 5.4.2. **London Plan Policy 7.6** requires new buildings and structures to ensure that they do not cause unacceptable harm to the amenity of surrounding land and buildings in relation to a number of factors, including overshadowing. Policy 7.7 further states that tall buildings should not adversely affect their surroundings in terms of overshadowing and reflected glare.
- 5.4.3. **The Mayor’s Housing SPG Policy 7.6** makes clear that ‘an appropriate degree of flexibility’ should be applied when assessing the impacts of new development

on surrounding properties and within developments. In particular paragraph 1.3.45 states 'Guidelines should be applied sensitively to higher density development, especially in opportunity areas, town centres, large sites and accessible locations, where BRE advice suggests considering the use of alternative targets. This should take into account local circumstances; the need to optimise housing capacity; and scope for the character and form of an area to change over time.' Paragraph 1.3.46 further states 'The degree of harm on adjacent properties and the daylight targets within a proposed scheme should be assessed drawing on broadly comparable residential typologies within the area and of a similar nature across London. Decision makers should recognise that fully optimising housing potential on large sites may necessitate standards which depart from those presently experienced but which still achieve satisfactory levels of residential amenity and avoid unacceptable harm.'

- 5.4.4. **Local Plan Policy HO11** addresses detailed residential standards and, in seeking a high standard of design, seeks to ensure the protection of existing residential amenities; 'including issues such as loss of daylight, sunlight, privacy and outlook'. **Local Plan Policies DC2 and Policy DC3** state that all new builds and tall buildings must be designed to respect good neighbourliness and the principles of residential amenity.
- 5.4.5. **SPD Key Principle HS1** states that, "Where communal open space is provided, development proposals should demonstrate that the space: is designed to take advantage of direct sunlight..." And, SPD Key Principle SDC1 states that, "Other effects buildings can have on the local climate include: Overshadowing and reducing access to sunlight"
- 5.4.6. **The BRE Guidelines** are typically used to assess daylight and sunlight. The Guideline sets out three methods for assessing daylight into a room including the Vertical Sky Component (VSC) method; plotting of the no-sky line method and the Average Daylight Factor (ADF) method. The introduction to the guide however stresses that it should not be used as an instrument of planning policy and should be interpreted flexibly because lighting is only one design factor for any scheme. Sunlight assessment is based on annual probable sunlight hours (APSH) and winter sunlight hours. In terms of overshadowing of gardens and open spaces the BRE guide recommends that for an open space to appear adequately sunlit through the year, more than half of the space should receive at least two hours of sunlight at the March equinox.

Assessment

- 5.4.7. An assessment of the daylight, sunlight, and overshadowing effects of the Proposed Development on surrounding buildings and amenity space is contained within Chapter 11 of the ES. Potential solar glare impacts (i.e. reflection from surfaces) for sensitive road junctions and rail lines and a light spillage (i.e. light from the site into the surrounding area) for sensitive neighbouring residential properties have also been considered. The daylight assessment has been evaluated against the Vertical Sky Component (VSC) and No Sky Line (NSL) methods. It should be noted that the Average Daylight Factor (ADF) has not been calculated in the ES for the purposes of assessing daylight levels within neighbouring properties. This is primarily due to the fact the internal rooms, dimensions, and surfaces are usually unknown, meaning assumed

layouts and reflectance values would need to be used which can significantly influence the ADF results. In line with the BRE guidelines, the daylight assessment relies on both VSC and NSL. Further daylight/sunlight details are provided in a supplementary report. This document in particular has focussed on the impacts of surrounding buildings experiencing major adverse alterations of light. The report sets out material factors that are considered relevant when assessing the overall significance of the daylight/sunlight losses. Includes a more detailed Radiance based daylight assessment which focuses on two rooms located within 1-35 Argyll Mansions which have windows with a major adverse change in VSC. In this case floor plans for the two rooms has been assessed. The analysis indicates that although alterations in the levels of daylight amenity to the two rooms would be noticeable, it also demonstrates that the areas nearest the windows retain acceptable levels of daylight amenity. The supplementary report also comprises a comparison between the proposed development and other recent developments, the use of alternative target values based on the site's urban location, the influences of the architectural form of neighbouring properties and a review of the overall benefits of the proposal on the locality and wider area.

Daylight Assessment

- 5.4.8. The proposed development has been assessed against two different scenarios. The baseline conditions taken as the existing conditions across the site and surrounding areas have been assessed against Assessment 1: Existing Baseline against the proposed development (Masterplan Site) and Assessment 2: Existing Baseline against the Olympia Estate (Masterplan Site coming forward in conjunction with the Olympia Way Site). The effect of 66 Hammersmith Road located to the south-west corner of the Olympia Estate which has received a resolution to grant permission since the application has been submitted and proposed development at 10 Beaconsfield Terrace Road (the Printworks) have also been taken into consideration.
- 5.4.9. Concerning the possible effects on surrounding receptors external to the site, a total of 2,935 windows serving 1,499 rooms were assessed within 122 surrounding residential properties. In addition to the residential receptors, St James Junior and Senior Girls School in Earsby Street has been included in the assessment. The residual effects listed in the assessment range between 'negligible' (effects considered to be 'not significant' and not a matter of local or wider concern), 'moderate to major adverse' (effects deemed to be 'significant') or 'major adverse' when compared to BRE guidelines.
- 5.4.10. In terms of Assessment 1 against the Masterplan Site, for the VSC test, 2,545 (87%) of the 2,935 windows assessed would either meet the BRE criteria and experience a negligible effect, or experience a minor adverse effect which is not considered significant. 135 windows (4%) would experience a moderate adverse effect (significant) and 255 windows (9%) would experience a major adverse effect (significant). On close examination of the major adverse effects, the applicant identifies 228 (89%) of the 255 windows are in four properties (72 Blythe Road, 1-50 Palace Mansions, 1-35 Argyll Mansions and 67-81 Hammersmith Road).

- 5.4.11. Of the 255 windows experiencing a major adverse effect, 110 windows are classified as less sensitive bedrooms non-habitable dressing rooms; 28 windows are located beneath deep overhanging balconies in 72 Blythe Road which restrict access to sky visibility and make the windows highly sensitive to alterations in massing; and 21 windows achieve low existing VSC below 15%, whereby small absolute alterations can result in large disproportionate percentage alterations. This leaves 96 windows which experience major adverse alterations in VSC, however these only make up 3% of the overall 2935 windows assessed.
- 5.4.12. For NSL, 1,351 (90%) of the 1499 rooms would either meet the BRE criteria and experience a negligible effect, or experience a minor adverse effect which is not considered significant. Of the remaining, 35 rooms would experience a moderate adverse effect (significant) and 113 rooms would experience a major adverse effect (significant). Of the 113 rooms experiencing a major adverse effect, 77 rooms are classified as less sensitive bedrooms and non-habitable dressing rooms. A further seven rooms would retain daylight distribution to over 50% of their area which could be considered adequate in an urban context such as this. The remaining 29 rooms experience major adverse alterations in NSL; however, these only make up 2% of the overall 1499 rooms assessed.
- 5.4.13. In the case of Assessment 2 (Masterplan Site and Olympia Way site), the VSC test shows that 2,533 (86%) of the 2,935 windows assessed would either meet the BRE criteria and experience a negligible effect, or experience a minor adverse effect which is not considered significant. 143 windows (5%) would experience a moderate adverse effect (significant) and 259 windows (9%) would experience a major adverse effect (significant).
- 5.4.14. For the NSL test, 1,344 (90%) of the 1,499 rooms assessed would either meet the BRE criteria and experience a negligible effect, or experience a minor adverse effect which is not considered significant. Of the remaining, 39 rooms would experience a moderate adverse effect (significant) and 116 rooms would experience a major adverse effect (significant). Of the 116 rooms experiencing a major adverse effect, 78 rooms are less sensitive bedrooms and non-habitable dressing rooms. A further seven rooms would retain daylight distribution to over 50% of their area which could be considered adequate in an urban context such as this. The remaining 31 rooms would experience major adverse alterations in NSL; however, these only make up 2% of the overall 1499 rooms assessed.
- 5.4.15. A supplemental daylight/sunlight analysis has been produced in support of the proposed development. The report states that some important factors should be considered when considering the effects on sensitive surrounding receptors. In line with the above-mentioned policies, the report reaffirms that the BRE guidelines should be applied flexibly, and the expectations for daylight and sunlight in densely populated urban locations are necessarily lower given the general site layouts and building-to-building relationships attributable to inner city locations. Furthermore, the report states that breaches of BRE numerical guidelines do not necessarily result in unacceptable effects. In this case, several sensitive receptors around the site which already experience unusually low levels of daylight and sunlight for an urban environment, in part due to the historically relatively high-density, nature of the site are highlighted. This is applicable to the

vast majority of neighbouring windows on the lower levels that do not achieve recommended levels in the current context.

- 5.4.16. The report states that the average existing VSC level for ground floor windows is 13% and between 16-17% if the lower three floors windows (lower ground/ground and first floor) is applied. This is in contrast with the 27% VSC recommended in the guidelines. These windows are susceptible to large percentage alterations. The report recommends that a contextual benchmark should be applied as a guide to reflect the environment, as set out in Appendix F of the BRE guidelines and has been applied elsewhere. The application of alternative criteria setting the benchmark at 16% in contrast with the 27% VSC guideline has been applied and would result in an improvement in daylight compliance to between 91-94%.
- 5.4.17. The four properties referred to in paragraph 5.4.10 contain most of the neighbouring windows that would see major adverse percentage alterations. This has been highlighted in the case of 89-119 Hammersmith Road with the proposals for 66 Hammersmith Road. Approximately 35% of the total 'major adverse' losses listed would occur to windows serving 72 Blythe Road. Despite this the majority of the windows are to less sensitive or secondary windows with the majority of primary living spaces still retaining good levels of daylight amenity. Similar situations are highlighted in the cases of 1-50 Palace Mansion, 1-35 Argyll Mansion and 67-81 Hammersmith Road. Rooms experience levels lower than BRE guidelines suggest as a result of the existing nature of the building in question as a direct result of the inherent design features, such as overhanging balconies, recessed windows, etc. As such changes in daylight and sunlight conditions would be unavoidable.
- 5.4.18. The report has also provided a detailed analysis of four comparable schemes in the borough (recently granted or received a resolution to grant permission) with similar levels of VSC compliance. The schemes examined are: The Gateway Site, White City Place, Fulham North Housing Office, Clem Attlee Court, Watermeadow Court, and Fulham Gas Works. The report highlights that the proposed development performs better than the four schemes in relation to the percentage of windows meeting BRE guidelines, windows falling below BRE guidelines and percentage of windows that experience 'major adverse' impacts. The report also set out that 66 Hammersmith Road has received a resolution to grant planning permission since the submission of the application.

Sunlight

- 5.4.19. A total of 1,511 windows were assessed within 76 neighbouring residential properties that were identified as being relevant for the sunlight assessment. For assessing sunlight, the 'Annual Probable Sunlight Hours' (APSH) test which calculates the percentage of access to sunlight from the centre point of the window was applied.
- 5.4.20. In terms of Assessment 1 against the Masterplan Site. 1,383 (92%) of the 1,511 windows assessed would either meet the BRE criteria for winter sunlight and experience a negligible effect, or experience a minor adverse effect which is not considered significant. For total sunlight, 1,438 (95%) of the 1,511 windows

assessed would either meet the BRE criteria and experience a negligible effect or experience a minor adverse effect which is not considered significant.

- 5.4.21. In the case of Assessment 2 (Masterplan Site and Olympia Way site), 1,366 (91%) of the 1,511 windows assessed would either meet the BRE criteria for winter sunlight and experience a negligible effect, or experience a minor adverse effect which is not considered significant. For total sunlight, 1,410 (93%) of the 1,511 windows assessed would either meet the BRE criteria and experience a negligible effect, or experience a minor adverse effect which is not considered significant.
- 5.4.22. The remaining windows considered under Assessments 1 and 2 would experience effects ranging between moderate adverse to major adverse (significant). However, as discussed above in relation to daylight, factors such as existing architectural features e.g. balconies, low existing levels of light, less sensitive room uses e.g. bedrooms and mitigating windows, should also be considered regarding sunlight alterations that fall below the recommended BRE criteria.

Overshadowing

- 5.4.23. A total of 44 public and private amenity areas within proximity of the Olympia Estate were assessed using the 'sun hours on the ground' overshadowing and 'transient overshadowing' methods. The 'sun hours on the ground' overshadowing test calculates the proportion of each amenity area that receives two or more hours of direct sunlight on 21st March. The 'transient overshadowing' test plots the location of shadows for the following three key dates in the year, between the hourly intervals stated: 21st March (Spring Equinox) - 7.00am-7.00pm; 21st June (Summer Solstice) - 5.00am-7.00pm; and 21st December (Winter Solstice) - 7.00am-5.00pm.
- 5.4.24. Most neighbouring amenity areas (41 areas) are not considered to experience significant effects as a result of the proposed development. A moderate adverse effect in terms of the sun hours on ground overshadowing to three amenity areas serving 2-4 Sinclair Road to the north of the site have been identified. In terms of transient overshadowing, no likely significant effects have been identified and the assessment indicates that additional shadow would be experienced during isolated periods of the day and thus the areas would remain unaffected for much of the day.

Daylight/Sunlight Conclusion

- 5.4.25. Officers have considered effects of the proposals on daylight, sunlight, and overshadowing. The policy framework clearly supports the flexible application of daylight, sunlight, and overshadowing guidance to make efficient use of land, and not to inhibit density. These policy documents resist the rigid application of guidelines and signal a clear recognition that there may be circumstances in which the benefits of not meeting them are justifiable, so long as acceptable levels of amenity are still enjoyed. The proposed Development would provide acceptable levels of amenity to existing receptors will continue to enjoy acceptable levels of amenity even where reductions in current levels of daylight or sunlight will take place beyond those recommended by BRE guidelines.

Together with the environmental, social, and economic contribution the proposed development would make through its proposed form, density and layout, the proposal is acceptable in respect of daylight, sunlight, and overshadowing impacts.

5.5 Highways

- 5.5.1. **The NPPF** requires that developments which generate significant movement are located where the need to travel would be minimised, and the use of sustainable transport modes can be maximised; and that development should protect and exploit opportunities for the use of sustainable transport modes for the movement of goods or people. All developments that will generate significant amounts of movement should be required to provide a travel plan, and the application should be supported by a transport statement or transport assessment so that the likely impacts of the proposal can be assessed.
- 5.5.2. **London Plan Policies 6.1, 6.3, 6.10, 6.11 and 6.13** set out the intention to encourage consideration of transport implications as a fundamental element of sustainable transport, supporting development patterns that reduce the need to travel or that locate development with high trip generation in proximity of public transport services. The policies also provide guidance for the establishment of maximum car parking standards.
- 5.5.3. **Local Plan Policy T1** sets out the Council's intention to 'work with strategic partners to improve transport provision, accessibility and air quality in the borough, by improving and increasing the opportunities for cycling and walking, and by improving connections for bus services, underground, national and regional rail'.
- 5.5.4. **Local Plan Policy T2** relates to transport assessments and travel plans and states "All development proposals would be assessed for their contribution to traffic generation and their impact on congestion, particularly on bus routes and on the primary route network".
- 5.5.5. **Local Plan Policies T3, T4, T5 and T7** relate to opportunities for cycling and walking, vehicle parking standards, blue badge holders parking and construction and demolition logistics. Policies 5.16 and 5.17 are relevant to waste and recycling. **Local Plan Policy CC7** sets out the requirements for all new developments to provide suitable facilities for the management of waste. **Planning SPD (2018) Key Principles WM1, WM2, WM7 and WM11** are also applicable which seek off-street servicing for all new developments.

Site Accessibility

- 5.5.6. The application site is located on Hammersmith Road (A315) which is defined as a London Distributor Road in London Borough of Hammersmith and Fulham's Local Plan (2018). The site is enclosed by Olympia Way to the East, Maclise Road to the North and Blythe Road to the West. The application site falls within a location which has a PTAL score ranging from 5 and 6a which is classed as Very Good and Excellent respectively using Transport for London's methodology. Public transport modes currently available include London

Underground, London Overground, and buses, which are within walking distance of the application site.

Trip Generation

- 5.5.7. The methodology used for assessing trip generation for proposed development was agreed with the applicant at pre-planning stage, along with trip rates and mode shares. After further revisions and analysis by the applicant it is considered that the forecasted trip generation is robust and representative of the proposals in a worst-case scenario. Below are the proposed mode shares for various class uses and trip generation for the Masterplan application:

Mode share: B1 (Office), A1 (Non-food retail), A3 (Food and beverage), D1 (Conference Centre), Sui Generis (Theatre), D2 (Cinema) and D2 (Music Venue)

Method of Travel	Total Trips	Modified Trips	Final Percentage
Underground, metro, light rail, tram	38,996	46,029	50%
Train	4,466	5,272	6%
Bus, minibus, or coach	13,802	16,291	18%
Taxi	414	489	1%
Motorcycle, scooter or moped	2,173	0	0%
Driving a car or van	12,002	0	0%
Passenger in a car or van	710	838	1%
Bicycle	7,420	8,758	9%
On foot	12,783	15,089	15%
Total	92,766	92,766	100%

- 5.5.8. The above mode shares for the various class uses were derived from the 2011 census and modified to reflect the proposed uses on the application site. Trips associated with 'driving a car or van' have been reallocated across public transport, walking and cycle modes to reflect the proposed car parking provision. It is considered that the majority of travel mode share will be carried out by public transport and sustainable modes such as cycling and walking.

Mode share: Exhibition Visitors

Method of Travel	Consumer Weekday Mode	Trade Weekday Mode	Consumer Weekend Mode
Underground, metro, light rail, tram	45%	56%	50%
Train	9%	8%	6%

Bus, minibus, or coach	20%	9%	18%
Taxi	2%	4%	1%
Motorcycle, scooter or moped	0%	0	0%
Driving a car or van	5%	6%	21%
Passenger in a car or van	3%	2%	5%
Bicycle	1%	1%	0%
On foot	15%	14%	9%
Total	100%	100%	100%

5.5.9. The above mode shares for exhibition visitors were derived from surveys which were undertaken during March and April 2018.

Mode share: Exhibitors

Method of Travel	Mode Share
Underground, metro, light rail, tram	53%
Train	6%
Bus, minibus, or coach	19%
Taxi	1%
Motorcycle, scooter or moped	0%
Driving a car or van	0%
Passenger in a car or van	1%
Bicycle	0%
On foot	21%
Total	100%

5.5.10. The mode share displayed in the above table represents the proposed mode share of exhibitors travelling to Olympia. The above mode share was derived from a combination of data from Olympia London and site observations.

Total Masterplan Trip Generation

Method of Travel	Weekday				Weekend	
	Network Peaks		Development Peaks		Development Peaks	
	AM Peak (08:00-09:00)	PM Peak (17:00-18:00)	AM Peak (09:00-10:00)	PM Peak (16:00-17:00)	AM Peak (09:00-10:00)	PM Peak (16:00-17:00)

Underground, Metro, Light rail, tram	1308	2262	1051	1359	59	894
Train	160	267	128	162	13	23
Bus, minibus, and coach	482	816	387	493	31	36
Taxi	34	40	26	27	16	22
Motorcycle, scooter or moped	0	0	0	0	0	0
Driving a car or van	14	11	10	9	10	9
Passenger in a car or van	40	54	31	35	13	26
Bicycle	254	435	204	262	15	173
On foot	564	849	445	530	120	377
Total	2857	4735	2283	2876	277	1561

- 5.5.11. The above table represents the forecast trip generation for the proposal. 1308 trips in the AM peak and 2262 trips in the PM peak will be generated on the Underground, Metro, light rail, and tram during the Network peak on a weekday. The trips vary slightly to 1051 for the AM peak and 1359 in the PM peak for the same mode during the development peak. The forecasted trips for the same mode fall to 59 in the AM peak and 894 in the PM peak on a weekend during the Development peak.
- 5.5.12. The following forecasts represent the trips to be carried out combining 'driving a car or van' and 'passenger in a car or van': 54 trips in the AM peak and 65 in the PM peak will be generated during the Network peak and 41 in the AM peak and 44 in the PM peak during the development peak. The trips fall slightly to 23 in the AM peak and 35 in the PM peak during the Development peak over the weekend.
- 5.5.13. Trip generation for cycling is forecast on a weekday to be 254 in the AM peak and 435 in the PM peak during the Network Peak and 204 in the AM peak and 262 in the PM peak during the development peak. The trips fall to 15 in the AM peak and 173 in the PM peak on a weekend during the Development peak.
- 5.5.14. The applicant has not proposed any parking for motorcycles and therefore is not represented in trip generation.
- 5.5.15. In conclusion it is considered that the forecasted trip generation proposes increased travel to and from the application site by walking, cycling and public transport. The proposed trips generated by car will be minimised and managed through a car parking management plan. The promotion of sustainable and active travel to and from the site will be emphasised and encouraged through various travel plans which will be secured via s106 agreement. Further mitigation secured for the upgrades to Kensington Olympia station, West Brompton, London buses, cycle hire docking stations will support the increased uptake in all modes of public transport associated with the proposed development.

Cycling

Long-stay cycle parking

- 5.5.16. The proposal will provide a total of 1019 long-stay cycle parking space, of which 845 will be located at basement level 2. This provision is in accordance with current and draft London Plan standards. New showers, lockers and changing facilities will also be provided for cyclists in close proximity to the three-main long-stay cycle parking areas at basement level 2, in the MSCP and by Olympia Way. Further details of the proposed lifts are sought by condition to determine the suitability regarding the number of proposed users of the basement cycle parking facilities.

Short-stay cycle parking

- 5.5.17. The proposed development will provide a total of 531 short-stay cycle parking spaces for visitors at ground floor level on Olympia Way, Hammersmith Road, and Blythe Road. A further 171 short-stay cycle parking spaces are to be provided with the separate Olympia Way planning application.

Cycle Hire

- 5.5.18. The proposed development is forecast to result in a significant increase in demand for cycle hire in the vicinity of the application site. The applicant has agreed to a financial contribution towards the provision of new or extension of existing cycle hire docking stations in the local area. The financial contribution will be secured via s106 agreement.

CS9

- 5.5.19. The proposals are likely to delay the delivery of CS9 in this part of Hammersmith Road for several years. TfL have therefore requested that the applicant design and fund the delivery of a temporary layout for cyclists. The applicant has submitted initial options for an interim solution, which has been approved in principle by TfL. The temporary solution should form a part of the required Construction Logistics Plan submitted by condition. Payment for the temporary layout and future delivery of CS9 should be secured via legal agreement.

Highway Impact

- 5.5.20. The applicant has submitted updated results from VISSIM modelling which had been undertaken from an existing TfL model to assess the impact of the proposed development on the local highway network. Option 4a, which includes the future baseline, Olympia Masterplan development and the signalisation of Blythe Road, has been put forward as the applicants preferred option. This option would result in D-gate becoming a priority junction which would have to be manned during large scale events to regulate the flow of vehicles and allow pedestrians continued passage on the footway.
- 5.5.21. Option 4a would result in delays of up to 8 minutes for general traffic and buses in the PM peak from Shortland's to Holland Road and up to 2 minutes in the AM peak. The option would also result in delays of up to 4 minutes for general traffic

and buses in the PM peak from Holland Road to Shortland's in the PM peak and up to 3 minutes in the AM peak.

5.5.22. The summary of the applicants preferred option of the updated VISSIM modelling can be seen below, where JT = Journey Time:

AM Peak (07:45 – 08:45) – Shortland's to Holland Road

	Sc1a (TFL)	Sc4a
Traffic JT	00:06:29	00:08:28 (+00:01:59)
Bus JT	00:07:24	00:08:38 (+00:01:14)
Cycle JT	00:05:17	00:12:00 (+00:06:43)

AM Peak (07:45 – 08:45) Holland Road to Shortland's

	Sc1a (TFL)	Sc4a
Traffic JT	00:03:29	00:06:59 (+00:03:30)
Bus JT	00:04:19	00:07:36 (+00:03:18)
Cycle JT	00:04:20	00:05:22 (+00:01:02)

PM Peak (17:45 – 18:45) Shortland's to Holland Road

	Sc1a (TFL)	Sc4a
Traffic JT	00:06:43	00:15:30 (+00:08:47)
Bus JT	00:07:50	00:15:51 (+00:08:08)
Cycle JT	00:04:31	00:04:45 (+00:00:14)

PM Peak (17:45 – 18:45) Holland Road to Shortland's

	Sc1a (TFL)	Sc4a
Traffic JT	00:03:40	00:08:23 (+00:04:44)
Bus JT	00:04:42	00:08:50 (+00:04:08)
Cycle JT	00:06:08	00:07:14 (+00:01:06)

5.5.23. The VISSIM model used by the applicant was obtained from TfL, which was used to aid the design of CS9. TfL are yet to formally audit the updated highway modelling results submitted by the applicant.

Network and Traffic Management

5.5.24. Existing large-scale event days at Olympia have required traffic management being agreed with the council. The development proposal under the outline application involves Olympia Way, which currently forms part of a one-way

system on event days, being closed to all traffic which will lead to all Olympia related traffic and residents to the north of the site accessing the site via Hammersmith Road and Blythe Road.

Car Parking

Multi-Storey Car Park (MSCP)

- 5.5.25. The proposal includes the conversion of the MSCP into a mixed-use building comprising a hotel, cinema, and conference/co-working space. This proposal will lead to the removal of up to 380 car parking spaces which are currently in use at the MSCP and accessed via Maclise Road. Officers are supportive of the removal of all car parking in the MSCP which should lead to a reduction in vehicular movements via Blythe Road and a contribute to a shift in mode share of travel associated with visitors to the application site. Such a reduction and the resultant benefits are strongly supported by and encouraged by policy.

Development parking

- 5.5.26. The proposal features the provision of a new underground car park to be accessed directly from Hammersmith Road, located under the new logistics centre Central Hall. The new car park will have capacity for up to 181 car parking spaces or 82 large vans (Luton Vans). The car park will be utilised by blue badge holders, exhibition visitors and exhibitors only on a pre-booking arrangement and will not be available to members of the public or any other users of the wider Olympia site such as office workers and hotel visitors.
- 5.5.27. It is also proposed to have the entrance to the car park manned by staff on large scale event days to regulate the movements of vehicles leaving the car park and pedestrian flows across the entrance on Hammersmith Road.
- 5.5.28. The existing Motorail car park, which is a pre-existing car park that does not form a part of this planning application, is included in contingency planning which may be used to hold HGVs in the unlikely event of vehicles stacking around the site. The car park may also be utilised by coaches bringing visitors to the site.
- 5.5.29. To satisfy the concerns of officers regarding the future use of the Motorail car park, the applicant has proposed including its management in the site-wide Car Park Management Plan which will be secured within the s106 legal agreement.

On-street parking

- 5.5.30. The applicant has undertaken parking beat surveys for Zones B and BB at the request of officers. It was agreed that the parking beat surveys should be undertaken on a large-scale event day and a non-event day for comparison.
- 5.5.31. The applicant has since submitted results of a parking beat survey conducted on an event day (International Horse Show) for CPZ's B & BB. Results indicate that peak parking demand occurred between 22:00 and 00:00, with 1,070 of a total of 1,450 spaces (74%) occupied. It was also revealed that demand for parking on Maclise Road and Beaconsfield Terrace Road exceeded 100% during the

survey. A parking survey is being undertaken on a non-event day in order to inform the CPZ review secured through the s106 legal agreement.

- 5.5.32. The proposed development is likely to have a significant impact on parking near the application site. The applicant will therefore be required to fund Controlled Parking Zone reviews of parking zones A (east), B, BB, E, and EE and any of the resultant mitigation required which should be secured via s106 agreement.

Public Transport

Kensington Olympia Station

- 5.5.33. The proposals at the application site will have a significant impact on Kensington Olympia station. During peak hours the station currently experiences overcrowding and therefore mitigation is required from the proposed development. Mitigation for Kensington Olympia station has been negotiated in conjunction with TfL officers and secured via s106 agreement.
- 5.5.34. The council is supportive of the aspiration to create step-free access at Kensington Olympia Station. The council prioritises the provision of lifts between platforms over the provision of new gates at the entrance to the station.
- 5.5.35. The council supports the aspiration to re-instate regular District Line services to Kensington Olympia station, however currently TfL oppose such proposals and do not believe the proposed development provides sufficient justification to re-instate the provision.

Buses

- 5.5.36. Analysis of trip generation has highlighted that the proposed development is forecasted to generate significant trips on the bus network. Discussions between the applicant, TfL and officers have resulted in appropriate mitigation being agreed. The financial contribution towards future bus provision should be secured via s106 agreement and is set out in the heads of terms.

Delivery and Servicing (DSP)

- 5.5.37. The outline delivery and servicing plan submitted by the applicant, revolves around the use of the existing booking system Voyage Control. Officers are supportive of the applicant's aspiration to increase compliance of bookings by exhibition related deliveries and their aspirations to increase compliance from 60% to 100%. The applicant has since provided further information which has satisfied officers that in the unlikely occurrence of deliveries arriving to site early or late, as well as access to the logistics centre being unavailable, suitable contingency plans will be in place.
- 5.5.38. The proposed development will deliver a new logistics centre aimed at reducing the negative impacts of delivery vehicles on local roads close to Olympia. The logistics centre has the capacity to keep up to 27 HGVs away from the public highway and increase the efficiency of unloading goods directly to their end destination. The developers' intent is that the new logistics centre will reduce congestion on the roads near the site caused by delivery vehicles, reduce dwell

times of goods vehicles on the site and improve the overall efficiency of delivery and servicing at Olympia.

- 5.5.39. In the event of access to the Logistics Centre being unavailable, Olympia Way would be re-opened to marshal delivery related traffic towards the Motorail car park. If required vehicles may be required to queue on Olympia Way as is required in accordance with the existing traffic management order for large-scale event days.
- 5.5.40. In the event of delivery vehicles arriving on-site outside of their allocated slots, the applicant has proposed to marshal the vehicles through their site towards Hammersmith Road. This proposal is would unnecessarily result in HGVs remaining on the highway network and is opposed by the Highway Authority. The applicant should revise the DSP to include a measure to ensure vehicles that arrive outside of their allocated slot, are not made to leave the site.
- 5.5.41. The Delivery and Servicing strategy has been split into clusters to serve different parts of the development:
- 5.5.42. Cluster 1, the MSCP, will be accessed from Maclise Road and provided with two loading bays. It is forecasted that Cluster 1 will result in a maximum of 26 car/van delivery and servicing trips per day and 2 by HGVs.
- 5.5.43. Cluster 2, Olympia Way, Pillar Hall and National, will be serviced from Olympia way and provided with 12 loading bays. It is estimated that a maximum of 28 car/van trips per day and 5 by HGV's. Olympia Way will only be open for delivery and servicing between 20:00-08:00.
- 5.5.44. Cluster 3, Central, Grand National, G-gate, Level 2 and West, will be serviced from the new logistics centre which has the capacity to park up to 27 HGV's away from the public highway. It is forecasted that the Logistics Centre will generate up to 127 delivery and servicing trips by car/van, which equates to 18 in the peak hour. In addition, the centre will result in up to 10 daily HGV trips, up to 1 in the peak hour.
- 5.5.45. The submitted DSP has included measures and actions aimed at minimising the impacts of freight vehicles and encourage efficient freight operations. Measures include the use of local resources and suppliers, training of staff and occupier awareness. Delivery and servicing targets include setting a maximum number of servicing and deliveries to encourage the consolidation of trips, scheduling delivery and servicing outside of the network peaks and setting a minimum number of deliveries to be undertaken at night (00:00-06:00). These targets will be monitored by servicing surveys and updated within the DSP required to be submitted by way of condition.
- 5.5.46. The applicant should explore the possibility of utilising the nearby national rail line for delivery and servicing purposes. This line is heavily utilised for freight traffic and could lead to a reduction in road traffic associated with deliveries and servicing at Olympia.
- 5.5.47. In conclusion, the proposed delivery and servicing strategy is aimed at reducing congestion on the local highway network caused by delivery vehicles. It is

considered that the DSP proposals, which include the provision a new Logistics Centre capable of unloading up to 27 HGVs away from the public highway, additional loading bays at the MSCP and introduction of an upgraded booking system, will significantly improve delivery and servicing at Olympia subject to effective management.

Construction Logistics Plan (CLP)

- 5.5.48. The applicant has submitted an outline CLP in accordance with Policy T7 the Local Plan. The outline CLP provides information on various aspects of the construction phase of the proposed development.
- 5.5.49. The CLP presents cumulative schemes in the vicinity of the site and seeks to estimate the impact of other large-scale developments within a 1km radius. These developments include Landmark House, Kings Mall Car Park Site, Bechtel House, 66 Hammersmith Road, The Triangle, and many other proposals.
- 5.5.50. It is estimated that the construction of the proposed development will last at least 6 years. The development will be delivered in 4 phases as listed below:
- Phase 1- Q1 Year 1 to Q2 Year 4
 - Phase 2 – Q1 Year 2 to G2 Year 6
 - Phase 3 – Q2 Year 1 to Q1 Year 5
 - Phase 4 – Q1 Year 4 to Q1 Year 6
- 5.5.51. Core working hours during construction in accordance with LBHF guidance are:
- 08:00-18:00 Mon-Fri
 - 08:00-13:00 Sat
 - No working on Sundays or Bank holidays
- 5.5.52. Any variation to the above working hours is only permitted with LBHF approval.
- 5.5.53. Due to the sensitive location of the application site, it is proposed that a 'pit lane' is provided on the north side Hammersmith Road, which would extend onto the footway and approximately 1 metre into the eastbound traffic lane. The pit lane will therefore result in a footway closure and a pedestrian diversion from the western crossing of North End Road junction to the Olympia Way junction, via the southern footway on Hammersmith Road. This provision is required to assist in the controlled movements of HGV's arriving and leaving the site during the construction phase and is subject to final approval.
- 5.5.54. It is anticipated that the majority of construction traffic will access the site approaching from the West of London using the M25, A40 and M4/A4, avoiding Central London. It is proposed that construction vehicles approaching the site will primarily use Hammersmith Road from the A40 or North End Road from the A4. The vehicles would then access the one-way system via Olympia Way. Construction vehicles would egress the site on to Hammersmith road and either head west towards the M25, head east onto North End Road back towards the A4/M25 or east onto Holland Road and back towards to A40/M25. The routing

for construction vehicles has not been agreed by the council and will be considered with the detailed CLP submitted by way of condition.

- 5.5.55. The indicative maximum average of construction vehicles to the site will be 260 (130 in and 130 out) movements per day to be carried out during Q1 to Q2 of year 4. The maximum number of construction vehicle movements in an hour will be 74 (37 in and 37 out). The number of vehicles are derived from an estimate of materials quantities, demolition material and excavated earth based on the current design of the scheme.
- 5.5.56. Further details will be required for traffic management to be included within the detailed submission of the CLP by condition. Further work on the interim solution for CS9 should also be included in the detailed CLP for approval by LBHF and TfL officers. All proposed traffic management associated with the construction phases must be submitted to and approved by the Highway Authority. It is considered that sufficient information has been submitted regarding construction logistics, with a detailed CLP being submitted by condition prior to commencement of construction and updated accordingly as required for each phase of works.

Travel Planning

- 5.5.57. The applicant has submitted a framework travel plan with the masterplan application. Travel plans for all class uses as well as the construction phase will be secured via s106 agreement with monitoring fees for each. An updated travel plan for the exhibition class use is required, taking in to consideration all proposed changes, with monitoring fees also required.

Mitigation and S106 Obligations

- 5.5.58. The following have been requested by Transport for London and are supported by the council's transport officers:

- Gates and associated works at Kensington Olympia Station
- Platform sheltering at Kensington Olympia Station
- London Overground facility improvements
- Advert removal
- Additional sheltering at West Brompton Station
- Upgrade of existing cycle hire docking stations
- Financial contribution towards increased bus capacity
- Temporary and final provision of CS9

- 5.5.59. The proposed development will require the applicant to enter into a section 278 agreement with the council to carry out works to the public highway. The redevelopment of the application site will require the following highway works:

- New vehicular accesses
- Re-instatement of redundant crossovers
- Re-paving of footways immediately surrounding the application site
- Improvement of crossings and links identified in the PERS audit.
- Traffic signals and configuration of junctions

- Reconfiguring of junction of Blythe Road/Lyons Walk
- Reconfiguring of public highway on Hammersmith Road/North End Road
- Public realm improvements to Lyons Walk

5.5.60. Additional highway works which are identified as essential or required as a part of the development will be secured via s106 and s278.

- The applicant is required to dedicate land on Hammersmith Road under s.38/s.72 agreement for highway improvements to remove a narrowing of the highway. (as per the s106 obligation of the previous G-gate development)
- Monitoring fees for Construction Logistics Plan
- Monitoring fees for Travel Plans
- Highway works (as listed under highway works)
- Area wide traffic management review plus financial provision for any consequent mitigation works arising from these reviews.
- CPZ reviews for zones A, B, BB, E & EE plus financial provision for any consequent mitigation works arising from these reviews.

Summary

5.5.61. Subject to the submission of the required documents by condition, the Car Park Management Plan by way of obligation and the mitigation to the impacts of the development required by way of legal agreement, officers consider that the proposed development would be acceptable and in accordance with London Plan Policies 6.1, 6.3, 6.10, 6.11 and 6.13 and Local Plan policies T3, T4, T5, T7 and CC7.

5.6 Energy and Sustainability

5.6.1 **The NPPF** state that development proposals are expected to comply with local requirements and should take account of landform, layout, building orientation, massing and landscaping to minimise energy consumption and to increase the use and supply of renewable and low carbon energy.

5.6.2 **London Plan Policies 5.1, 5.2 and 5.3** require developments to make the fullest contribution to the mitigation of and adaptation to climate change, ensure sustainable design and construction and minimise carbon dioxide emissions. **Policies 5.5, 5.6, 5.7 and 5.8** require developments to provide decentralised energy, renewable energy and innovative energy technologies where appropriate.

5.6.3 **The Mayor's Sustainable Design and Construction SPG** provides guidance on the implementation of London Plan Policy 5.3 and provides a range of additional guidance on matters relating to environmental sustainability.

5.6.4 **Draft London Plan Policy SI2** seeks to extend the extant requirement on residential development to non-residential development to meet zero carbon targets. It maintains the expectation that a minimum reduction of 35% beyond Building Regulations to be met on site (10% or 15% of which should be achieved through energy efficiency for residential development, and non-residential development). Where it is clearly demonstrated that the zero-carbon

target cannot be met on site, the shortfall should be provided through a cash in lieu contribution to the borough's carbon offset fund, or off-site provided an alternative proposal has been identified and delivery is certain.

- 5.6.5 **Draft London Plan Policy SI3** identifies Heat Network Priority Areas, which include the Fulham Gasworks site. Here, major proposals should have a communal heat system in accordance with a hierarchy that priorities connection to local existing or planned heat networks, followed by: use of available local secondary heat sources; generation of clean heat/power from zero-emission sources; and use of fuel cells. CHPs are ranked fifth of the six options, followed by ultra-low NOx gas boilers. Supporting text explains that further information about the relevance of CHP in developments of various scales will also be provided in an Energy Planning Guidance document, which will be kept updated as technology changes, however this guidance has not yet been published. The draft Plan states that it is not expected that gas engine CHP will be able to meet the standards required within areas exceeding air quality limits with the technology that is currently available.
- 5.6.6 **Draft London Plan Policy SI4** seeks to minimise internal heat gain and the impacts of urban heat island effect through design, layout, orientation and materials. An energy strategy should demonstrate how development proposals will reduce potential for overheating and reliance on air conditioning systems in accordance with a hierarchy that prioritises the minimisation of internal heat generation through energy efficient design and reductions to the amount of heat entering a building.
- 5.6.7 **Local Plan Policy CC1** requires major developments to implement energy conservation measures by implementing the London Plan sustainable energy policies and meeting associated CO2 reduction target and demonstrating that a series of measures have been taken to reduce the expected energy demand and CO2 emissions. It requires the use of on-site energy generation to further reduce CO2 emissions where feasible.
- 5.6.8 **Local Plan Policy CC2** seeks to ensure the implementation of sustainable design and construction measures by implementing the London Plan sustainable design and construction policies.

Energy

- 5.6.9 As required, an Energy Assessment has been submitted with the application. No residential units are proposed so in line with the London Plan, the development will be expected to reduce annual CO2 emissions by at least 35% compared to the 2013 Building Regulations baseline and will not need to meet zero carbon standards. The London Plan Energy Hierarchy has been followed in developing an Energy Strategy for the scheme which has prioritised the inclusion of energy efficiency measures and low and zero carbon energy generation on-site.
- 5.6.10 A Building Regulations compliant scheme has been calculated to be responsible for 226.9 tonnes of CO2 a year. The proposed energy efficiency measures which include improved insulation, better airtightness to reduce heat loss, heat recovery on ventilation systems, energy efficient lighting and an efficient space and water heating system which includes a communal heat network and

Combined Heat and Power (CHP) system and renewables in the form of Heat Pumps and PV Panels are calculated to reduce annual CO2 emissions to 171.2 tonnes. This represents a reduction across the site of 36.3%. These improvements do not relate to the works on the Grand Hall, National Hall or Pillar Hall and the Energy Assessment states that no major modifications are proposed for these parts of the proposal. However, where modifications are proposed as part of this redevelopment, there will be energy efficiency improvements such as where plant equipment is replaced or refreshed as part of the building redevelopment

- 5.6.11 Officers consider this approach to be acceptable, although further details on the measures proposed for the Grand Hall, National Hall and Pillar Hall and information on the expected benefits they will provide will only be fully known at later design stages.
- 5.6.12 The development is proposed to include a CHP system. Renewable energy generation is currently proposed in the form of Air Source Heat Pumps and solar PV Panels.
- 5.6.13 In broad terms, the approach is acceptable in energy policy and CO2 reduction terms although there may be scope to revise the approach with regards to on-site energy generation. As such a revised Energy Assessment is considered appropriate prior to the commencement of the relevant works and secured by condition.

Sustainability

- 5.6.14 As required, a Sustainability Statement has been submitted with the application. The Sustainability Statement has used the Mayor of London's SPG on Sustainable Design and Construction - which sets out a number of 'priority' and 'best practice' standards - to guide the design of the development and BREEAM has also been used to target specific levels of sustainability performance. It is noted that the exact 'building use strategy' may be subject variations but the overall targets are for the new build elements of the development to meet the BREEAM "Excellent" rating and for the refurbishment elements to meet the "Very Good" rating. In addition to the carbon reduction measures outlined in the Energy Assessment (see separate comments), other measures that will be designed in include water efficiency, waste management and recycling facilities, use of building materials with low environmental impacts where possible, including recycled materials where feasible, inclusion of measures to minimise noise pollution and air quality impacts, flood risk and sustainable drainage measures (see separate comments), sustainable transport measures and biodiversity improvements. The development site will also be registered with the Considerate Constructors Scheme to encourage environmentally and socially considerate ways of working and reduce adverse impacts arising from the construction process.
- 5.6.15 In broad terms, this approach is welcomed by officers, although there may be specific areas where additional measures to be taken go beyond the BREEAM requirements. Officers therefore consider that it is appropriate to include conditions requiring the implementation of the measures outlined in the Sustainability Statement and require the submission of post construction

BREEAM assessments to demonstrate that the “Very Good” and “Excellent” ratings have been achieved as required.

- 5.6.16 Subject to the inclusion of conditions requiring the implementation of the submitted documents as set out above, requiring submission of Sustainability, BREEAM and Energy Statements, officers therefore consider that the proposed development accords with Policies 5.1, 5.2, 5.3, 5.6, 5.7, 5.8, 5.9, 5.11, 5.12, 5.13, 5.14, 5.15 and 7.19 of the London Plan and Policies CC1, CC2 and CC7 of the Local Plan.

5.7 Flood Risk and Drainage

- 5.7.1 **The NPPF** seeks to meet the challenge of climate change, flooding and coastal change by supporting the transition to a low carbon future in a changing climate taking account of flood risk and coastal change.
- 5.7.2 **London Plan Policies 5.11, 5.12, 5.13, 5.14 and 5.15** require new development to comply with the flood risk assessment and management requirements of national policy, including the incorporation of sustainable urban drainage systems, and specifies a drainage hierarchy for new development. Policy 5.3 identifies the efficient use of natural resources (including water) as a principle for informing the achievement of other policies in the London Plan. Policy 5.11 Part A subsection b recognises the role of green roofs and walls in delivering sustainable urban drainage objectives. Policy 5.13 further states that development should utilise SuDS unless there are practical reasons for not doing so, and should aim to achieve greenfield run-off rates and manage surface water run-off close to source. Policy 5.14 states that planning decisions must ensure that adequate waste water infrastructure capacity is available in tandem with development.
- 5.7.3 **Local Plan Policy CC2** requires major developments to implement sustainable design and construction measures, including making the most efficient use of water.
- 5.7.4 **Local Plan Policy CC3** requires a site-specific Flood Risk Assessment (FRA) for developments in Flood Zones 2 and 3 that: a. addresses the NPPF requirements; b. takes account of the risk of flooding from all relevant sources; c. integrates appropriate flood proofing measures where there is a risk of flooding; and d. provides structural waterproofing measures in subterranean elements and using non-return valves or equivalent to protect against sewer flooding.
- 5.7.5 **Local Plan Policy CC4** (‘Minimising surface water run-off with sustainable drainage systems’) requires all proposals for new development to ‘manage surface water run-off as close to its source as possible and on the surface where practicable, in line with the London Plan drainage hierarchy’. It also requires all major developments to implement SuDS ‘to enable reduction in peak run-off to greenfield run off rates for storms up to the 1 in 100-year event (plus climate change allowance)’ and to provide a sustainable drainage strategy to demonstrate how the strategy will enable these requirements. These are to be retained and maintained for the lifetime of the development, with details of their planned maintenance to be provided.

- 5.7.6 **Draft London Plan Policy SI13** sets out the same requirement and additionally states that proposals for impermeable paving should be refused and that drainage should be design and implemented to address water efficiency, river quality, biodiversity and recreation.
- 5.7.7 The submitted FRA and Drainage Technical Note states that the finished floor level at the multi-storey car park site where more vulnerable uses will be included is set at 3.850m AOD which is well above the level that flood water is expected to reach in the event of a breach of flood defences. This is also the case for the proposed hotel. Flood risks from the River Thames and surface water are low and therefore officers consider that this approach is acceptable.
- 5.7.8 It is clarified that there is a toilet facility proposed in the basement of the multi-storey car park site and it is stated that it is envisaged that all drainage from the basement will need to be pumped prior to connection into the public sewer. With regards to structural water-proofing measures, a Basement Impact Assessment has been submitted as part of the planning application and that the detail design of the water-proofing measures is considered to be appropriately secured by way of condition.
- 5.7.9 Thames Water have raised no objection to the proposal. The Environment Agency do not object to the proposal and comment that the proposed development will result in a 'less vulnerable' use as defined by Table 2 of the Planning Practice Guidance: Flood Risk and Coastal Change within Flood Zone 3a. In line with Table 3, this use class is considered appropriate within Flood Zone 3 providing an adequate Flood Risk Assessment (FRA) is undertaken and demonstrates that the development will not be at an unacceptable risk of flooding and will not increase flood risk elsewhere. Although the application site is located within Flood Zone 3a, it is protected by the Thames Tidal flood defences up to a 1 in 1000 (0.1%) chance in any year flood event. In addition, the EA's most recent breach hazard modelling study (June 2017) shows the site to be outside of the areas impacted by flooding if there was to be a breach in the defences or they were to be overtopped.
- 5.7.10 Subject to the inclusion of conditions requiring the submission of a Surface Water Drainage Strategy and Flood Risk Assessment officers consider that the proposed approach would be acceptable and in accordance with Policies 5.11, 5.13, 5.14 and 5.15 of the London Plan and policy requiring flood risk assessment and development to mitigate flood risk, Policies CC2, CC3, CC4 and CC5 of the Local Plan which requires development to minimise future flood risk.

5.8 Air Quality

- 5.8.1 LBHF was designated as an Air Quality Management Area (AQMA) in 2000 for two pollutants - Nitrogen Dioxide (NO₂) and Particulate Matter (PM₁₀). The main local sources of these pollutants are road traffic and buildings (gas boiler emissions). Paragraph 124 relates to air quality and it states planning decisions should ensure that any new development in air Quality Management Areas is consistent with the local air quality action plan.

- 5.8.2 **London Plan Policy 7.14** seeks that development proposals minimise pollutant emissions and promote sustainable design and construction to reduce emissions from the demolition and construction of the buildings; not worsen existing poor quality air quality. Where additional negative air quality impacts from a new development are identified, mitigation measures will be required to ameliorate these impacts. This approach is consistent with paragraphs 120 and 124 of the NPPF. Further the Mayor of London's Air Quality Strategy provides a framework of policy which aims to improve air quality in London.
- 5.8.3 **The Mayor's Air Quality Strategy (2010)** seek to minimise the emissions of key pollutants and to reduce concentrations to levels at which no, or minimal, effects on human health are likely to occur.
- 5.8.4 **Local Plan Policy CC10** seeks to reduce potential adverse air quality impacts arising from new developments and sets out several requirements.
- 5.8.5 The development site is within the borough wide Air Quality Management Area (AQMA). The cumulative impact of the demolition, construction and operation of the proposed development because of increased vehicle and combustion based energy plant emissions will result in exceedance of the annual mean APEC B (38ug/m³) for NO₂ at existing off-site residential receptors and future on-site B1 and C1 receptors.
- 5.8.6 The Proposed Development will include one central energy centre to be located within the L-Yard. It will contain one 1,944 kW natural gas fired CHP engine and a bank of four 6,515 kW natural gas fired boilers. Additionally, eight 500 kVA and two 1000 kVA emergency diesel generators will be installed.
- 5.8.7 Due to the uplift in floorspace and use of the site there will be an impact with regards to air quality locally, however the overall impact is considered acceptable. Subject to the inclusion of conditions prior to the commencement of above ground works for each phase of the development to address the above mitigation measures, officers consider that the proposed development can accord with Policies 7.14 of the London Plan and Policy CC10 of the Local Plan.

5.9 Contamination

- 5.9.1 **London Plan Policy 5.21** explains that 'the Mayor supports the remediation of contaminated sites and will work with strategic partners to ensure that the development of brownfield land does not result in significant harm to human health or the environment, and to bring contaminated land to beneficial use'. For decision-making, the policy requires 'appropriate measures' to be taken to ensure that development on previously contaminated land does not activate or spread contamination.
- 5.9.2 **Local Plan Policy CC9** requires a site assessment and a report on its findings for developments on or near sites known to be (or where there is reason to believe they may be) contaminated. Development will be refused 'unless practicable and effective measures are to be taken to treat, contain or control any contamination'. Any permission will require that any agreed measures with the council to assess and abate risks to human health or the wider environment are carried out as the first step of the development.

- 5.9.3 **Key principles LC1-6 of the Planning Guidance SPG** identify the key principles informing the processes for engaging with the council on, and assessing, phasing and granting applications for planning permission on contaminated land. The latter principle provides that planning conditions can be used to ensure that development does not commence until conditions have been discharged.
- 5.9.4 Officers have reviewed the submitted Master Plan- Phase 1 Geotechnical and Geo-environmental Desk Study by Pell Frischman. Whilst further detail is required due to potentially contaminative land uses possibly having occurred at, or near to, this site these details can be appropriately and reasonably secured by way of conditions.
- 5.9.5 Subject to the inclusion of conditions requiring the implementation of the submitted documents and submission of further information, officers consider that the proposed development accords with Policies 5.21 and Policy CC9 of the Local Plan given that all identified potentially significant effects during the demolition and construction and the operational stages can be suitably adequately mitigated, such that the significance of the residual effects of the Proposed Development will be negligible and that the land will be suitable for the proposed uses

5.10 Noise

- 5.10.1 **London Plan Policy 7.15** states that development proposals should seek to reduce noise by minimising the existing and potential adverse impacts of noise on, from, within, or in the vicinity of, a development and promoting new technologies and improved practices to reduce noise.
- 5.10.2 **Local Plan Policy CC11** seeks to control the noise and vibration impacts of developments, requiring the location of noise and vibration sensitive development 'in the most appropriate locations'. Design, layout and materials should be used carefully to protect against existing and proposed sources of noise, insulating the building envelope, internal walls floors and ceilings, and protecting external amenity areas. Noise assessments providing details of noise levels on the site are expected 'where necessary'.
- 5.10.3 **Local Plan Policy CC13** seeks to control pollution, including noise, and requires proposed developments to show that there will be 'no undue detriment to the general amenities enjoyed by existing surrounding occupiers of their properties'.
- 5.10.4 Officers consider that the impacts for noise and vibration have been satisfactorily assessed in the submitted Environmental Statement. The proposed limits and mitigation measures are acceptable however specific details will be required to be submitted for each phase of the development. It is therefore considered appropriate to require these details, including insulation and anti-vibration measures for machinery and plant by condition.
- 5.10.5 Subject to the inclusion of conditions requiring the implementation of the submitted documents and submission of further information, officers consider

that the proposed development accords with Policies 7.15 of the London Plan and Policies CC11 and CC13 of the Local Plan.

5.11 Lighting

- 5.11.1 **London Plan Policy 7.5** states that ‘London’s public spaces should be secure, accessible, inclusive, connected, easy to understand and maintain, relate to local context, and incorporate the highest quality design, landscaping, planting, street furniture and surfaces’. Paragraph 7.19 notes that the lighting of the public realm requires ‘careful consideration to ensure places and spaces are appropriately lit, and there is an appropriate balance between issues of safety and security, and reducing light pollution’. Paragraph 7.22 notes that ‘lighting of, and on, buildings should be energy efficient and appropriate for the physical context’. Paragraph 7.62 notes that promotion of nature conservation should be integral to development proposals and, in this context, states that the indirect effects of development (which include lighting) need to be considered alongside direct impacts (such as habitat loss).
- 5.11.2 **Local Plan Policy CC12** seeks to control potential adverse impacts from lighting by requiring all development proposals seeking permission for external lighting to submit details to demonstrate they it would be appropriate for the intended use, provide the minimum amount of light necessary to achieve its purposes, be energy efficient, and provide adequate protection from glare and light spill.
- 5.11.3 **Draft London Plan Policy D7** mirrors the policy and text relating to lighting in the adopted London Plan. Paragraph 3.7.10 further states seeks to ensure that lighting of public realm is appropriate to address safety and security issues and to make night-time activity areas and access routes welcoming and safe, whilst minimising light pollution.
- 5.11.4 The submitted assessment within the Environmental Statement sets out that the majority of the surrounding sensitive receptors would not be significantly affected by light spillage from the proposal with negligible to minor adverse effects. The upper floors of 1-50 Palace Mansions, 1-35 Argyll Mansions, 72 Blythe Road and 67-81 Hammersmith Road may experience a greater degree of impact should lights be left on beyond 11pm. It is considered that this can be mitigated by requiring a reduction of perimeter floor plan lights, automatic blinds and lighting design measures beyond 11pm. The implementation of appropriate measures is secured by way of condition.
- 5.11.5 Subject to the inclusion of a condition requiring details of the required lighting strategy, officers consider that the proposed development accords with Policies 7.5 of the London Plan and Policies CC12 of the Local Plan.

5.12 Wind and Microclimate

- 5.12.1 **London Plan Policy 7.6** states that buildings and structures should not cause unacceptable harm to the amenity of surrounding land and buildings in relation to (inter alia) wind and microclimate. London Plan Policy 7.7 states that tall buildings should not affect their surroundings adversely in terms of microclimate, wind turbulence, overshadowing.

- 5.12.2 **The Mayor's Sustainable Design and Construction SPG** recognises at paragraph 2.3.7 that large buildings can alter their local environments and affect the micro-climate and notes that the Lawson Comfort Criteria can be used to assess the impact of a large building on the comfort of the street environment. It further states that developers should assess the potential impacts at ground level of any building that is significantly taller than its surroundings.
- 5.12.3 **Local Plan Policy DC3** states that tall buildings should not affect their surroundings adversely in terms of microclimate, wind turbulence, overshadowing.
- 5.12.4 **Local Plan Policy CC2** seeks to ensure that developments are comfortable and secure for users and avoid impacts from natural hazards. In supporting text paragraph 13.7 explains that this policy is intended to ensure that developments help to enhance open spaces and contribute to well-being.
- 5.12.4 **Draft London Plan** further addresses wind and microclimate. Indirectly, draft **Policy GG1** requires streets and public spaces to be planned for circulation by the comfort in comfort and safety, and to be welcoming. More directly, draft Policy D8 addresses the environmental impact of tall buildings, requiring careful consideration of the wind (and daylight, sunlight penetration and temperature) conditions around tall buildings and their neighbourhoods so that they do not compromise the comfort and enjoyment of them. Draft paragraph 3.1.2 further states the importance of a comfortable pedestrian environment with regard to levels of sunlight, shade, wind, and shelter from precipitation.
- 5.12.5 The proposed impacts assessed within the Environmental Statement focus upon undesirable wind speeds at ground level, around surrounding buildings and within nearby areas of public space as well as at balcony/terrace level and the railway station.
- 5.12.6 Thoroughfares are considered to have wind conditions that would range from suitable for strolling use to sitting use during the windiest season. Entrances close to West Hall and Hammersmith Road would be suitable for strolling, while entrances elsewhere would be calmer and represent beneficial effects. Amenity spaces during the summer would be acceptable, with L2 being suitable for standing. There would be a negligible effect on the railway station.
- 5.12.7 Possible impacts from wind were identified at West Hall/Blyth Road and on the Central Hall terraces and would require mitigation. It is considered that these impacts can be mitigated through appropriate landscaping which is secured by condition.
- 5.12.8 Subject to the inclusion of conditions requiring the implementation the mitigation measures required, officers consider that the proposed development accords with Policies 7.6 and 7.7 of the London Plan and Policies DC3 and CC2 of the Local Plan in terms of wind and microclimate.

5.13 Ecology and Biodiversity

- 5.13.1 **The NPPF (Paragraphs 168 and 173)** explains that pursuing sustainable development involves (inter alia) 'moving from a net loss of bio-diversity to achieving net gains for the future'. **Paragraph 99** requires new developments to be planned to avoid increased vulnerability to climate change impacts, which include changes to biodiversity. **Paragraph 109** states that the planning system should contribute to 'minimising impacts on biodiversity and providing net gains in biodiversity where possible'. Planning decisions should encourage opportunities to incorporate biodiversity in and around developments and refuse development resulting in harm where this that cannot be adequately mitigated – or as a last resort, compensated.
- 5.13.2 **London Plan Policy 7.19** requires development proposals to make positive contributions to biodiversity (its protection, enhancement, creation and management) wherever possible and to prioritise improving access to nature in arrears deficient in accessible wildlife sites. Policy 7.21 of the London Plan supports the retention of existing trees of value and encourages the provision of additional trees, particularly large-canopied species, in new developments.
- 5.13.3 **Local Plan Policies OS1 and OS5** seeks to enhance biodiversity and green infrastructure in LBHF by (inter alia) maximising the provision of gardens, garden space and soft landscaping, and seeking green and brown roofs and planting as part of new development; seeking retention of existing trees and provision of new trees on development sites; and adding to the greening of streets and the public realm.
- 5.13.4 **Draft London Plan** sets more ambitious targets for ecology and urban greening, which includes a target to increase tree cover in London by 10% by 2050.
- 5.13.5 **Draft London Policy G5** states that major development proposals should 'contribute to the greening of London by including urban greening as a fundamental element of site and building design, and by incorporating measures such as high-quality landscaping (including trees), green roofs, green walls and nature-based sustainable drainage'. Boroughs should develop an Urban Greening Factor (UGF) to identify the appropriate amount of urban greening required in new developments, based on Urban Greening Factors set out in Table 8.2 of the draft Local Plan. Higher standards of greening are expected of predominately residential developments (target score 0.4).
- 5.13.6 **Draft London Policy G7** states that existing trees of quality should be retained wherever possible or replace where necessary. New trees are generally expected in new development, particularly large-canopied species.
- 5.13.7 The existing site has extremely no ecological value, the applicant has appointed an ecologist to provide an early stage assessment of the ecological value of the existing site and high level advice regarding planting strategies and landscaping proposals. No bird or bat roosting was observed and there are no records of invertebrates. The Proposed Development will increase urban greening through a combination of measures such as green or brown roofs, planters and other green infrastructure and an Ecological Management Plan is secured by condition in addition to details to be provided by way of landscaping details and the approval of buildings materials including blue and green roofs.

5.13.8 Subject to the inclusion of conditions officers consider that the proposed development accords with Policies 7.19 and 7.21 of the London Plan and Policies OS1 and OS5 of the Local Plan in terms of ecological and urban greening.

5.14 Security

5.14.1 **The NPPF** seeks to ensure that planning decisions promote public safety and take into account wider security and defence requirements. They should anticipate and address all plausible malicious threats and natural hazards and create safe, inclusive and accessible places that have high levels of amenity and do not undermine quality of life, community cohesion and resilience to due crime and disorder.

5.14.2 **London Plan Policy 7.13** states that through planning decisions development proposals should include measures to design out crime in a manner that is 'in proportion to the risk, deter terrorism, assist in the detection of terrorist activity and help deter its effects'. Policy DC1 seeks to ensure that new developments, new publicly accessible open spaces and new community and leisure facilities are inclusive and accessible, contribute to improving quality of life and reducing the incidence of crime and anti-social behaviour (paragraphs 2.57, 10.5 and 12.3).

5.14.3 Meetings and discussions have taken place between the applicant, the Counter Terrorism Security Advisors and the local police Designing Out Crime Officer/Architectural Liaison Officer. These meetings have also been attended by officers and the Olympia management team. The overall security strategy and design intent has been agreed and accepted in principle and the next stage of the process is to continue dialogue with the applicant and the business, and design and agree the detail of measures to be incorporated within the development. A planning condition regarding secure by design criteria is included.

5.14.4 It is considered that collectively these design measures have been carefully considered in order to reduce the likelihood and fear of crime on the Site and, accordingly, the Proposed Development should be considered acceptable in this respect.

5.14.5 The proposals are considered to be well designed and in accordance with the NPPF, Local Plan, and Policy DC1 of the Local Plan which requires development to reduce the opportunities for criminal behaviour.

5.15 Accessibility

5.15.1 **Local Plan Policy DC1** requires all development to be of a high quality and should have an approach to accessible and inclusive urban design. **Policy D2** requires new buildings to follow the principles of accessible and inclusive design. **Planning SPD Key Principles DA1, DA4, DA5, DA6, DA7, DA8, DA9, DA11, DA12 and DA13** requires all applications to ensure the buildings are designed to be accessible and inclusive to all who may visit or use the building, to remove barriers to all members of the community and how the accessibility will be managed when operational, provide proportion of hotel rooms to be for use

by disabled people, have minimum widths and gradients for accesses, essential lifts, toilets and other required facilities and to engage and consult with disabled people.

- 5.15.2 To the western edge of Olympia Way, the proposal will create a new public realm with ramps and steps that result step free access from this area to the both the Olympia buildings and the proposed Olympia Way proposal under consideration with the new L2 area featuring accessible facilities and a changing places facility. Olympia Way will be landscaped under the associated outline application to provide level, accessible access with blue badge parking and drop off points. Cycling provision throughout the overall development including Olympia Way will feature 5% of spaces for non-standard cycles. Stepped and shallow graded routes are to be incorporated into the landscaping to provide level and low gradient links from Olympia Way to Olympia. Seating locations will be no greater than 50m apart and will feature backrests and arms, materials and street furniture to be secured by condition will provide wayfinding and non-slip surfaces whilst being located off of primary circulation routes. All units will be step free.
- 5.15.3 The exhibition halls will see step free access. Central Hall will have a new floorplate to replace the existing exhibition space that will link through to Grand and National, the new hall has its own access from Hammersmith Road via the new staircase adjoining the theatre and two new lifts. Pillar Hall will have step free access by way of the public realm works to Olympia Way, a new lift will be added. Vertical circulation is greatly improved with lifts cores in the main halls up to the new mezzanine levels and escalators through the current balcony areas.
- 5.15.4 The National and MSCP hotels will have 10% of its rooms accessible and spaced to accord with relevant accessibility regulations, with a proportion also featuring ceiling hoists. The proposed cinema will features wheelchair spaces in a variety of locations and levels as well as amenity seating. Step free terraces are provided at Central Hall at levels 4,6,8,10 and 12. The theatre and music venue buildings will feature accessible back of house and changing facilities for performers, at least 1% of seats to be wheelchair accessible as well as amenity seating together with sanitary facilities. L2 would be accessible by wheelchair from a dedicated lift within Grand Hall adjacent to the new escalator/stair entrance and accessed from the new step free level onto Olympia Way.
- 5.15.3 The council's Disability Forum were engaged by the applicant and officers and were supportive of the proposal and the details to be provided by way of condition. In addition to these an Inclusive Accessibility Management Plan is also included by condition.
- 5.15.4 It is therefore considered that the proposal will provide a high quality environment for disabled and impaired members of the community and the commitments within the Access Statement are positive and deliverable by way of conditions and reserved matters applications. As such the proposal will comply with Local Plan Policies DC1 and DC2 as well as Planning Guidance SPD Key Principles DA1, DA4, DA5, DA6, DA7, DA8, DA9, DA11, DA12 and DA13.

6.0 SECTION 106 HEADS OF TERMS AND CIL

S106 Heads of Terms

- 6.1 **The NPPF** provides guidance for local planning authorities in considering the use of planning obligations. It states that ‘authorities should consider whether otherwise unacceptable development could be made acceptable through the use of conditions or planning obligations and that planning obligations should only be used where it is not possible to address unacceptable impacts through a planning condition’.
- 6.2 **London Plan Policy 8.2** states that: ‘When considering planning applications of strategic importance, the Mayor will take into account, among other issues including economic viability of each development concerned, the existence and content of planning obligations. Development proposals should address strategic as well as local priorities in planning obligations. Affordable housing and other public transport improvements should be given the highest importance’. It goes on to state: ‘Importance should also be given to tackling climate change, learning and skills, health facilities and services, childcare provisions and the provision of small shops.’
- 6.3 **Local Plan Policy INFRA1** (Planning Contributions and Infrastructure Planning) states: ‘The Council will seek planning contributions to ensure the necessary infrastructure to support the Local Plan is delivered using two main mechanisms: ‘Community Infrastructure Levy The Council will charge CIL on developments in accordance with the CIL Regulations (as amended) and the LBHF CIL Charging Schedule. The Council will spend CIL on:
- infrastructure in accordance with the H&F Regulation 123 (R123) List;
 - projects identified for ‘Neighbourhood CIL’; and
 - CIL administration expenses (no more than the statutory cap).
- 6.4 The application Heads of Terms are as follows:
- Affordable work space comprising 5% of the overall eligible Class B1 floorspace of both applications ref. 2018/03100/FUL and 2018/03102/OUT to be provided and estimated to have a value of £30m. should the permitted outline application not come forward then the full floorspace will be provided within the full application.
 - Local procurement amounting to 10% of the total construction cost
 - Local employment, skills and training comprising: 175 apprentices, 2,400 work placements and 222 full-time operational phase workers
 - Each apprentice and work placement attracts a contribution of £3,500 with an estimated value of £10m
 - Non-compliance with the agreed number of apprentices and placements attracts a contribution of £7,000 per apprentice/placement not created
 - Arts fund contribution of £2.5m paid at £250,000 per year indexed for 10 years
 - £10.5m affordable/low cost space contribution
 - A joint committee of LBHF, Yoo and local amenity and resident groups to contribute to the final design and materials of the façade of the theatre
 - Wider community benefits contribution of £2.5m
 - £500,000 to public realm improvement as determined by LBHF

- £2.5m for improvements and management of Lyon's Walk
- £1-£1.2m to acquire Lyon's Walk from LBHF subject to third party valuation
- No business parking permits
- Blue badge parking
- Monitoring fee of £5,000 per year
- Olympia Way public realm improvements including pedestrian/cyclist conflict resolution, accessibility improvements, hard and soft landscaping and wayfinding
- Travel Plans for each land use to be monitored at years 1, 3 and 5 at a monitoring fee of £5,000 per submission
- Travel Plan for the construction period with a monitoring fee of £5,000 per year of construction
- The applicant is required to dedicate land on Hammersmith Road under s.38/s.72 legal agreement for highway improvements to remove a narrowing of the highway.
- Car Park Management Plan also including Motorail Car Park
- Area wide traffic management review plus financial provision for any consequent mitigation works arising from these reviews.
- CPZ reviews for zones A, B, BB, E & EE at £30,000 per zone plus financial provision for any consequent mitigation works arising from these reviews.
- Highway works by s278 agreement including but not limited to:
 - New vehicular accesses
 - Re-instatement of redundant crossovers
 - Re-paving of footways immediately surrounding the application site
 - Improvement of crossings and links identified in the PERS audit.
 - Traffic signals and configuration of junctions
 - Reconfiguring of junction of Blythe Road/Lyons Walk
 - Reconfiguring of public highway on Hammersmith Road/North End Road

6.5 In addition to the above, the applicant has agreed to enter into the following Heads of Terms as wider community benefits:

- Free tickets to borough community and community groups for theatres and live events: tickets over 10 years to a value of £600,000
- Use of theatre space and back office rooms to local groups for free
- Priority tickets to cinema and theatre to disabled residents
- Future occupiers to engage with local schools and colleges to provide training opportunities
- Theatre and community space occupier to engage with local groups, schools and colleges
- LBHF partnership with Yoo and occupier foundations to deliver council programmes
- Future performing arts groups to undertake educational outreach, internship and other programs

6.6 The following have been requested by Transport for London and will be covered within the s106, the financial contributions are currently estimated and will be confirmed by way of feasibility modelling:

- Gates and associated works at Kensington Olympia Station, estimated contribution of £1.35m
- Platform sheltering at Kensington Olympia Station, estimated contribution of £350,000
- London Overground facility improvements, estimated contribution of £180,000
- Advert removal
- Additional sheltering at West Brompton Station, estimated contribution of £100,000
- Total estimated allowance for station mitigation: £2.5m
- Upgrade of existing cycle hire docking stations contribution of £200,000
- Financial contribution of £1.8m towards increased bus capacity
- Temporary and final provision of CS9

Local and Mayoral CIL

6.7 This development would be subject to a London wide community infrastructure levy. The Mayor's CIL (Community Infrastructure Levy) came into effect in April 2012. This would contribute towards the funding of Crossrail. The GLA expect the Council, as the Collecting Authority, to secure the levy in accordance with London Plan Policy 8.3 and is chargeable in this case at £50 per sq.m uplift in floor space (GIA).

7.0 CONCLUSION

7.1 In considering planning applications, the Local Planning Authority needs to consider the development plan as a whole and planning applications that accord with the development plan should be approved without delay, unless material considerations indicate otherwise and any adverse impacts of doing so would significantly and demonstrably outweigh the benefits

7.2 In the assessment of the application regard has been given to the NPPF, London Plan, and Local Plan policies as well as guidance. It is considered that the proposal is acceptable in land use and design terms. The quantum of the proposed land uses and the resulting nature of the site does not give rise to any unacceptable impacts and will amount to sustainable development in accordance with the National Planning Policy Framework.

7.3 The redevelopment of Olympia to provide a mixed use cultural, employment and visitor attraction that will support the ongoing use of Olympia site as a pre-eminent exhibition centre within London and beyond is very much in compliance with the overarching objective of development plan policies to support the continued success of such sites, to provide the range of visitor, leisure, employment and cultural uses proposed and its contribution to the local and wider London economy. It is however acknowledged that there will be some impacts as a result of the proposal.

- 7.4 The delivery of the proposals would support the vitality of the exhibition centre business and related hospitality facilities. Officers are of the view that the proposals would support the long-term sustainability and viability of the exhibition centre business and hospitality facilities which are vital for the long-term conservation of the most significant heritage assets on the site – the Grade II* listed Grand Hall and Grade II* listed Pillar Hall. The approval of a masterplan also reduces the potential for successive harmful piecemeal alterations and extensions to the designated heritage assets in the future. The implementation of the masterplan and the phasing of the development including the delivery of heritage benefits that would enhance the significance of heritage assets on the site, would be secured by conditions and a legal agreement.
- 7.5 Before turning to the overall planning balance a conclusion on the heritage impacts must be reached. Considerable weight must be given to the preservation of the settings of listed buildings and conservation areas as set out in statute and the NPPF. Decision makers must acknowledge any harm arising and then attach considerable weight to it and then only, assess whether there are circumstances that outweigh the harm identified to allow permission to be granted. There is a statutory presumption in favour of refusal if harm is present.
- 7.6 The proposal would cause substantial harm to the significance of the Grade II listed Multi-Storey Car Park, due to the demolition proposed. However, it should be noted that:
- The existing use of the Multi-Storey Car Park is unsustainable in environmental terms and is not compatible with the need to provide a world class exhibition centre and associated public realm on the site, in order to ensure the long term sustainability of the exhibition centre business and therefore the original use of the exhibition halls.
 - The MSCP was specifically designed to be used as a car park and was built to the standards of the 1930s.
 - As such, finding a viable reuse of the building would be very difficult due to the plan form, split level car parking decks and poor thermal efficiency.
 - It is likely that the alterations necessary to facilitate any viable reuse of the building would result in substantial harm to the significance of the listed building and as such the substantial harm identified is unavoidable.
- 7.7 The proposal also results in less than substantial harm to the Grade II Grand Hall and Pillar Hall and the Grade II National Hall and Central Hall. In addition less than substantial harm is identified to the Olympia and Avonmore Conservation Area, the Lakeside/Sinclair/Blythe Road Conservation Area, and Dorcas Estate Conservation Area. It will cause minor harm to Grade II listed Blythe House, the Brook Green Conservation Area and the Fitzgeorge and Fitzjames Conservation Area. It will also cause less than substantial harm to the significance of the Holland Park Conservation Area and Edwardes Square/Scarsdale Conservation Area in the Royal Borough of Kensington and Chelsea.
- 7.8 The proposal would deliver a number of substantial design and heritage benefits that must be taken into account:

Design Benefits

- The new additions to the site represent a high quality of design which will continue the evolution of the Olympia Estate with bold and distinctive buildings which have their own character and contribute to the legibility of the exhibition centre venue as a landmark.
- The proposals would deliver greater permeability through the Olympia Estate, opening up it to the public and would provide a greater extent of active frontages to the surrounding streetscene that would animate some of the dead frontages of the buildings on the site.
- The proposals would deliver public realm improvements to Olympia Way and new public realm at Level 2 along the skydeck and Central Avenue.
- The proposals will deliver accessibility improvements to the existing buildings on the site.
- These works will allow the public to better appreciate the significance of the heritage assets on the site.

Heritage Benefits

- The proposals would result in the sustainable reuse of underutilised listed buildings on the site such as Pillar Hall and the redevelopment of the vacant G-Gate site, which currently detracts from the character and appearance of the Conservation Area.
- The proposals are considered to represent the optimum use of the Grand Hall, Pillar Hall, the exhibition hall at National Hall and Olympia Central.
- The proposals would provide a workable, long term future for the five designated heritage assets on the site, which would be managed as one estate.
- The delivery of the proposals would support the vitality of the exhibition centre business and related hospitality facilities, the long term sustainability of which are vital for the long term conservation of the most significant heritage assets on the site – the Grade II* listed Grand Hall and Grade II* listed Pillar Hall.
- The approval of a masterplan also reduces the potential for successive harmful piecemeal alterations and extensions to the designated heritage assets in the future.
- The implementation of the masterplan and the phasing of the development including the delivery of heritage benefits that would enhance the significance of heritage assets on the site, would be secured by conditions and a legal agreement.
- The proposals would result in the removal of rooftop plant which creates visual clutter between the listed buildings.
- The removal of the brick infill between Grand Hall and National Hall which would better reveal the significance of these two development phases on the Olympia Estate and allow the reinstatement of part of the flank elevation of the Grand Hall enhancing its significance.
- The removal of the single storey buildings in front of Grand Hall which would better reveal the significance of the Grand Hall, allow for the restoration of its front elevation, enhancing its significance and improving the character and appearance of the Conservation Area.

- The reinstatement of the original entrance to National Hall would enhance the significance of the listed building and improve the character and appearance of the Conservation Area.
- The proposals also include the restoration of some important original architectural features to the listed buildings which have been damaged or lost over the decades including the bas relief within the Triumphal Arch on the front elevation of Grand Hall, the sculpture of Britannia on the front elevation of Grand Hall and the '1929' relief on the front elevation of Olympia Central. These would enhance the significance of the listed buildings.
- More generally, works are proposed to repair and clean the elevations of the listed buildings on the site.
- The public realm improvements to Olympia Way would improve the setting of the Grand Hall and Pillar Hall and the character and appearance of the Conservation Area.

7.9 The proposal would deliver substantial public benefits which are considered to outweigh the harm identified in the Officer Report. The benefits include:

- The redevelopment of Olympia would deliver a mixed use cultural, employment and visitor attraction, providing economic, cultural, and social benefits
- The proposal will be supportive of and complementary to the continued success of London's diverse range of arts, cultural, professional sporting and entertainment enterprises and their associated cultural, social, and economic benefits.
- The development would contribute sustainably to the local and wider London economy
- As part of the overall masterplan approach, the scheme would provide significant employment opportunities both in the borough and London generally. The development would generate an estimated 565 construction related full time equivalent (FTE) jobs per year over the build period and some 4,560-5,045 further FTE jobs once the development is complete and operational
- Affordable workspace to be provided at low cost to facilitate small and medium sized companies, contributing to the local, borough and London economy
- Local procurement arising from the development is estimated at £80m, providing local companies with the opportunity for significant contracts
- The development would provide modern and upgraded floorspace, and deliver wider benefits by way of increasing local expenditure through increased employment levels, additional visitors through the visit, cultural and leisure uses proposed, and job and job opportunities for residents and companies.
- The removal of buildings to Olympia Way will allow Olympia to create a high quality accessible pedestrian and cyclist friendly public realm, delivering healthy streets and will contribute to the overall realignment of logistics and vehicular transport to the Olympia site
- Employment and training initiatives secured through the S106 agreement would bring significant benefits to the local community while a local procurement initiative will be entered into by way of the legal agreement to provide support for businesses.

- An Arts Fund of £2.5m will be created with substantial benefits to the creative, cultural and artistic economy of the borough and providing these benefits to the local community
- Delivers an opportunity for significant enhancement and regeneration of the area
- Local highway improvements such as Lyons Walk will improve the public realm and the environment for the local community
- The resulting upgrades and refurbishment to Kensington Olympia and West Brompton Station will benefit all passengers using these stations
- Free tickets to borough community and community groups for theatres and live events: tickets over 10 years to a value of £600,000
- Use of theatre space and back office rooms to local groups for free
- Priority tickets to cinema and theatre to disabled residents
- Future occupiers to engage with local schools and colleges to provide training opportunities
- Theatre and community space occupier to engage with local groups, schools and colleges
- LBHF partnership with Yoo and occupier foundations to deliver council programmes
- Future performing arts groups to undertake educational outreach, internship and other programs

7.10 The proposed development has demonstrable substantial design, heritage and public benefits which constitute material considerations that are considered to outweigh the harm identified and add weight to the case for granting planning permission.

7.11 A high quality development is proposed and the principle of a re-developed Olympia as set out is in accordance with the development plan when taken as a whole. It delivers substantial design, heritage and public benefits that are considered to outweigh the harm to designated heritage assets. Officers have taken account of all the representations received and in overall conclusion for the reasons detailed in this report, it is considered having regard to the development plan as a whole and all other material considerations that planning permission should be granted.

7.12 Accordingly it is recommended that the proposal be granted subject to the conditions listed, the completion of s106 and no contrary direction from the Mayor of London.

Appendix 1: Consultation Comments

Greater London Authority	16/01/2019
Historic England	05/11/2018
Thames Water	15/11/2018
Natural England	06/11/2018
Transport for London	15/11/2018
TFL Underground Infrastructure Protection	21/11/2018
RBKC	04/12/2018
RBKC	28/12/2018
GLAAS	10/12/2018

Appendix 2: Neighbour Comments

40 Sterndale Road	23/10/2018
3 Ceylon Road	23/10/2018
26 Applegarth Road	25/10/2018
122C Edith Road, West Kensington	26/10/2018
40 Minford Gardens	26/10/2018
1 Glyn Mansions, Hammersmith Road	27/10/2018
Flat 3, 115 Sinclair Road	27/10/2018
106B Sinclair Road	29/10/2018
Sinclair Road	29/10/2018
14 North End Road	30/10/2018
8 Avonmore Road	02/11/2018
4 Oxfield Lane, Brook Green	05/11/2018
Flat 3, Alexandra House, Sulgrave Road	05/11/2018
30 Dewhurst Road	05/11/2018
Flat 3, Alexandra House, Sulgrave Road	06/11/2018
19C Sinclair Road	06/11/2018
16 Ceylon Road	08/11/2018
13 Sinclair Road	08/11/2018
28 Vernon Street	09/11/2018
5 Southcombe Street	10/11/2018
Flat 6, 2 Sinclair Road	10/11/2018
LAMDA, 155 Talgarth Road	12/11/2018
18 Vernon Street, West Kensington	14/11/2018
Theatres Trust	16/11/2018
NAG	16/11/2018
36A Gratton Road	17/11/2018
Flat 1, 50 Sinclair Road	17/11/2018
Flat 47, Palace Mansions, Earnsley Street	17/11/2018
32 Mattheson Road	18/11/2018

66 Overstone Road	19/11/2018
69 Edith Road	19/11/2018
2 Beaconsfield Terrace Road	20/11/2018
36 Blythe Road	20/11/2018
46 Blythe Road	20/11/2018
46 Blythe Road	20/11/2018
46 Blythe Road	20/11/2018
5A Applegarth Road	20/11/2018
74 Blythe Road	20/11/2018
Blythe Road	20/11/2018
The Jameson, 43 Blythe Road	20/11/2018
113 Milson Road	20/11/2018
41A Maclise Road	20/11/2018
5 Ceylon Road	20/11/2018
70 Sterndale Road	20/11/2018
Granary Cottage Ashurst, NR Steyning	21/11/2018
31 Argyll Mansion, Hammersmith Road	21/11/2018
3 Russell Road	22/11/2018
81 Sterndale Road	22/11/2018
33 Hofland Road	22/11/2018
16 Redan Street	23/11/2018
22 Maclise Road	23/11/2018
34 Ceylon Road	24/11/2018
Unit 4, 48 Addison Gardens	25/11/2018
26 Appelgarth Road	25/11/2018
The Avenue Leasholders Association (Fitzgeorge and Fitzjames Avenue Estates)	26/11/2018
32 Hofland Road	26/11/2018
36 Riverview Gardens	26/11/2018
11 North End Parade	27/11/2018
11 Thackeray Court	27/11/2018
12 Calcott Court, Blythe Road	27/11/2018
13-15 North End Parade, North End Road	27/11/2018
137 North End Road	27/11/2018
14 Calcott Court	27/11/2018
17 Calcott Court	27/11/2018
19 Ladbrooke Gardens	27/11/2018
20 Elgar Court Blythe Road	27/11/2018
22 North End Parade	27/11/2018
27 Northern Parrade, West Kensington	27/11/2018
3 Irving Road	27/11/2018
450A Uxbridge Road	27/11/2018
5 Calcott Court	27/11/2018
7 North End Road	27/11/2018
87 Hammersmith Road	27/11/2018
95 Hammersmith Road, Carnival Store Limited	27/11/2018
Flat 11, Todber House, 60 Russell Road	27/11/2018

Flat 12, Clacott Court, Blythe Road	27/11/2018
Wassouf Lounge, 4-5 North End Parade	27/11/2018
13 Fielding Road	27/11/2018
40 Minford Gardens	27/11/2018
Basement Flat, 21 Sinclari Road	27/11/2018
Basement Flat, 21 Sinclari Road	27/11/2018
35 Thackeray Court, Blythe Road	27/11/2018
35A Gratton Road	27/11/2018
Deepings Gun Lake, Knebworth	28/11/2018
80 Richmond Way	28/11/2018
83 Sinclair Road	28/11/2018
Flat 1, 11 Sinclair Gardens	28/11/2018
4 Seaview Road, Newhaven	28/11/2018
Flat 3, Kingsley House, Avonmore Place, West Kensington	29/11/2018
Top Flat, 16 Maclise Road	29/11/2018
2 Sterndale Road	29/11/2018
Flat 3, 7 Fielding Road	29/11/2018
11 Glenallan House, North End Crescent	30/11/2018
14 Ben Jones	30/11/2018
19 The Grange Lisgar Terrace	30/11/2018
2 Burn Jones House	30/11/2018
20 The Grande Lisgar Terrace	30/11/2018
23 The Grange London	30/11/2018
28 The Grande London	30/11/2018
38 Burne Jones House	30/11/2018
39 Burne Jones House	30/11/2018
47 Burne Jones House	30/11/2018
58 Burne Jones House	30/11/2018
70 Burne Jones House	30/11/2018
87 Bonjour	30/11/2018
Flat 25, Burne Jones House	30/11/2018
56A Sinclair Road	30/11/2018
57 Faroe Road	30/11/2018
69 Masbro Road	30/11/2018
14 Brook Green	01/12/2018
14 Ceylon Road, 45 Holland Park	01/12/2018
31 Hofland Road	01/12/2018
Flat 6, 35-37 Gratton Road	01/12/2018
102 Roseford Court	02/12/2018
102 Roseford Court	02/12/2018
110 Roseford Court	02/12/2018
12 Shepherds Court	02/12/2018
14 Roseford Court	02/12/2018
14 Woodford Court	02/12/2018
16 Roseford Court	02/12/2018
17 Woodford Court	02/12/2018

31 Woodford Court	02/12/2018
32 Woodford Court	02/12/2018
40 Roseford Court	02/12/2018
41 Shepherds Court	02/12/2018
43B Fairholme	02/12/2018
57 Roseford Court	02/12/2018
59 Shepherds Court	02/12/2018
70 Woodford Court	02/12/2018
79 Shepherds Court, Shepherds Bush Green	02/12/2018
83 Roseford Court	02/12/2018
83 Shepherds Court	02/12/2018
86 Roseford Court	02/12/2018
88 Shepherds Court	02/12/2018
90 Roseford Court	02/12/2018
95 Roseford Court	02/12/2018
99 Shepherds Court	02/12/2018
Flat 76, Latymer Court, Hammersmith Road	02/12/2018
47 Woodford Court	02/12/2018
48 Caithness Road	02/12/2018
13 Ceylon Road	02/12/2018
13 Hide Road	02/12/2018
14 Ceylon Road	02/12/2018
23 Fitzgeorge Avenue	02/12/2018
5 Larner Court, Heathstan Road	02/12/2018
56A Sinclair Road	02/12/2018
70 Sinclair Road	02/12/2018
17 Sinclair Road	03/12/2018
30 Glynn Mansions, Hammersmith Road	03/12/2018
46 Fitzgeorge Avenue	03/12/2018
47 Melrose Gardens	03/12/2018
47 Melrose Gardens	03/12/2018
53 Tasso Road	03/12/2018
59 Sterndale Road	03/12/2018
8 Rayburn Court, Milson Road	03/12/2018
Chicken Shed	03/12/2018
Flat 3, 202 Stephendale Road	03/12/2018
Basement, 84 Sinclair Road	03/12/2018
8 Rayburn Court Milson Road	03/12/2018
Esskay Management Services, 24 Parsons Green Lane	03/12/2018
20A Argyll Mansions	04/12/2018
43 Caithness Road	04/12/2018
20A Argyll Mansions	04/12/2018
4 Cloncurry Street	05/12/2018
15 Avonmore Road	05/12/2018
1 Glyn Mansions, Hammersmith Road	05/12/2018
12 Richford Street	05/12/2018

NAG	05/12/2018
Flat 3, 202 Stephendale Road	05/12/2018
22 Anley Road	06/12/2018
Second Floor, 6A Maclise Road	07/12/2018
NAG	07/12/2018
Flat 9, Spencer Mansions, Queens Club Gardens	07/12/2018
83 Archel Road	07/12/2018
55 Tasso Road	07/12/2018
31 The Park, Ealing	07/12/2018
3 Samuel Richardson House	07/12/2018
23A Sinclair Road	07/12/2018
21 Merlin Court	07/12/2018
21 Madeline Court	07/12/2018
16A Perham Road	07/12/2018
16 Samuel Richardson House	07/12/2018
10 Ash Court, 29 Forest View	07/12/2018
50 Bolingbroke Road	07/12/2018
48 Phillimore Gardens	07/12/2018
Flat 23 Autumn Court	08/12/2018
32 Ellaline Road	08/12/2018
30 Aynhoe Road	08/12/2018
2 Autumn Court, Lisgar Terrace	08/12/2018
Flat 3, 23 Sinclair Road	08/12/2018
9 Walpole Court	09/12/2018
8 Avonmore Road	09/12/2018
Ground Floor Flat, 29 Sinclair Road	09/12/2018
14 Coleridge Court	09/12/2018
Flat 12, Chelsea Wharf	10/12/2018
Flat 6, Cleridge Court, Blythe Road	10/12/2018
NAG	10/12/2018
62 Barons Court Road	10/12/2018
62 Barons Court Road	10/12/2018
56 Brook Green	10/12/2018
55 Sinclair Road	10/12/2018
NAG	10/12/2018
Quadrant Estates (33 Great Portland Street)	10/12/2018
Historic Buildings Group	10/12/2018
Sinclair Residents Association	10/12/2018
London Wine Fair	11/12/2018
26 Argyll Mansions, Hammersmith Road	11/12/2018
24 Ablemarle Street	11/12/2018
17 Avonmore Gardens	11/12/2018
NAG	11/12/2018
61 Masbro Road	11/12/2018
F2F Events, Tythe Barn, High Street, Edlesborough	11/12/2018
49 Lily Close West Kensington	12/12/2018

45 Lily Close, West Kensington	12/12/2018
Olympia Beauty, 1E The Courtyard, Westerham	12/12/2018
NAG	13/12/2018
NAG	13/12/2018
73 Milson Road	13/12/2018
15 Dunsany	13/12/2018
Montgomery	13/12/2018
Avonmore Residents Association	14/12/2018
28 Phoenix Lodge Mansions, Brook Green	14/12/2018
71 Milson Road	14/12/2018
71 Milson Road	14/12/2018
31 Rowan Road	14/12/2018
30A Gratton Road	14/12/2018
104 Sinclair Road	14/12/2018
Flat 1b, 1 Russell Road	14/12/2018
41 Sinclair Road	15/12/2018
74 Masbro Road	17/12/2018
Fresh Montgomery	17/12/2018
Sinclair Road Residents Association	17/12/2018
5 Kensington West, Blyth Road	17/12/2018
82 Bishops Mansions, Bishops Park Road	19/12/2018
Flat 84 Kensington West, Blythe Road	20/12/2018
NAG	20/12/2018
AEO (119 High Street, Berkhamsted)	21/12/2018
71 Addison Road	21/12/2018
30 Glyn Mansions, Earsby Street	21/12/2018
20 More Close	23/12/2018
Mackbrooks (Romeland Hill, St Albans)	27/12/2018
Centaur Media	27/12/2018
18 Maclise Road	27/12/2018
51 Kensington West, Blythe Road	27/12/2018
17 Oakford House, 72 Russel Road	02/01/2019
Hammersmith Society	04/01/2019
94 Bush Court	04/01/2019
88 Roseford Court	04/01/2019
88 Bush Court	04/01/2019
6 Bush Court	04/01/2019
39 Roseford Court, Shepherds Bush Green	04/01/2019
34 Rosecroft Court	04/01/2019
17 Roseford Court	04/01/2019
83 Rosecroft Court	04/01/2019
Hallmark Estates	05/01/2019
Designated Contractors Ltd 46 Great Marlborough St	05/01/2019
82 Faroe Road	08/01/2019
Flat 1, 32 Manchester	08/01/2019
11 Boswell Court, Blythe Road	09/01/2019

11 Thackeray Court, Blythe Road	09/01/2019
13 Calcott court, Blythe Road	09/01/2019
14 Calcott Court	09/01/2019
15 Boswell Court	09/01/2019
16 Thackeray Court	09/01/2019
20 Broadwood Terrace, Warrick Road Estate	09/01/2019
20 Elgar Court	09/01/2019
5 Thackeray Court	09/01/2019
8 Boswell Court	09/01/2019
Bronte Court, Girdles Road	09/01/2019
Flat 14, Eldar Court	09/01/2019
Contemporary Design Solutions, 46 Marlborough St	10/01/2019
UBM EMEA 240 Blackfriars Road	10/01/2019
77 Churchward House	17/01/2019
7 Gibbs Green	17/01/2019
65 Fairburn House	17/01/2019
65 Churchward House	17/01/2019
41 Churchward House	17/01/2019
4 Churchwood house	17/01/2019
33 Churchward House	17/01/2019
27 Fairburn House	17/01/2019
26 Churchward House	17/01/2019
2 Fairburn House	17/01/2019
133 Gibbs Green	17/01/2019
120 Gibbs Green	18/01/2019
113 Gibbs Green	19/01/2019
113 Gibbs Green	20/01/2019
11 Churchward House	21/01/2019
29 Gibbs Green	22/01/2019
53 Fairburn House	23/01/2019